

# Flanges and their joints — Circular flanges for pipes, valves, fittings and accessories, PN designated —

## Part 1: Steel flanges

The European Standard EN 1092-1:2007 has the status of a British Standard

ICS 25.040.60

## National foreword

This British Standard is the UK implementation of EN 1092-1:2007. It supersedes BS EN 1092-1:2002 which is withdrawn.

The UK participation in its preparation was entrusted to Technical Committee PSE/15, Flanges.

In BS EN 1092-1:2007, the materials and material groups used in the manufacture of flanges are given in Table 9 and their corresponding Pressure/Temperature ratings are given in Annex G (normative). Additional materials that are widely in used in Europe are listed in Annex D (informative) but BS EN 1092-1:2007 contains no corresponding Pressure/Temperature information for these materials. National Annex NA (informative) contains guidance on Pressure/Temperature ratings for materials S235JR/1.0038 and ASME SA 105, which are predominantly used in the UK.

A list of organizations represented on this committee can be obtained on request to its secretary.

This publication does not purport to include all the necessary provisions of a contract. Users are responsible for its correct application.

**Compliance with a British Standard cannot confer immunity from legal obligations.**

This British Standard was published under the authority of the Standards Policy and Strategy Committee on 31 October 2007

### Amendments issued since publication

Amd. No.	Date	Comments

© BSI 2007

ISBN 978 0 580 55313 4

English Version

**Flanges and their joints - Circular flanges for pipes, valves, fittings and accessories, PN designated - Part 1: Steel flanges**

Brides et leurs assemblages - Brides circulaires pour tubes, appareils de robinetterie, raccords et accessoires, désignées PN - Partie 1: Brides en acier

Flansche und ihre Verbindungen - Runde Flansche für Rohre, Armaturen, Formstücke und Zubehörteile, nach PN bezeichnet - Teil 1: Stahlflansche

This European Standard was approved by CEN on 23 June 2007.

CEN members are bound to comply with the CEN/CENELEC Internal Regulations which stipulate the conditions for giving this European Standard the status of a national standard without any alteration. Up-to-date lists and bibliographical references concerning such national standards may be obtained on application to the CEN Management Centre or to any CEN member.

This European Standard exists in three official versions (English, French, German). A version in any other language made by translation under the responsibility of a CEN member into its own language and notified to the CEN Management Centre has the same status as the official versions.

CEN members are the national standards bodies of Austria, Belgium, Bulgaria, Cyprus, Czech Republic, Denmark, Estonia, Finland, France, Germany, Greece, Hungary, Iceland, Ireland, Italy, Latvia, Lithuania, Luxembourg, Malta, Netherlands, Norway, Poland, Portugal, Romania, Slovakia, Slovenia, Spain, Sweden, Switzerland and United Kingdom.



EUROPEAN COMMITTEE FOR STANDARDIZATION  
COMITÉ EUROPÉEN DE NORMALISATION  
EUROPÄISCHES KOMITEE FÜR NORMUNG

Management Centre: rue de Stassart, 36 B-1050 Brussels

## Contents

Page

Foreword.....	4
Introduction.....	5
<b>1</b> Scope.....	<b>6</b>
<b>2</b> Normative references.....	<b>6</b>
<b>3</b> Terms and definitions.....	<b>8</b>
<b>4</b> Designation.....	<b>9</b>
4.1 General.....	9
4.2 Standard designation.....	9
<b>5</b> General requirements.....	<b>10</b>
5.1 Materials.....	10
5.1.1 General.....	10
5.1.2 Methods of manufacture related to base material.....	10
5.2 Repairs by welding.....	11
5.3 Bolting.....	11
5.4 Gaskets.....	11
5.5 Determination of p/t ratings.....	11
5.6 Dimensions.....	12
5.6.1 Flanges and collars.....	12
5.6.2 Hubs.....	12
5.6.3 Threaded flanges.....	13
5.6.4 Bolt holes.....	13
5.6.5 Lapped joints.....	13
5.6.6 Collar types.....	13
5.7 Facings.....	13
5.7.1 Types of facings.....	13
5.7.2 Jointing face finish.....	13
5.8 Surface finish of flanges and collars.....	14
5.8.1 Surface finish.....	14
5.8.2 Spot facing or back facing of flanges.....	15
5.9 Tolerances.....	15
5.10 Marking.....	15
5.10.1 General marking requirements.....	15
5.10.2 Stamping.....	16
5.10.3 Declaration of compliance.....	16
5.11 Welding.....	16
5.12 Inspection and testing.....	17
5.12.1 Inspection and testing of fusion welded joints.....	17
5.12.2 Inspection and testing of banded and electric welded flanges or collars from formed bars, sectional steel or band material.....	17
5.12.3 Inspection and testing of formed parts manufactured from base material other than forgings.....	18
5.12.4 Inspection and testing of other materials.....	19
5.13 Certificates.....	19
<b>Annex A (normative) Wall thickness and end preparation.....</b>	<b>66</b>
A.1 Weld-end preparation for flanges types 11 and 34.....	66
A.2 Weld-end preparation for type 35.....	69
A.3 Weld end preparation for types 36 and 37.....	70
<b>Annex B (informative) Material groups.....</b>	<b>71</b>
<b>Annex C (informative) Approximate masses of flanges and collars.....</b>	<b>73</b>
<b>Annex D (informative) Additional materials.....</b>	<b>81</b>
<b>Annex E (normative) Basis of flange calculation.....</b>	<b>83</b>
E.1 General.....	83
E.2 Calculation method.....	83
E.3 Basic rules for calculation of flange connection.....	83
<b>2</b>	

E.3.1	General.....	83
E.3.2	Flanges.....	83
E.3.3	Pipes.....	84
E.3.4	Bolting/Tightening.....	84
E.3.5	Gasket.....	85
<b>Annex F (normative) Determination of p/t-ratings.....</b>		<b>86</b>
F.1	General.....	86
F.1.1	Reference temperature (RT).....	86
F.1.2	Application limits and equations.....	86
F.2	Symbols, descriptions and units.....	86
F.2.1	General.....	86
F.2.2	p/t-Ratings for materials with time independent nominal design stress.....	87
F.2.3	p/t-Ratings for materials with time dependent nominal design stress.....	87
F.2.4	Reference value for thickness ( $v_R$ ).....	87
F.2.5	Nominal design stresses and safety factors for mean creep rupture strength.....	87
F.2.6	Flanges made from steel castings.....	88
F.2.7	Rounding of maximum allowable pressure at temperature.....	88
<b>Annex G (normative) p/t-ratings for a selection of EN materials.....</b>		<b>89</b>
G.1	General.....	89
G.1.1	p/t-ratings.....	89
G.1.2	Basics of determination of p/t-ratings (see Annex F).....	89
G.1.3	Application limits for creep range.....	89
G.2	Non-austenitic steels.....	90
G.2.1	General.....	90
G.2.2	List of materials.....	91
G.2.3	p/t-Ratings.....	92
G.3	Austenitic and austenitic-ferritic steels.....	104
G.3.1	General.....	104
G.3.2	List of materials.....	104
G.3.3	p/t-Ratings.....	105
<b>Annex H (informative) Rings for tongue and groove flanges.....</b>		<b>112</b>
<b>Annex I (informative) Flanges with fixed inner diameter.....</b>		<b>113</b>
I.1	General.....	113
I.2	Scope.....	113
<b>Annex J (informative) Mating dimensions for flanges with higher DN.....</b>		<b>116</b>
<b>Annex ZA (normative) Relationship between this European Standard and the Essential Requirements of Directive 97/23/EC.....</b>		<b>118</b>
<b>Bibliography.....</b>		<b>120</b>
<b>National Annex NA (informative) to BS EN 1092-1:2007.....</b>		<b>122</b>

## Foreword

This document (EN 1092-1:2007) has been prepared by Technical Committee CEN/TC 74 "Flanges and their joints", the secretariat of which is held by DIN.

This European Standard shall be given the status of a national standard, either by publication of an identical text or by endorsement, at the latest by February 2008, and conflicting national standards shall be withdrawn at the latest by February 2008.

This document supersedes EN 1092-1:2001.

This document has been prepared under a mandate given to CEN by the European Commission and the European Free Trade Association, and supports essential requirements of EU Directive 97/23/EC.

For relationship with EU Directive(s), see informative Annex ZA, which is an integral part of this document.

EN 1092 consists of the following four parts:

- *Part 1: Steel flanges;*
- *Part 2: Cast iron flanges;*
- *Part 3: Copper alloy flanges;*
- *Part 4: Aluminium alloy flanges.*

According to the CEN/CENELEC Internal Regulations, the national standards organizations of the following countries are bound to implement this European Standard: Austria, Belgium, Bulgaria, Cyprus, Czech Republic, Denmark, Estonia, Finland, France, Germany, Greece, Hungary, Iceland, Ireland, Italy, Latvia, Lithuania, Luxembourg, Malta, Netherlands, Norway, Poland, Portugal, Romania, Slovakia, Slovenia, Spain, Sweden, Switzerland and United Kingdom.

## Introduction

When the Technical Committee CEN/TC 74 commenced its work of producing this European Standard it took as its basis, the International Standard, ISO 7005-1, Steel flanges.

In taking this decision, CEN/TC 74, agreed that this standard would differ significantly from the ISO standard in respect of the following:

- a) whereas ISO 7005-1 included in its scope both the original DIN based flanges and also the original ANSI/ASME based flanges, EN 1092-1 contains only the PN based flanges. CEN/TC 74 has produced a separate series of standards, EN 1759-1, EN 1759-3 and EN 1759-4, dealing with the ANSI/ASME based flanges in their original Class designations;
- b) the opportunity was taken to revise some of the technical requirements applicable to the DIN origin flanges.

Consequently, whilst the mating dimensions, the flange and facing types and designations are compatible with those given in ISO 7005-1, it is important to take account of the following differences which exist in EN 1092-1:

- 1) the p/t ratings of this standard have been reduced in many cases by either limiting the lower temperature ratings which can no longer exceed the PN value, or by increasing the rate at which allowable pressures shall reduce with increase in temperature;
- 2) in addition to the range of PN 2,5 to PN 40 DIN origin flanges contained in the ISO standard, EN 1092-1 also includes flanges up to PN 400.

Major changes against edition 2001:

- i. flanges PN 160, PN 250, PN 320 and PN 400 have been introduced;
- ii. further methods of manufacture have been introduced;
- iii. welding conditions, inspection and testing have been introduced;
- iv. flange facing height  $f_1$  changed back to former DN related dimensions;
- v. further collar types have been introduced;
- vi. materials have been updated;
- vii. new p/t-ratings are related to the flange material;
- viii. rings for tongue and groove flanges have been introduced;
- ix. the following flange types have been re-calculated according to the calculation method in EN 1591-1 with the basic rules as described in Annex E of this standard:
  - flanges type 11 for PN 2,5 to PN 400. Types 12 and 13 have been adjusted to the results for Type 11. As a result the thickness of some flanges above DN 500 had to be increased and the neck thickness had to be adjusted;
  - flanges type 05;
  - flanges type 01;
  - flanges type 02 with 32 resp. 33 up to DN 600 for PN 2,5 to PN 40;
  - flanges types 35, 36 and 37 for PN 10 to PN 40;
  - types 21 and 04 with 34 have not been re-calculated according to EN 1591-1.

## 1 Scope

This European Standard for a single series of flanges specifies requirements for circular steel flanges in PN designations PN 2,5 to PN 400 and nominal sizes from DN 10 to DN 4000.

This European Standard specifies the flange types and their facings, dimensions, tolerances, threading, bolt sizes, flange jointing face surface finish, marking, materials, pressure/ temperature ratings and approximate flange masses.

For the purpose of this European Standard, "flanges" include also lapped ends and collars.

This European Standard applies to flanges manufactured in accordance with the methods described in Table 1.

Non-gasketed pipe joints are outside the scope of this European Standard.

## 2 Normative references

The following referenced documents are indispensable for the application of this document. For dated references, only the edition cited applies. For undated references, the latest edition of the referenced document (including any amendments) applies.

EN 287-1:2004, *Qualification test of welders — Fusion welding — Part 1: Steels*

EN 473:2000, *Non destructive testing — Qualification and certification of NDT personnel — General principles*

EN 571-1:1997, *Non destructive testing — Penetrant testing — Part 1: General principles*

EN 784-5:2002, *Pressure equipment — Part 5: Compliance and Inspection Documentation of Materials*

EN 970:1997, *Non-destructive examination of fusion welds — Visual examination*

EN 1289:1998, *Non-destructive examination of welds — Penetrant testing of welds — Acceptance levels*

EN 1290:1998, *Non-destructive examination of welds — Magnetic particle examination of welds*

EN 1291:1998, *Non-destructive examination of welds — Magnetic particle testing of welds — Acceptance levels*

EN 1333:2006, *Flanges and their joints — Pipework components — Definition and selection of PN*

EN 1418, *Welding personnel — Approval testing of welding operators for fusion welding and resistance weld setters for fully mechanized and automatic welding of metallic materials*

EN 1435:1997, *Non-destructive examination of welds — Radiographic examination of welded joints*

EN 1591-1:2001, *Flanges and their joints — Design rules for gasketed circular flange connections — Part 1: Calculation method*

EN 1708-1:1999, *Welding — Basic weld joint details in steel — Part 1: Pressurized components*

EN 1712:1997, *Non-destructive examination of welds — Ultrasonic examination of welded joints — Acceptance levels*

EN 1714:1997, *Non destructive examination of welds — Ultrasonic examination of welded joints*

EN 4014:2004, *Aerospace series — Inserts, thickwall, self-locking — Design standard*

EN 10028-2:2003, *Flat products made of steels for pressure purposes — Part 2: Non-alloy and alloy steels with specified elevated temperature properties*



- EN 10028-3:2003, *Flat products made of steels for pressure purposes — Part 3: Weldable fine grain steels, normalized*
- EN 10028-4:2003, *Flat products made of steels for pressure purposes — Part 4: Nickel alloy steels with specified low temperature properties*
- EN 10028-7:2000, *Flat products made of steels for pressure purposes — Part 7: Stainless steels*
- EN 10160:1999, *Ultrasonic testing of steel flat product of thickness equal or greater than 6 mm (reflection method)*
- EN 10204:2004, *Metallic products — Types of inspection documents*
- EN 10213-2:1995, *Technical delivery conditions for steel castings for pressure purposes — Part 2: Steel grades for use at room temperature and elevated temperatures*
- EN 10213-3:1995, *Technical delivery conditions for steel castings for pressure purposes — Part 3: Steel grades for use at low temperatures*
- EN 10213-4:1995, *Technical delivery conditions for steel castings for pressure purposes — Part 4: Austenitic and austenitic-ferritic steel grades*
- EN 10216-2:2002, *Seamless steel tubes for pressure purposes — Technical delivery conditions — Part 2: Non-alloy and alloy steel tubes with specified elevated temperature properties*
- EN 10216-3:2002, *Seamless steel tubes for pressure purposes — Technical delivery conditions — Part 3: Alloy fine grain steel tubes*
- EN 10216-4:2002, *Seamless steel tubes for pressure purposes — Technical delivery conditions — Part 4: Non-alloy and alloy steel tubes with specified low temperature properties*
- EN 10216-5:2004, *Seamless steel tubes for pressure purposes — Technical delivery conditions — Part 5: Stainless steel tubes*
- EN 10217-2:2002, *Welded steel tubes for pressure purposes — Technical delivery conditions — Part 2: Electric welded non-alloy and alloy steel tubes with specified elevated temperature properties*
- EN 10217-3:2002, *Welded steel tubes for pressure purposes — Technical delivery conditions — Part 3: Alloy fine grain steel tubes*
- EN 10217-7:2005, *Welded steel tubes for pressure purposes — Technical delivery conditions — Part 7: Stainless steel tubes*
- EN 10220:2002, *Seamless and welded steel tubes — Dimensions and masses per unit length*
- EN 10222-2:1999, *Steel forgings for pressure purposes — Part 2: Ferritic and martensitic steels with specified elevated temperature properties*
- EN 10222-3:1998, *Steel forgings for pressure purposes — Part 3: Nickel steels with specified low temperature properties*
- EN 10222-4:1998, *Steel forgings for pressure purposes — Part 4: Weldable fine grain steels with high proof strength*
- EN 10222-5:1999, *Steel forgings for pressure purposes — Part 5: Martensitic, austenitic and austenitic-ferritic stainless steels*
- EN 10226-3:2005, *Pipe threads where pressure tight joints are made on the threads — Part 3: Verification by means of limit gauges*
- EN 10272:2000, *Stainless steel bars for pressure purposes*
- EN 10273:2000, *Hot rolled weldable steel bars for pressure purposes with specified elevated temperature properties*
- EN 12517-1:2006, *Non-destructive testing of welds — Part 1: Evaluation of welded joints in steel, nickel, titanium and their alloys by radiography — Acceptance levels*

EN ISO 887:2000, *Plain washers for metric bolts, screws and nuts for general purposes — General plan (ISO 887:2000)*

EN ISO 1127:1996, *Stainless steel tubes — Dimensions, tolerances and conventional masses per unit length (ISO 1127:1992)*

EN ISO 5817:2003, *Welding — Fusion-welded joints in steel, nickel, titanium and their alloys (beam welding excluded) — Quality levels for imperfections (ISO 5817:2003)*

EN ISO 6708:1995, *Pipe components — Definition and selection of DN (nominal size) (ISO 6708:1995)*

EN ISO 9692-2:1998, *Welding and allied processes — Joint preparation — Part 2: Submerged arc welding of steels (ISO 9692-2:1998)*

EN ISO 15614-1:2004, *Specification and qualification of welding procedures for metallic materials — Welding procedure test — Part 1: Arc and gas welding of steels and arc welding of nickel and nickel alloys (ISO 15614-1:2004)*

EN ISO 15614-13:2005, *Specification and qualification of welding procedures for metallic materials — Welding procedure test — Part 13: Resistance butt and flash welding (ISO 15614-13:2005)*

ISO 7-1:1994, *Pipe threads where pressure-tight joints are made on the threads — Part 1: Dimensions, tolerances and designation*

ISO 2768-1:1989, *General tolerances — Part 1: Tolerances for linear and angular dimensions without individual tolerance indications*

### 3 Terms and definitions

For the purposes of this document, the following terms and definitions apply.

#### 3.1

##### **DN**

see EN ISO 6708

#### 3.2

##### **PN**

see EN 1333

#### 3.3

##### **maximum allowable pressure, PS**

maximum pressure for which the equipment is designed, as specified by the equipment manufacturer

#### 3.4

##### **maximum allowable temperature, TS**

maximum temperature for which the equipment is designed, as specified by the equipment manufacturer

#### 3.5

##### **pressure equipment manufacturer**

individual or organization that is responsible for the design, fabrication, testing, inspection, installation of pressure equipment and assemblies where relevant

[EN 764-3]

#### 3.6

##### **flange manufacturer**

individual or organization that is responsible for the compliance of the flanges with the requirements of this European Standard

## 3.7

**purchaser**

person or organization that orders products in accordance with this European Standard. The purchaser is not necessarily, but may be, a manufacturer of pressure equipment in accordance with the EU Directive listed in Annex ZA. Where a purchaser has responsibilities under this EU Directive, this European Standard will provide a presumption of conformity with the essential requirements of the Directive so identified in Annex ZA.

## 4 Designation

### 4.1 General

Table 6 specifies the flange types and collar types.

Figures 1 and 2 show flange types and collar types with the relevant flange type numbers. Flanges shall be denoted with "flange type" and the "flange description". Collar components shall be denoted with collar type and the collar description.

Figure 3 shows flange facing types, which may be used with the flanges or components shown in Figures 1 and 2. Flange facings shall be denoted with "type" and the relevant symbol.

The range of DN, applicable to each flange type and collar and to each PN, shall be as given in Table 7, however not all dimensions are existing for each type.

### 4.2 Standard designation

Flanges and collars in accordance with this standard shall be designated with the following:

- a) designation, e.g. flange, lapped end or collar;
- b) number of this European Standard, i.e. EN 1092-1;
- c) number of flange type or collar type in accordance with Figures 1 and 2;
- d) type of flange facing in accordance with Figure 3;
- e) DN (nominal size);
- f) bore diameter only if not according to this standard (for sizes greater than DN 600);
  - $B_1$  (only for types 01, 12 and 32);
  - $B_2$  (only for type 02);
  - $B_3$  (only for type 04);
- g) wall thickness  $S$  only if not according to this European Standard (only for types 11 and 34, 35, 36 and 37);
- h) bevelled wall thickness  $S_p$  if required (only for types 11 and 34 to 37, see Annex A);
- i) PN designation;
- j) for type 13 flanges type of thread ( $R_p$  or  $R_c$ );
- k) and material and material standard (if necessary);
- l) any heat treatment required;

m) type of material certificate, if required (see 5.13).

**EXAMPLE 1** Designation of a flange type 11 with facing type B2 of nominal size DN 200, neck thickness 9 mm, PN 100, made of material P245GH:

Flange EN 1092-1/11/B2/DN 200 × 9/PN 100/P245GH

**EXAMPLE 2** Designation of a flange type 01 of nominal size DN 800, with bore diameter  $B_1 = 818$  mm, PN 6, made of material P265GH:

Flange EN 1092-1/01/DN 800/818/PN 6/P265GH

**EXAMPLE 3** Designation of a collar type 32 of nominal size DN 400, PN 10 and made of material P265GH:

Collar EN 1092-1/32/DN 400/PN 10/P265GH

**EXAMPLE 4** Designation of a flange type 02 of nominal size DN 400, PN 10 and made of material 1.0425:

Flange EN 1092-1/02/DN 400/PN 10/1.0425

## 5 General requirements

### 5.1 Materials

#### 5.1.1 General

Flanges and collars to be used in pressure equipment shall be manufactured from materials fulfilling the essential safety requirements of the Directive 97/23/EC. Materials specifications which meet the requirements for this European Standard are given in Table 9 (see also Annex D).

Collars type 35 to 37 shall only be manufactured of austenitic/austenitic ferritic steel.

The fabricated flange shall fulfil the mechanical properties of the material standard.

**WARNING** — The restrictions of the different material standards have to be followed.

**NOTE 1** The materials given in Table 9 (see also Annex D) are tabulated in groups.

**NOTE 2** The materials of ancillary components (for example rings according to Annex H) are not within the scope of this European Standard.

#### 5.1.2 Methods of manufacture related to base material

Methods of manufacture see Table 1.

Table 1 — Methods of manufacture

Type of Flange and Collar	Forged <sup>a</sup>	Casted	Made from flat products (plates)	Machined from rolled or forged bars and forged sectional steel	Bended and electric welded form bars, sectional steel or strip b, c, d, e	Pressed from welded or seamless pipes or flat products
01 (Plate flange for welding)	yes	no	yes	yes	yes	no
02 (Loose plate flange for Types 32—37)	yes	no	yes	yes	yes	no
04 (Loose plate flange for Type 34)	yes	no	yes	yes	yes	no
05 (Blind flange)	yes	no	yes	yes	no	no
11 (Weld-neck flange)	yes	no	no	yes	yes, for ≥ DN 700	no
12 (Hubbed slip-on flange for welding)	yes	no	no	yes	no	no
13 (Hubbed threaded flange)	yes	no	no	yes	no	no
21 (Integral flange)	yes	yes	no	yes	no	no
32 (Weld-on plate collar)	yes	no	yes	yes	yes	no
33 (Lapped end pipe)	yes	no	yes	yes	yes	yes
34 (Weld-neck collar)	yes	yes	no	yes	yes	no
35 (Welding neck)	yes	no	yes	yes	yes	no
36 (Pressed collar with long neck)	yes	no	no	no	yes	yes
37 (Pressed collar)	yes	no	yes	no	yes	yes

<sup>a</sup> Seamless rolled, pressed, forged.

<sup>b</sup> Only one radial weld is allowed under DN 1800.

<sup>c</sup> For welding see 5.11.

<sup>d</sup> Welded flanges allowed only for an application up to 370 °C in conformance with EN 13480-3:2002, D.4.4.

<sup>e</sup> In case flanges are made by cold forming of a base material e.g. flat product, some mechanical properties, like elongation after fracture (A) and Impact energy (KV), will be impaired due to cold forming without subsequently heat treatment.

## 5.2 Repairs by welding

With the exception of weld repairs according to 5.11 repairs by welding are permitted only by written agreement of the purchaser.

Within the certificate for material or component relevant documents shall be noted, that approved welding procedure and welders qualification (see 5.11) have been applied.

## 5.3 Bolting

Flanges shall be suitable for use with the number and size of bolting as specified in Tables 10 to 21. The bolting shall be chosen by the equipment manufacturer according to the pressure, temperature, flange material and gasket so that the flanged joint remains tight under the expected operating conditions. For selection of bolting, see EN 1515-1, for combination of the materials of flanges and bolting see EN 1515-2, for information.

## 5.4 Gaskets

The various gasket types, dimensions, design characteristics and materials used are not within the scope of this European Standard. Dimensions of gaskets are given in the series of standards EN 1514.

## 5.5 Determination of p/t ratings

p/t ratings for flanges according to this standard shall be calculated in accordance with the rules given in Annex F.

p/t ratings for a selection of EN materials are given in Annex G.

## 5.6 Dimensions

### 5.6.1 Flanges and collars

The dimensions of flanges and collars shall be as given in Tables 8 and 10 to 22 according to the PN designation. Dimension  $G_{\max}$  may be varied from the given value (see NOTE 1) which is a maximum limit. The wall thickness,  $S$  is a minimum value, selected according to pipe thickness  $T$  given in ISO 4200 (see NOTE 2). Outside diameter of neck ( $A$ ) is selected according to EN 10220. The reduced wall thickness  $S_p$  is used in case of unequal  $S$  and  $T$  (type 34 see Table 12 to Table 15 and Annex A).

The following flange types have been re-calculated according to the calculation method in EN 1591-1 with the basic rules as described in Annex E of this European Standard:

- flanges type 11 for PN 2,5 to PN 400. Types 12 and 13 have been adjusted to the results for Type 11. As a result the thickness of some flanges above DN 500 had to be increased and the neck thickness had to be adjusted;
- flanges type 05;
- flanges type 01;
- flanges type 02 with 32 resp. 33 up to DN 600 for PN 2,5 to PN 40;
- flanges types 35, 36 and 37 for PN 10 to PN 40;
- types 21 and 04 with 34 have not been re-calculated according to EN 1591-1.

NOTE 1 The centre portion of the face of a flange type 05 need not be machined provided that the diameter of the unmachined portion does not exceed the recommended diameter for  $G_{\max}$ , given in Tables 10 to 21.

NOTE 2 When requested by the pressure equipment manufacturer/purchaser, wall thickness  $S$ , other than those given in this European Standard, may be supplied by agreement with the flange manufacturer, provided a calculation exists.

NOTE 3 A summary of the various types of flanges specified is given in Table 7 showing the nominal sizes applicable to each type and to each PN.

NOTE 4 Diameters  $N_1$ ,  $N_2$  and  $N_3$  of flange and collar types 11, 12, 13, 21 and 34 are the theoretical values permitting the use of ring spanners or the application of normal series plain washers without any additional machining, e.g. spot facing (see 5.8).

NOTE 5 The bore diameters of flanges type 21 are not specified in this standard, the effective bore diameters are usually given in the relevant component standard(s).

NOTE 6 Approximate masses of flanges and collars are given in Annex C.

NOTE 7 For flanges type 21 dimensions  $A$ ,  $N_3$  and  $R_1$  are nominal values. These dimensions and their tolerances are included for guidance only.

NOTE 8 For the diameter of wall thickness  $S$  respectively beveled wall thickness  $S_p$  see Annex A. For flange type 34 refer to Tables 12 to 15.

### 5.6.2 Hubs

The hubs of flange types 12, 13 and 34 shall be either:

- a) parallel, or
- b) for manufacturing purposes, taper with an angle not exceeding  $7^\circ$  on the outside surface for forging or casting purposes.

Details of the weld end preparation for flanges type 11 and collar types 34 to 37 shall be as given in Annex A.

### 5.6.3 Threaded flanges

5.6.3.1 The threads of flanges type 13 shall be parallel (symbol  $R_p$ ) or tapered (symbol  $R_t$ ) in accordance with ISO 7-1. Gauging shall be in accordance with EN 10226-3.

NOTE Parallel threads will be supplied unless otherwise requested by the purchaser.

5.6.3.2 The thread shall be concentric with the axis of the flange and misalignments shall not exceed 5 mm per metre.

Flanges type 13 shall be manufactured without a parallel counterbore, but to protect the thread they shall be chamfered to the major diameter of the thread at the hubbed side of the flange at an angle between 30° and 50° to the axis of the thread. The chamfer shall be concentric with the thread and shall be included in the measurement of the thread length provided that the chamfer does not exceed one pitch in length.

### 5.6.4 Bolt holes

Bolt holes shall be equally spaced on the pitch circle diameter. In the case of flanges type 21 they shall be positioned such that they are symmetrical to the principal axes and such that no holes fall on these axes i.e. positioned "off-centre", see Figures 5 to 16.

### 5.6.5 Lapped joints

The dimensions of lapped joints to be used with flanges, type 02, are specified in Tables 8 and 10 to 14.

### 5.6.6 Collar types

For collar types 33, 36 and 37 the thickness of the lapped end at the facing shall be not less than the specified wall thickness of the pipe used.

The dimensions of collar types 35, 36 and 37 to be used with flanges type 02 are given in Tables 10 to 14. Type 33 thickness shall be at least the same as for type 37 (see Annex A.3).

## 5.7 Facings

### 5.7.1 Types of facings

The types of facings shall be as given in Figure 3 and their dimensions shall be as given in Figure 4 and Table 8.

For facings types B, D, F and G, the transition from the edge of the raised face to the flange shall be:

- a) radius, or
- b) chamfer

at the choice of the flange manufacturer.

### 5.7.2 Jointing face finish

5.7.2.1 All flange and collar jointing faces, except types 33, 36 and 37, shall be machine finished and shall have a surface finish in accordance with the values given in Table 2 when compared with reference specimens by visual or tactile means.

NOTE It is not intended that instrument measurements be taken on the faces themselves; the  $R_a$  and  $R_z$  values as defined in EN ISO 4287 relate to the reference specimens.

5.7.2.2 For flanges and collars (except types 33, 36 and 37) with facing types A, B1, E and F, turning shall be carried out with a round nosed tool in accordance with Table 2.

5.7.2.3 Flanges type 05 up to PN 40 and collars (except types 33, 36 and 37) shall have type A facing, other flanges shall have type B1 facings; unless type B2 facing is agreed between the purchaser and the supplier.

Table 2 — Surface finish for jointing faces

Facing types	Method of machining	Radius of tool nose	$R_a^a$		$R_z^a$	
		mm	µm		µm	
		min.	min.	max.	min.	max.
A, B1 <sup>b</sup> , E, F	Turning <sup>c</sup>	1,0	3,2	12,5	12,5	50
B2 <sup>b</sup> , C, D, G, H	Turning <sup>c</sup>	—	0,8	3,2	3,2	12,5

NOTE For certain applications, e.g. low temperature gases, it may be necessary to stipulate closer control to the surface finish.

<sup>a</sup>  $R_a$  and  $R_z$  are defined in EN ISO 4287.

<sup>b</sup> Types B1 and B2 are raised face (type B) flanges with different specified surface roughness values.  
 B1 : Standard facing for all PN numbers.  
 B2 : Only if agreed between the purchaser and the flange manufacturer.

<sup>c</sup> The term 'turning' includes any method of machine operation producing either serrated concentric or serrated spiral grooves.

## 5.8 Surface finish of flanges and collars

### 5.8.1 Surface finish

The surface finish of flanges and collars shall be according to Table 3. The given surface roughness values apply to as-delivered condition, unless otherwise specified by the purchaser.



Table 3 — Surface finish

Flange type	Outer diameter		Centre bore diameter		Bolt holes	Spot facing
	Ra max	Rz max	Ra max	Rz max		
01 (Plate flange for welding)	25	160	25	160	b	c
02 (Loose plate flange for Types 32—37)	25	160	25	160	b	
04 (Loose plate flange for Type 34)	25	160	25	160	b	
05 (Blind flange)	25	160	n.a.		b	c
11 (Weld-neck flange)	25 <sup>a</sup>	160 <sup>a</sup>	25 <sup>a</sup>	160 <sup>a</sup>	b	c
12 (Hubbed slip-on flange for welding)	25 <sup>a</sup>	160 <sup>a</sup>	25 <sup>a</sup>	160 <sup>a</sup>	b	c
13 (Hubbed threaded flange)	25 <sup>a</sup>	160 <sup>a</sup>	See thread standard		b	c
21 (Integral flange)	25 <sup>a</sup>	160 <sup>a</sup>	25 <sup>a</sup>	160 <sup>a</sup>		c
32 (Weld-on plate collar)	25	160	25	160		
33 (Lapped end pipe)	25	160	25	160		
34 (Weld-neck collar)	25 <sup>a</sup>	160 <sup>a</sup>	25 <sup>a</sup>	160 <sup>a</sup>		
35 (Welding neck)	25 <sup>a</sup>	160 <sup>a</sup>	25 <sup>a</sup>	160 <sup>a</sup>		
36 (Pressed collar with long neck)	25 <sup>a</sup>	160 <sup>a</sup>	25 <sup>a</sup>	160 <sup>a</sup>		
37 (Pressed collar)	25 <sup>a</sup>	160 <sup>a</sup>	25 <sup>a</sup>	160 <sup>a</sup>		

<sup>a</sup> Or up to PN 40 un-machined.  
<sup>b</sup> Bolt holes > PN 40 only drilled.  
<sup>c</sup> Chip machining spot facing for PN ≥ 63 (see 5.8.2).

### 5.8.2 Spot facing or back facing of flanges

Any spot facing or back facing shall not reduce the flange thickness to less than the flange thickness specified. When spot facing is used, the diameter shall be large enough to accommodate the outside diameter of the equivalent normal series of washers in accordance with EN ISO 887 for the bolt size being fitted. The bearing surfaces for the bolting shall be parallel to the flange face within the limits given in Table 22. When a flange is back faced a minimum fillet radius,  $R_2$  (see Figure 17) in accordance with Table 23 shall be maintained.

## 5.9 Tolerances

Tolerances on dimensions of flanges and collars shall be as given in Table 22.

General tolerances for dimensions without given tolerance: According to ISO 2768-1 — c.

## 5.10 Marking

### 5.10.1 General marking requirements

All flanges, lapped ends and collars, other than type 21 flanges, should be marked as follows:

- flange/collar manufacturer's name or trade mark, e.g. XXX;
- number of this European Standard, i.e. EN 1092-1;
- flange/collar type number;
- DN, e.g. DN 150;
- PN designation, e.g. PN 40 (marking according to synoptic Table 7, other marking with lower PN number, for identical dimensions only, may be specified);

- f) wall thickness (*S*), if not according to this European Standard;
- g) for EN materials — either the name or the number or the grade of the material, e.g. P245GH;
- h) heat number of melt and/or suitable identification, such as code number, for the traceability e.g. A2345, when test certification is required.

EXAMPLE XXX/EN 1092-1/11/DN 150/PN 40/P265GH/A2345

- i) additional marking (*M*) for flanges according to Annex I:

EXAMPLE XXX/EN 1092-1/34M/...

If a part is too small to enable all the markings required then the minimum marking required shall be:

- i. flange/collar manufacturer's name or trade mark;
- ii. letters "EN";
- iii. PN designation e.g. PN 40;
- iv. either the name or the number or the grade of the material;
- v. cast number and/or suitable identification and/or identification number for the traceability of the cast.

#### 5.10.2 Stamping

Marking has to be visible and durable. Where hard stampings are used, the marking shall be positioned on the outer rim of the parts.

NOTE It should be ensured that hard stamping markings are not liable to cause cracks in the flange material.

#### 5.10.3 Declaration of compliance

The marking EN 1092-1, together with the flange manufacturer's name or trademark on or in relation to a product, represents the flange manufacturer's declaration of compliance to this European Standard, i.e. a claim by or on behalf of the flange manufacturer that the product meets the requirements of this European Standard.

### 5.11 Welding

When producing flanges or collars by fusion welding or flanges or collars formed by bending from sections, bar steel or flat products and flash-butt welded the following criteria are valid:

- welding process/procedures shall be qualified and certified in accordance with EN ISO 15614-1 and EN ISO 15614-13;

NOTE Existing valid welding procedures for arc welding of steels i.e. in accordance with EN 288-3 may be used (see introduction to EN ISO 15614-1:2004).

- welders and/or welding operators shall be qualified in accordance with EN 287-1 and/or EN 1418.

All welds shall have full penetration.

Local repair of weld seam with filler metal is permitted, provided that the repair procedure/welders are qualified in accordance with the relevant part of the above mentioned standards.

If heat treatment is required, the repair welding shall be carried out prior to that.

## 5.12 Inspection and testing

### 5.12.1 Inspection and testing of fusion welded joints

- a) Welded joints shall be visually examined in accordance with EN 970 before any other NDT is performed.
- b) The area to be examined shall include the weld metal and the heat affected zones.
- c) The required surface examination shall be performed on all the surfaces.
- d) Any type of NDT shall be performed after any forming or heat treatment operation. Where a material is not sensitive to PWHT cracking (e.g. material groups 1.1 and 8.1 (see CEN ISO/TR 15808)), NDT may be performed before PWHT.
- e) In case of austenitic base or filler material, the method for surface testing shall be PT.
- f) Welded pipe as base material shall conform to the relevant product (pipe) standard (see Table 9).
- g) All other longitudinal welds of necks shall have 100 % volumetric (RT/UT) testing.
- h) For type 35 only: Every 10<sup>th</sup> radial weld of rings shall have 100 % volumetric testing. Every 10<sup>th</sup> ring weld shall have surface crack detection (MT or PT) except in material groups 1.1, 1.2 or 8.1.
- i) For type 35 only: Welding of neck to ring, every 10<sup>th</sup> flange shall have surface crack detection of welds (MT or PT).

Table 4 — NDT methods, techniques, characterisation and acceptance criteria for fusion welded flanges or collars

NDT Methods (abbreviations)	Techniques	Acceptance Criteria
Visual inspection (VT)	EN 970	EN ISO 5817:2003, surface imperfections, Acceptance level B
Radiography (RT)	EN 1435:1997, class B	EN 12517-1:2006, Acceptance level 2 and Table 6.6.4-1
Ultrasonic Testing(UT)	EN 1714:1997, min. class B <sup>a</sup>	EN 1712:1997, Acceptance level 2 + no planar imperfections accepted
Penetrant Testing (PT)	EN 571-1:1997 + test parameter to EN 1289:1998 Table A.1 – Acceptance level 1	EN 1289:1998, Acceptance level 1
Magnetic Particle Testing (MT)	EN 1290:1998 + test parameter to EN 1291:1998, Table A.1 – Acceptance level 1	EN 1291:1998, Acceptance level 1

<sup>a</sup> Thickness  $t < 40$  mm class A is acceptable. By  $t > 100$  mm class C is required.

NDT operators (Level 1) and supervisor (Level 2) shall be qualified and certified in accordance with EN 473.

### 5.12.2 Inspection and testing of bended and electric welded flanges or collars from formed bars, sectional steel or band material

- a) Welded joints shall be visually examined in accordance with EN 970 before any other NDT is performed. Acceptance criteria in accordance with EN ISO 5817 surface imperfections level C.
- b) The area to be examined shall include the weld metal and the heat affected zones.
- c) All base material for these flanges, such as plates or flat products shall be inspected ultrasonically according to EN 10160. Scope of test according to EN 10160:199, Table 3, acceptance criteria Class S<sub>2</sub> and EN 10160:1999, Table 5 Class E<sub>3</sub>.
- d) Flanges made of steels in Material Groups 1E0, 1E1, 2E0 and 3E1 are subjected by the flange manufacturer to ultrasonic testing or to radiographic testing with reference to Table 5 to the extend defined in Table 5. As a rule, flanges that are produced by continuous welding with the same machine setting are grouped together to form a test batch.

- e) Finished flanges of all other material groups are subjected by the flange manufacturer to ultrasonic inspection or to radiographic inspection in the weld zone according to Table 5 on each flange.
- f) Flanges with unit weights > 300 kg shall be inspected ultrasonically or radiographically according to Table 5 in all material groups.
- g) All welds shall be tested by the flange manufacturer for the presence of surface cracks with a suitable method as Penetrant Testing for austenitic base or filler material and Magnetic Particle Testing for Ferritic material according to Table 5. The following materials constitute exceptions: P 235 GH, P 265 GH and P 250 GH.
- h) The non-destructive testing shall be carried out after completion of possible post-weld heat treatment (PWHT). Where a material is not sensitive to PWHT cracking e.g. material groups 1.1 and 8.1 (see CEN ISO/TR 15808), NDT may be performed before PWHT.

**Table 5 — Scope of non-destructive testing for flanges or collars formed by bending and electric welded formed bars, sectional steel or band material**

Number of flanges per test unit	Scope of non-destructive testing	Minimum of:
≥ 1 to ≤ 20	100 %	—
> 20 to ≤ 50	50 %	20 flanges
> 50 to ≤ 200	25 %	25 flanges
> 200 to ≤ 1 000	15 %	50 flanges
> 1 000	10 %	150 flanges

### 5.12.3 Inspection and testing of formed parts manufactured from base material other than forgings

#### 5.12.3.1 Non-destructive testing

The testing of formed parts shall include on each component or batch of identical components (dependent on the material and size of flange), if appropriate:

- wall thickness measurements;
- dimensional checks
- hardness tests (e.g. carbon and low alloy steels);
- ultrasonic testing for internal imperfections in longitudinal and transversal direction (e.g. for thickness above 8 mm);
- examination for surface or near surface imperfections (MT or PT).

Material, heat treatment conditions, heat treatment lot, degree of deformation shall be considered in the definition of the batch (see e.g. EN 10253 standards).

#### 5.12.3.2 Destructive testing for heat treated or hot formed components

Testing shall be performed to verify the heat treatment of the formed parts, and shall include the tests required by the base material specification, e.g.:

- tensile test;
- notch impact test;
- micrographs (e.g. 9 % or 12 % Cr steels);

One set of test per cast, wall thickness range and heat treatment lot shall be performed for flanges and collars with  $PN \times DN > 1\,000$  bar and  $DN > 25$ . The tests shall be performed on test pieces from the component itself, or from test pieces placed together with the components in the heat treatment furnaces. The test results shall fulfil the mechanical properties of the material standard.

#### 5.12.4 Inspection and testing of other materials

Flanges made of forgings, casts, bars, pressed and seamless rolled materials shall be inspected and tested by the material manufacturer in accordance with the appropriate material standard.

#### 5.13 Certificates

The flange manufacturer shall use respective procedures to ensure traceability of material and to avoid material exchange and shall be able to provide respective documentation for the base material used. Under consideration of EN 784-5, the purchaser of the flange may require a test certificate according to EN 10204:2004 (2.1, 3.1 or 3.2), applicable for the respective category. The rules of Directive 97/23/EC and the product specification, which includes the technical delivery conditions, shall be applied. If an inspection certificate 3.1 is required, the quality system of the material manufacturer must fulfil the ESRs in the third paragraph of section 4.3 of Annex I of Directive 97/23/EC.

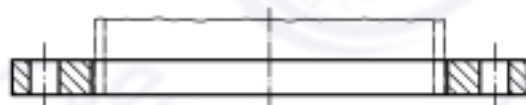

Type 01  
Plate flange for welding



Type 02  
Loose plate flange with weld-on collar (see type 32) or lapped pipe end (see type 33)

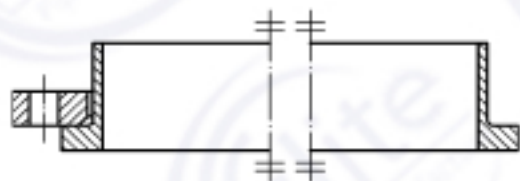

Type 02  
Loose plate flange with weld ring neck (see type 35)

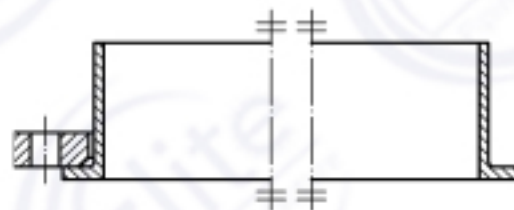

Type 02  
Loose plate flange with pressed collar with long neck (see type 36)

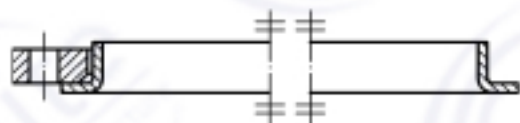

Type 02  
Loose plate flange with pressed collar (see type 37)



Type 04  
Loose plate flange with weld-neck collar (see type 34)

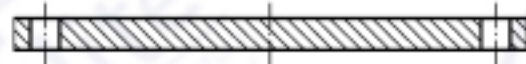

Type 05  
Blind flange

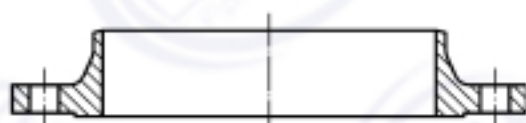

Type 11  
Weld-neck flange

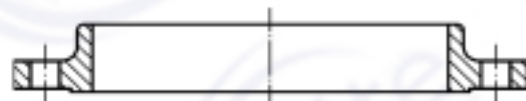

Type 12  
Hubbed slip-on flange for welding

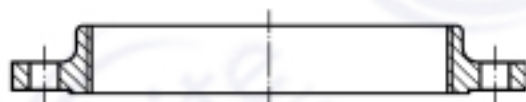

Type 13  
Hubbed threaded flange

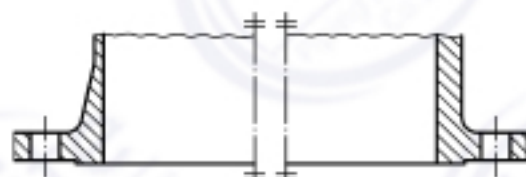

Type 21  
Integral flange

NOTE These sketches are diagrammatic only, in particular no detail is shown for the mating surfaces (see Figure 3).

Figure 1 — Flange types

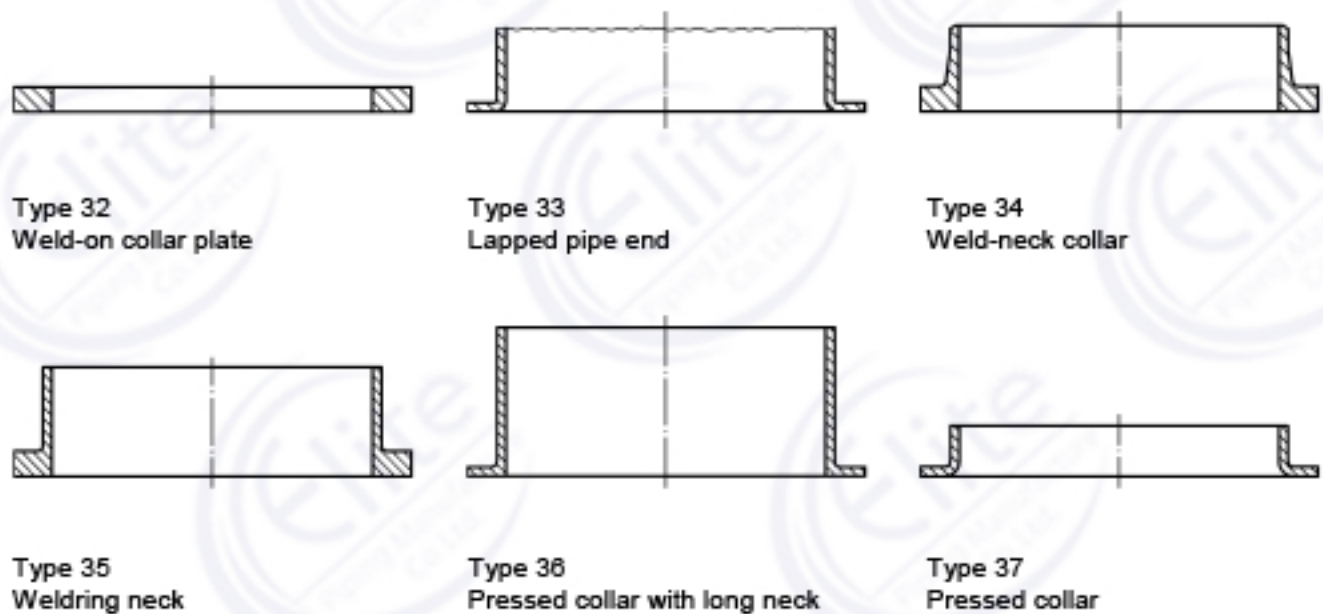

NOTE These sketches are diagrammatic only.

Figure 2 — Collars types 32 to 37

Table 6 — Types of steel flanges and collars

Type No	Description
01	Plate flange for welding
02	Loose plate flange with weld-on plate collar or for lapped pipe end
04	Loose plate flange with weld-neck collar
05	Blind flange
11	Weld-neck flange
12	Hubbed slip-on flange for welding
13	Hubbed threaded flange
21 <sup>a</sup>	Integral flange
32 <sup>b</sup>	Weld-on plate collar
33 <sup>a, b</sup>	Lapped pipe end
34 <sup>b</sup>	Weld-neck collar
35 <sup>b</sup>	Welding neck
36 <sup>b</sup>	Pressed collar with long neck
37 <sup>b</sup>	Pressed collar
NOTE Type numbers have been made non-consecutive to permit possible future additions.	
<sup>a</sup> This is an integral part of a pressure equipment or a component.	
<sup>b</sup> Type numbers 32, 33, 35, 36 and 37 are for use with type 02 flanges and type number 34 for use with type 04 flanges.	

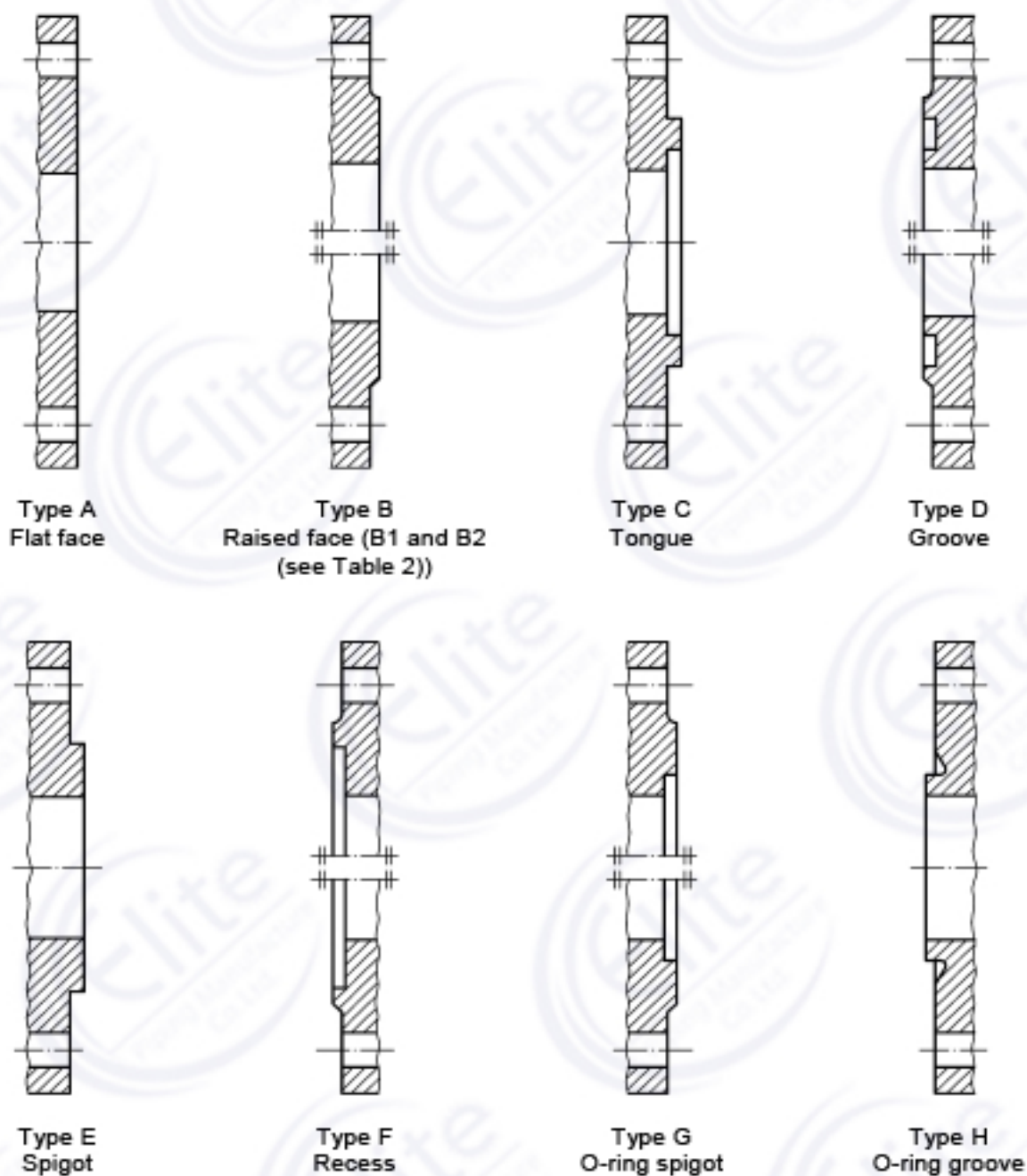

NOTE 1 The transition from the edge of the raised face to the flange face may be by radius or chamfer for types B, D, F and G only (see 5.7.1).

NOTE 2 B1 and B2 are raised face (type B) for different applications (see 5.7.2.2, 5.7.2.3 and Table 2).

NOTE 3 For the dimensions of flange facings, see Figure 4 and Table 8.

Figure 3 — Flange facing types





EN 1092-1:2007 (E)

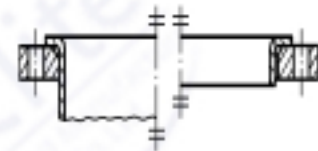
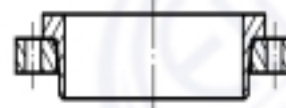

Table 7 (continued)

Flange type or collar type	DN PN	DN																																																							
		10	15	20	25	32	40	50	65	80	100	125	150	200	250	300	350	400	450	500	600	700	800	900	1 000	1 200	1 400	1 600	1 800	2 000	2 200	2 400	2 600	2 800	3 000	3 200	3 400	3 600	3 800	4 000																	
 Type 02 and 36	2,5	dimensions identical with PN 10													X	X																																									
	6	dimensions identical with PN 10													X	X																																									
	10	dimensions identical with PN 16													X	X	X	X	X																																						
	16	X	X	X	X	X	X	X	X	X	X	X	X	X	X	X	X	X	X	X																																					
 Types 02 and 33/37	2,5	dimensions identical with PN 10																																																							
	6	dimensions identical with PN 10																																																							
	10	X	X	X	X	X	X	X	X	X	X	X	X	X	X																																										
	16	X	X	X	X	X	X	X	X	X	X	X	X	X	X																																										
 Types 04 and 34	10	dimensions identical with PN 40							dimensions identical with PN 16							X	X	X	X	X	X	X	X																																		
	16	dimensions identical with PN 40							X	X	X	X	X	X	X	X	X	X	X	X	X	X	X	X	X																																
	25	dimensions identical with PN 40													X	X	X	X	X	X	X	X																																			
	40	X	X	X	X	X	X	X	X	X	X	X	X	X	X	X	X	X	X	X	X	X	X	X	X	X	X	X	X																												



EN 1092-1:2007 (E)

Table 7 (concluded)

Flange type or collar type	DN PN																																																				
		10	15	20	25	32	40	50	65	80	100	125	160	200	250	300	360	400	450	500	600	700	800	900	1 000	1 200	1 400	1 600	1 800	2 000	2 200	2 400	2 600	2 800	3 000	3 200	3 400	3 600	3 800	4 000													
 Type 12	6	X	X	X	X	X	X	X	X	X	X	X	X	X	X																																						
	10	dimensions identical with PN 40					dimensions identical with PN 16					X	X	X	X	X	X	X	X	X																																	
	16	dimensions identical with PN 40					X	X	X	X	X	X	X	X	X	X	X	X	X	X	X	X	X	X	X	X	X	X																									
	25	dimensions identical with PN 40										X	X	X	X	X	X	X	X	X	X	X	X																														
	40	X	X	X	X	X	X	X	X	X	X	X	X	X	X	X	X	X	X	X	X	X	X	X	X	X	X																										
	63	dimensions identical with PN 100					X	X	X	X	X																																										
	100	X	X	X	X	X	X	X	X	X	X	X	X																																								
 Type 13	6	X	X	X	X	X	X	X	X	X	X	X	X	X	X																																						
	10	dimensions identical with PN 40					dimensions identical with PN 16					X	X	X	X	X	X	X	X	X																																	
	16	dimensions identical with PN 40					X	X	X	X	X	X	X	X	X	X	X	X	X	X	X	X	X	X	X	X	X	X	X	X																							
	25	dimensions identical with PN 40										X	X	X	X	X	X	X	X	X	X	X	X	X	X	X	X	X																									
	40	X	X	X	X	X	X	X	X	X	X	X	X	X	X	X	X	X	X	X	X	X	X	X	X	X	X	X																									
	63	dimensions identical with PN 100					X	X	X	X	X																																										
	100	X	X	X	X	X	X	X	X	X	X	X	X																																								
 Type 21	2,5	X	X	X	X	X	X	X	X	X	X	X	X	X	X	X	X	X	X	X	X	X	X	X	X	X	X	X																									
	6	X	X	X	X	X	X	X	X	X	X	X	X	X	X	X	X	X	X	X	X	X	X	X	X	X	X	X	X	X	X	X	X	X	X	X	X	X	X	X	X	X	X	X	X	X	X	X	X				
	10	dimensions identical with PN 40					dimensions identical with PN 16					X	X	X	X	X	X	X	X	X	X	X	X	X	X	X	X	X	X	X	X	X	X	X	X	X	X	X	X	X	X	X	X	X	X	X	X	X	X	X	X	X	
	16	dimensions identical with PN 40					X	X	X	X	X	X	X	X	X	X	X	X	X	X	X	X	X	X	X	X	X	X	X	X	X	X	X	X	X	X	X	X	X	X	X	X	X	X	X	X	X	X	X	X	X		
	25	dimensions identical with PN 40										X	X	X	X	X	X	X	X	X	X	X	X	X	X	X	X	X	X	X	X	X	X	X	X	X	X	X	X	X	X	X	X	X	X	X	X	X	X	X			
	40	X	X	X	X	X	X	X	X	X	X	X	X	X	X	X	X	X	X	X	X	X	X	X	X	X	X	X	X																								
	63	dimensions identical with PN 100					X	X	X	X	X	X	X	X	X	X	X	X	X	X	X	X	X	X	X	X	X	X	X	X																							
	100	X	X	X	X	X	X	X	X	X	X	X	X	X	X	X	X	X	X	X	X	X	X	X	X	X	X	X	X	X	X	X	X	X	X	X	X	X	X	X	X	X	X	X	X	X	X	X	X	X			
	160	X	X	X	X	X	X	X	X	X	X	X	X	X	X	X	X	X	X	X	X	X	X	X	X	X	X	X	X	X	X	X	X	X	X	X	X	X	X	X	X	X	X	X	X	X	X	X	X	X			
	250	X	X	X	X	X	X	X	X	X	X	X	X	X	X	X	X	X	X	X	X	X	X	X	X	X	X	X	X	X	X	X	X	X	X	X	X	X	X	X	X	X	X	X	X	X	X	X	X	X			
	320	X	X	X	X	X	X	X	X	X	X	X	X	X	X	X	X	X	X	X	X	X	X	X	X	X	X	X	X	X	X	X	X	X	X	X	X	X	X	X	X	X	X	X	X	X	X	X	X	X			
400	X	X	X	X	X	X	X	X	X	X	X	X	X	X	X	X	X	X	X	X	X	X	X	X	X	X	X	X	X	X	X	X	X	X	X	X	X	X	X	X	X	X	X	X	X	X	X	X	X				

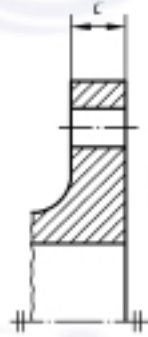

Type A: Flat face

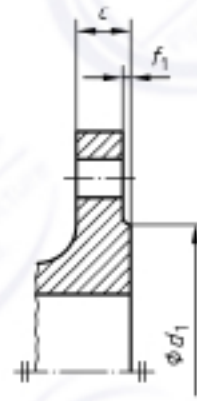

Type B: Raised face (B1 and B2)

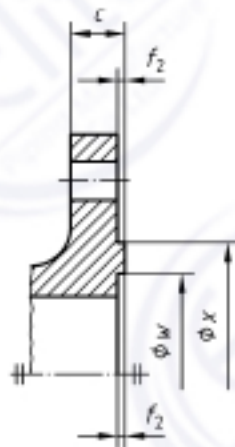

Type C: Tongue

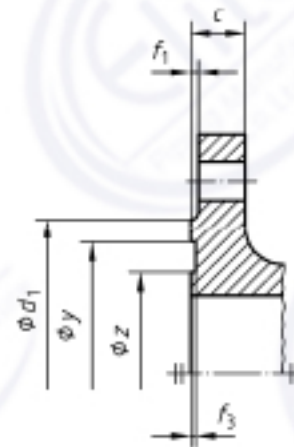

Type D: Groove

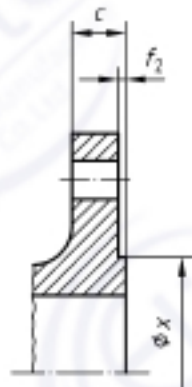

Type E: Spigot

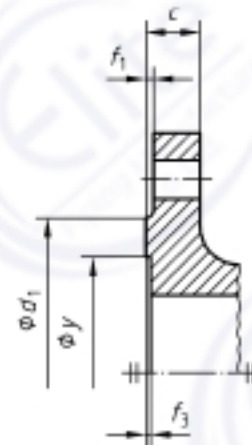

Type F: Recess

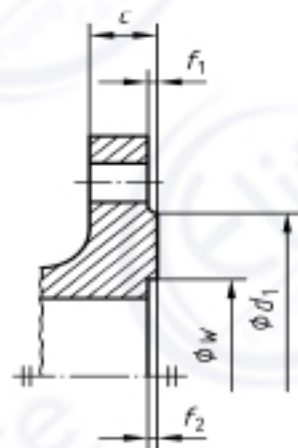

Type G: O-ring spigot

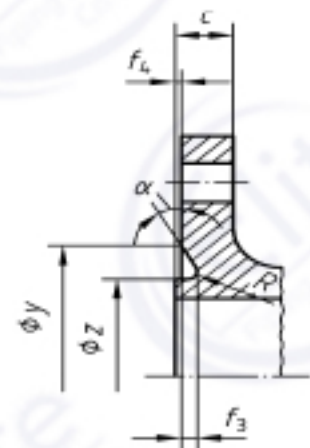

Type H: O-ring groove

NOTE 1 Dimension C includes the raised face thickness.

NOTE 2 Cross section diameter of the O-ring is  $2 \times R$ .

Figure 4 — Flange facing (dimensions see Tables 6 and 8 to 19)

Table 8 — Flange facing dimensions

DN	$d_1$												$f_1$	$f_2$	$f_3$	$f_4$	$w^b$	$x$	$y$	$z^b$	$\alpha_n$	$k$	
	PN 2,5 <sup>a</sup>	PN 6 <sup>a</sup>	PN 10	PN 16	PN 25	PN 40	PN 63	PN 100	PN 160	PN 250	PN 320	PN 400											
	mm	mm	mm	mm	mm	mm	mm	mm	mm	mm	mm	mm											
10	35	35	40	40	40	40	40	40	40	40	40	40	2	4,5	4,0	2,0	24	34	35	23	41°	2,5	
15	40	40	45	45	45	45	45	45	45	45	45	45					29	39	40	28			32°
20	50	50	58	58	58	58	58	58	58	58	58	58					36	50	51	35			
25	60	60	68	68	68	68	68	68	68	68	68	68					43	57	58	42			
32	70	70	78	78	78	78	78	78	78	78	78	78					51	65	66	50			
40	80	80	88	88	88	88	88	88	88	88	88	88					61	75	76	60			
50	90	90	102	102	102	102	102	102	102	102	102	102					73	87	88	72			
65	110	110	122	122	122	122	122	122	122	122	122	122					95	109	110	94			
80	128	128	138	138	138	138	138	138	138	138	138	138					106	120	121	105			
100	148	148	158	158	162	162	162	162	162	162	162	162					129	149	150	128			
125	178	178	188	188	188	188	188	188	188	188	188	188	155	175	176	154							
150	202	202	212	212	218	218	218	218	218	218	218	218	183	203	204	182							
200	258	258	268	268	278	285	285	285	285	285	285	285	239	259	260	238							
250	312	312	320	320	335	345	345	345	345	345	345	345	292	312	313	291							
300	365	365	370	378	395	410	410	410	410	—	—	—	343	363	364	342							
350	415	415	430	438	450	465	465	465	—	—	—	—	395	421	422	394							
400	465	465	482	490	505	535	535	535	—	—	—	—	447	473	474	446							
450	520	520	532	550	555	560	560	560	—	—	—	—	497	523	524	496							
500	570	570	585	610	615	615	615	615	—	—	—	—	549	575	576	548							
600	670	670	685	725	720	735	735	—	—	—	—	—	649	675	676	648							
700	775	775	800	795	820	840	840	—	—	—	—	—	751	777	778	750							
800	880	880	905	900	930	960	960	—	—	—	—	—	856	882	883	855							
900	980	980	1 005	1 000	1 030	1 070	1 070	—	—	—	—	—	961	987	988	960							
1 000	1 080	1 080	1 110	1 115	1 140	1 180	1 180	—	—	—	—	—	1 062	1 092	1 094	1 060							
1 200	1 280	1 295	1 330	1 330	1 350	1 380	1 380	—	—	—	—	—	1 262	1 292	1 294	1 260							
1 400	1 480	1 510	1 535	1 530	1 560	1 600	—	—	—	—	—	—	1 462	1 492	1 494	1 460							
1 600	1 690	1 710	1 760	1 750	1 780	1 815	—	—	—	—	—	—	1 662	1 692	1 694	1 660							
1 800	1 890	1 920	1 960	1 950	1 985	—	—	—	—	—	—	—	1 862	1 892	1 894	1 860							
2 000	2 090	2 125	2 170	2 150	2 210	—	—	—	—	—	—	—	2 062	2 092	2 094	2 060							
2 200	2 295	2 335	2 370	—	—	—	—	—	—	—	—	—	—	—	—	—	—	—	—	—			
2 400	2 495	2 545	2 570	—	—	—	—	—	—	—	—	—	—	—	—	—	—	—	—	—			
2 600	2 695	2 750	2 780	—	—	—	—	—	—	—	—	—	—	—	—	—	—	—	—	—			
2 800	2 910	2 960	3 000	—	—	—	—	—	—	—	—	—	—	—	—	—	—	—	—	—			
3 000	3 110	3 160	3 210	—	—	—	—	—	—	—	—	—	—	—	—	—	—	—	—	—			
3 200	3 310	3 370	—	—	—	—	—	—	—	—	—	—	—	—	—	—	—	—	—	—			
3 400	3 510	3 580	—	—	—	—	—	—	—	—	—	—	—	—	—	—	—	—	—	—			
3 600	3 720	3 790	—	—	—	—	—	—	—	—	—	—	—	—	—	—	—	—	—	—			
3 800	3 920	—	—	—	—	—	—	—	—	—	—	—	—	—	—	—	—	—	—	—			
4 000	4 120	—	—	—	—	—	—	—	—	—	—	—	—	—	—	—	—	—	—	—			

<sup>a</sup> Flange facing types C, D, E, F, G and H according to Figure 4 are not used for PN 2,5 and 6.

<sup>b</sup> Flange facing types G and H according to Figure 4 are only used for PN 10 to PN 40.

Table 9 — Material selection for the manufacturing of flanges

Group	Forgings			Flat products			Castings			Bars		
	Material name	Standard	Material number	Material name	Standard	Material number	Material name	Standard	Material number	Material name	Standard	Material number
2E0	—	—	—	—	—	—	GP240GR	EN 10213-2	1.0621	—	—	—
3E0	—	—	—	P235GH	EN 10028-2	1.0345	GP240GH	EN 10213-2	1.0619	P235GH	EN 10273	1.0345
3E0	—	—	—	—	—	—	—	—	—	P250GH	EN 10273	1.0460
3E0	P245GH	EN 10222-2	1.0352	P265GH	EN 10028-2	1.0425	GP280GH	EN 10213-2	1.0625	P265GH	EN 10273	1.0425
3E1	P280GH	EN 10222-2	1.0426	P295GH	EN 10028-2	1.0481	—	—	—	P295GH	EN 10273	1.0481
4E0	16Mo3	EN 10222-2	1.5415	16Mo3	EN 10028-2	1.5415	G20Mo5	EN 10213-2	1.5419	16Mo3	EN 10273	1.5415
5E0	13CrMo4-5	EN 10222-2	1.7335	13CrMo4-5	EN 10028-2	1.7335	G17CrMo5-5	EN 10213-2	1.7357	13CrMo4-5	EN 10273	1.7335
6E0	11CrMo9-10	EN 10222-2	1.7383	12CrMo9-10	EN 10028-2	1.7375	G17CrMo9-10	EN 10213-2	1.7379	11CrMo9-10	EN 10273	1.7383
	—	—	—	10CrMo9-10	EN 10028-2	1.7380	—	—	—	10CrMo9-10	EN 10273	1.7380
6E1	X16CrMo5-1+NT	EN 10222-2	1.7366	—	—	—	GX15CrMo5	EN 10213-2	1.7365	—	—	—
7E0	—	—	—	P275NL1	EN 10028-3	1.0488	G17Mn5	EN 10213-3	1.1131	—	—	—
	—	—	—	P275NL2	EN 10028-3	1.1104	G20Mn5	EN 10213-3	1.6220	—	—	—
7E1	—	—	—	P355NL1	EN 10028-3	1.0566	—	—	—	—	—	—
	—	—	—	P355NL2	EN 10028-3	1.1106	—	—	—	—	—	—
7E2	15NiMn6	EN 10222-3	1.6228	15NiMn6	EN 10028-4	1.6228	G9Ni10	EN 10213-3	1.5636	—	—	—
	—	—	—	11MnN5-3	EN 10028-4	1.6212	—	—	—	—	—	—
	13MnNi6-3	EN 10222-3	1.6217	13MnNi6-3	EN 10028-4	1.6217	—	—	—	—	—	—
7E3	—	—	—	—	—	—	—	—	—	—	—	—
	12Ni14	EN 10222-3	1.5637	12Ni14	EN 10028-4	1.5637	G9Ni14	EN 10213-3	1.5638	—	—	—
	X12Ni5	EN 10222-3	1.5680	X12Ni5	EN 10028-4	1.5680	—	—	—	—	—	—
	X8Ni9	EN 10222-3	1.5662	X8Ni9	EN 10028-4	1.5662	—	—	—	—	—	—
8E0	—	—	—	—	—	—	—	—	—	—	—	
8E2	P285NH	EN 10222-4	1.0477	P275NH	EN 10028-3	1.0487	—	—	—	P275NH	EN 10273	1.0487
	P285QH	EN 10222-4	1.0478	—	—	—	—	—	—	—	—	—
8E3	P355NH	EN 10222-4	1.0565	P355N	EN 10028-3	1.0562	—	—	—	P355NH	EN 10273	1.0565
	P355QH1	EN 10222-4	1.0571	P355NH	EN 10028-3	1.0565	—	—	—	P355QH	EN 10273	1.8867
9E0	X20CrMoV11-1	EN 10222-2	1.4922	—	—	—	GX23CrMoV12-1	EN 10213-2	1.4931	—	—	—
9E1	X10CrMoVNb9-1	EN 10222-2	1.4903	X10CrMoVNb9-1	EN 10028-2	1.4903	—	—	—	—	—	—
10E0	X2CrNi18-9	EN 10222-5	1.4307	X2CrNi18-9	EN 10028-7	1.4307	GX2CrNi19-11	EN 10213-4	1.4309	X2CrNi18-9	EN 10272	1.4307
	—	—	—	X2CrNi19-11	EN 10028-7	1.4306	—	—	—	X2CrNi19-11	EN 10272	1.4306
10E0	—	—	—	X1CrNi25-21	EN 10028-7	1.4335	—	—	—	—	—	—
10E1	X2CrNi18-10	EN 10222-5	1.4311	X2CrNi18-10	EN 10028-7	1.4311	—	—	—	X2CrNi18-10	EN 10272	1.4311
11E0	X5CrNi18-10	EN 10222-5	1.4301	X5CrNi18-10	EN 10028-7	1.4301	GX5CrNi19-10	EN 10213-4	1.4308	X5CrNi18-10	EN 10272	1.4301
	X6CrNi18-10	EN 10222-5	1.4948	X6CrNi18-10	EN 10028-7	1.4948	—	—	—	—	—	—



Table 9 (continued)

Group	Forgings			Flat products			Castings			Bars		
	Material name	Standard	Material number	Material name	Standard	Material number	Material name	Standard	Material number	Material name	Standard	Material number
12E0	X8CrNiTi18-10	EN 10222-5	1.4541	X8CrNiTi18-10	EN 10028-7	1.4541	—	—	—	X8CrNiTi18-10	EN 10272	1.4541
	X8CrNiNb18-10	EN 10222-5	1.4550	X8CrNiNb18-10	EN 10028-7	1.4550	GX5CrNiNb19-11	EN 10213-4	1.4552	X8CrNiNb18-10	EN 10272	1.4550
	X8CrNiTiB18-10	EN 10222-5	1.4941	X8CrNiTiB18-10	EN 10028-7	1.4941	—	—	—	—	—	—
13E0	X2CrNiMo17-12-2	EN 10222-5	1.4404	X2CrNiMo17-12-2	EN 10028-7	1.4404	GX2CrNiMo19-11-2	EN 10213-4	1.4409	X2CrNiMo17-12-2	EN 10272	1.4404
	X2CrNiMo17-12-3	EN 10222-5	1.4432	X2CrNiMo17-12-3	EN 10028-7	1.4432	—	—	—	X2CrNiMo17-12-3	EN 10272	1.4432
	X2CrNiMo18-14-3	EN 10222-5	1.4435	X2CrNiMo18-14-3	EN 10028-7	1.4435	—	—	—	X2CrNiMo18-14-3	EN 10272	1.4435
	X1NiCrMoCu2.5-20-5	EN 10222-5	1.4539	X1NiCrMoCu2.5-20-5	EN 10028-7	1.4539	GX2NiCrMo28-20-2	EN 10213-4	1.4458	X1NiCrMoCu2.5-20-5	EN 10272	1.4539
	—	—	—	X1NiCrMoCu31-27-4	EN 10028-7	1.4563	—	—	—	X1NiCrMoCu31-27-4	EN 10272	1.4563
13E1	X2CrNiMoN17-11-2	EN 10222-5	1.4406	X2CrNiMoN17-11-2	EN 10028-7	1.4406	—	—	—	X2CrNiMoN17-11-2	EN 10028-7	1.4406
13E1	X2CrNiMoN17-13-3	EN 10222-5	1.4429	X2CrNiMoN17-13-3	EN 10028-7	1.4429	—	—	—	X2CrNiMoN17-13-3	EN 10028-7	1.4429
13E1	—	—	—	X2CrNiMoN17-13-5	EN 10028-7	1.4439	—	—	—	X2CrNiMoN17-13-5	EN 10028-7	1.4439
13E1	—	—	—	X1NiCrMoCuN25-20-7	EN 10028-7	1.4529	—	—	—	X1NiCrMoCuN25-20-7	EN 10028-7	1.4529
13E1	—	—	—	X1CrNiMoCuN20-18-7	EN 10028-7	1.4547	—	—	—	X1CrNiMoCuN20-18-7	EN 10272	1.4547
14E0	X5CrNiMo17-12-2	EN 10222-5	1.4401	X5CrNiMo17-12-2	EN 10028-7	1.4401	GX5CrNiMo19-11-2	EN 10213-4	1.4408	X5CrNiMo17-12-2	EN 10272	1.4401
14E0	X3CrNiMo17-13-3	EN 10222-5	1.4436	X3CrNiMo17-13-3	EN 10028-7	1.4436	—	—	—	X3CrNiMo17-13-3	EN 10272	1.4436
15E0	X8CrNiMoTi17-12-2	EN 10222-5	1.4571	X8CrNiMoTi17-12-2	EN 10028-7	1.4571	—	—	—	X8CrNiMoTi17-12-2	EN 10272	1.4571
	—	—	—	X8CrNiMoNb17-12-2	EN 10028-7	1.4580	GX5CrNiMoNb19-11-2	EN 10213-4	1.4581	X8CrNiMoNb17-12-2	EN 10272	1.4580
16E0	—	—	—	—	—	—	GX2CrNiMoCuN25-6-3-3	EN 10213-4	1.4517	—	—	—
	—	—	—	X2CrNiN23-4	EN 10028-7	1.4362	—	—	—	X2CrNiN23-4	EN 10272	1.4362
	X2CrNiMoN22-5-3	EN 10222-5	1.4462	X2CrNiMoN22-5-3	EN 10028-7	1.4462	GX2CrNiMoN22-5-3	EN 10213-4	1.4470	X2CrNiMoN22-5-3	EN 10272	1.4462
	X2CrNiMoN25-7-4	EN 10222-5	1.4410	X2CrNiMoN25-7-4	EN 10028-7	1.4410	—	—	—	X2CrNiMoN25-7-4	EN 10272	1.4410
	—	—	—	—	—	—	GX2CrNiMoN26-7-4	EN 10213-4	1.4469	—	—	—

Table 9 (continued)

Group	Seamless tubes			Welded tubes		
	Material name	Standard	Material number	Material name	Standard	Material number
2E0	—	—	—	—	—	—
3E0	P195GH	EN 10216-2	1.0348	P195GH	EN 10217-2	1.0348
	P235GH	EN 10216-2	1.0345	P235GH	EN 10217-2	1.0345
3E1	P265GH	EN 10216-2	1.0425	P265GH	EN 10217-2	1.0425
4E0	16Mo3	EN 10216-2	1.5415	16Mo3	EN 10217-2	1.5415
5E0	13CrMo4-5	EN 10216-2	1.7335	—	—	—
6E0	10CrMo9-10	EN 10216-2	1.7380	—	—	—
6E0	11CrMo9-10	EN 10216-2	1.7383	—	—	—
6E1	X11CrMo5-1+NT1	EN 10216-2	1.7362+NT1	—	—	—
7E0	P275NL1	EN 10216-3	1.0488	P275NL1	EN 10217-3	1.0488
	P275NL2	EN 10216-3	1.1104	P275NL2	EN 10217-3	1.1104
7E1	P355NL1	EN 10216-3	1.0566	P355NL1	EN 10217-3	1.0566
	P355NL2	EN 10216-3	1.1106	P355NL2	EN 10217-3	1.1106
7E2	12Ni14	EN 10216-4	1.5637	—	—	—
	X10Ni9	EN 10216-4	1.5682	—	—	—
7E3	13MnNi6-3	EN 10216-4	1.6217	—	—	—
8E0	P275NL1	EN 10216-3	1.0488	P275NL1	EN 10217-3	1.0488
8E0	P275NL2	EN 10216-3	1.1104	P275NL2	EN 10217-3	1.1104
8E2	—	—	—	—	—	—
8E3	P355NH	EN 10216-3	1.0565	P355NH	EN 10217-3	1.0565
9E0	X20CrMoV11-1	EN 10216-2	1.4922	—	—	—
9E1	X10CrMoVNb9-1	EN 10216-2	1.4903	—	—	—
10E0	X2CrNi18-9	EN 10216-5	1.4307	X2CrNi18-9	EN 10217-7	1.4307
	X2CrNi19-11	EN 10216-5	1.4306	X2CrNi19-11	EN 10217-7	1.4306
	X1CrNi25-21	EN 10216-5	1.4335	—	—	—
10E1	X2CrNi18-10	EN 10216-5	1.4311	X2CrNi18-10	EN 10217-7	1.4311
11E0	X5CrNi18-10	EN 10216-5	1.4301	X5CrNi18-10	EN 10217-7	1.4301
11E0	X6CrNi18-10	EN 10216-5	1.4948	—	—	—
12E0	X6CrNiTi18-10	EN 10216-5	1.4541	X6CrNiTi18-10	EN 10217-7	1.4541
	X6CrNiNb18-10	EN 10216-5	1.4550	X6CrNiNb18-10	EN 10217-7	1.4550
	X7CrNiTi18-10	EN 10216-5	1.4940	—	—	—
	X7CrNiTiB18-10	EN 10216-5	1.4941	—	—	—
	X7CrNiNb18-10	EN 10216-5	1.4912	—	—	—
	X8CrNiNb16-13	EN 10216-5	1.4961	—	—	—

Table 9 (concluded)

Group	Seamless tubes			Welded tubes		
	Material name	Standard	Material number	Material name	Standard	Material number
13E0	X2CrNiMo17-12-2	EN 10216-5	1.4404	X2CrNiMo17-12-2	EN 10217-7	1.4404
	—	—	—	X2CrNiMo17-12-3	EN 10217-7	1.4432
	X2CrNiMo18-14-3	EN 10216-5	1.4435	X2CrNiMo18-14-3	EN 10217-7	1.4435
	X1NiCrMoCu25-20-5	EN 10216-5	1.4539	X1NiCrMoCu25-20-5	EN 10217-7	1.4539
	X1NiCrMoCu31-27-4	EN 10216-5	1.4563	X1NiCrMoCu31-27-4	EN 10217-7	1.4563
	—	—	—	X2CrNiMoN18-15-4	EN 10217-7	1.4438
	X6CrNiMo17-13-2	EN 10216-5	1.4918	—	—	—
13E1	X2CrNiMoN17-13-3	EN 10216-5	1.4429	X2CrNiMoN17-13-3	EN 10217-7	1.4429
	X2CrNiMoN17-13-5	EN 10216-5	1.4439	X2CrNiMoN17-13-5	EN 10217-7	1.4439
	X1CrNiMoN25-22-2	EN 10216-5	1.4466	—	—	—
	X1CrNiMoCuN20-18-7	EN 10216-5	1.4547	X1CrNiMoCuN20-18-7	EN 10217-7	1.4547
	X1NiCrMoCuN25-20-7	EN 10216-5	1.4529	X1NiCrMoCuN25-20-7	EN 10217-7	1.4529
14E0	X5CrNiMo17-12-2	EN 10216-5	1.4401	X5CrNiMo17-12-2	EN 10217-7	1.4401
	X3CrNiMo17-13-3	EN 10216-5	1.4436	X3CrNiMo17-13-3	EN 10217-7	1.4436
15E0	X6CrNiMoTi17-12-2	EN 10216-5	1.4571	X6CrNiMoTi17-12-2	EN 10217-7	1.4571
	X6CrNiMoNb17-12-2	EN 10216-5	1.4580	—	—	—
16E0	X2CrNiMoS18-5-3	EN 10216-5	1.4424	—	—	—
	X2CrNiMoN22-5-3	EN 10216-5	1.4462	X2CrNiMoN22-5-3	EN 10217-7	1.4462
	X2CrNiN23-4	EN 10216-5	1.4362	X2CrNiN23-4	EN 10217-7	1.4362
	X2CrNiMoN25-7-4	EN 10216-5	1.4410	X2CrNiMoN25-7-4	EN 10217-7	1.4410
	X2CrNiMoCuN25-6-3	EN 10216-5	1.4507	—	—	—
	X2CrNiMoCuWN25-7-4	EN 10216-5	1.4501	X2CrNiMoCuWN25-7-4	EN 10217-7	1.4501

EN 1092-1:2007 (E)

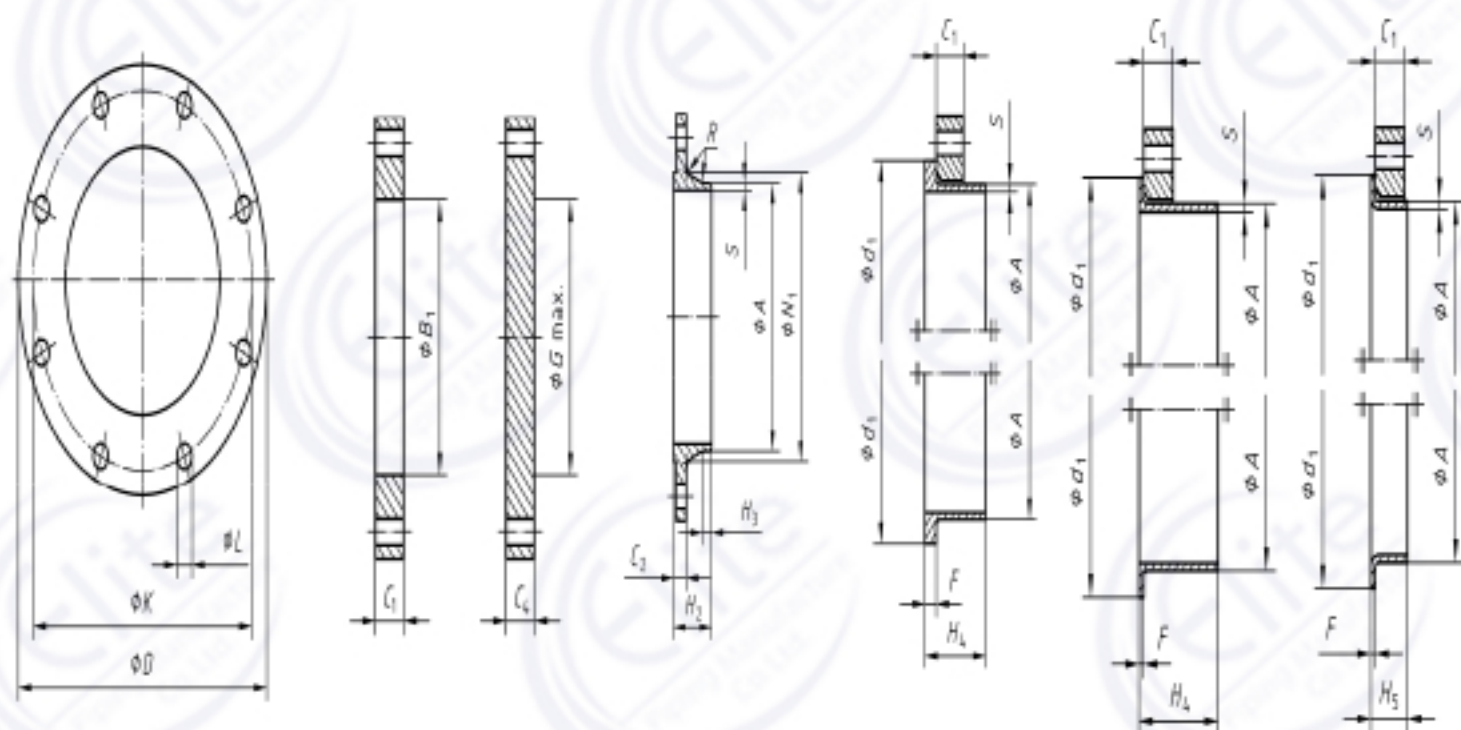

This diagram illustrates the arrangement but not necessarily the correct number of bolt holes.

Type 01

Type 05

Type 11

Type 02 and 35

Type 02 and 36

Type 02 and 37

Refer to the column "Bolt Number" in Table 10 for actual number.



Type 21

NOTE 1 Dimension  $N_3$  is measured at the intersection of the hub draft angle and the back face of the flange.

NOTE 2 For dimension  $G_{max}$ , refer to NOTE 1 of 5.6.1.

Figure 5 — Dimensions of PN 2,5 flanges

Table 10 — Dimensions of PN 2,5 flanges

Dimensions in millimetres

DN	Mating dimensions					Outside diameter of neck A	Bore diameters			Flange thickness				Collar thickness				Diameter of shoulder G <sub>max</sub>	Length					Neck diameters		Corner radii R <sub>1</sub>	Wall thickness (see 5.6.1) S
	Outside diameter D	Diameter of bolt circle K	Diameter of bolt hole L	Bolting			B <sub>1</sub>	B <sub>2</sub>	C <sub>1</sub>	C <sub>2</sub>	C <sub>3</sub>	C <sub>4</sub>	F				H <sub>2</sub>		H <sub>3</sub>	H <sub>4</sub>	H <sub>5</sub>	N <sub>1</sub>	N <sub>2</sub>				
				Number	Size																						
	Flange type																										
01, 02, 05, 11, 21					11 21	01 32	02	01 02	11 21	05	32	35	36	37	05	11	11	35	36	37	11	21	11 13	11, 35 to 37			
10	75	50	11	4	M10	17,2	18,0	21	12	12	12	10	5	2	2,5	—	28	6	28	35	7	26	20	4			
15	80	55	11	4	M10	21,3	22,0	25	12	12	12	10	5	2	2,5	—	30	6	30	38	7	30	26	4			
20	90	65	11	4	M10	26,9	27,5	31	14	14	14	10	6	2,5	3	—	32	6	32	40	8	38	34	4			
25	100	75	11	4	M10	33,7	34,5	38	14	14	14	10	7	2,5	3	—	35	6	35	40	10	42	44	4			
32	120	90	14	4	M12	42,4	43,5	46	16	14	14	10	8	3	3	—	35	6	35	42	12	55	54	6			
40	130	100	14	4	M12	48,3	49,5	53	16	14	14	10	8	3	3	—	38	7	38	45	15	62	64	6			
50	140	110	14	4	M12	60,3	61,5	65	16	14	14	12	8	3	3	—	38	8	38	45	20	74	74	6			
65	160	130	14	4	M12	76,1	77,5	81	16	14	14	12	8	3	3	55	38	9	38	45	20	88	94	6			
80	190	150	18	4	M16	88,9	90,5	94	18	16	16	12	10	3	4	70	42	10	42	50	25	102	110	8			
100	210	170	18	4	M16	114,3	116,0	120	18	16	16	14	10	4	4	90	45	10	45	52	25	130	130	8			
125	240	200	18	8	M16	139,7	141,5	145	20	18	18	14	10	4	4	115	48	10	48	55	25	155	160	8			
150	265	225	18	8	M16	168,3	170,5	174	20	18	18	14	10	5	4	140	48	12	48	55	25	184	182	10			
200	320	280	18	8	M16	219,1	221,5	226	22	20	20	16	11	5	5	190	55	15	55	62	30	236	238	10			
250	375	335	18	12	M16	273,0	276,5	281	24	22	22	18	12	8	—	235	60	15	60	68	—	290	284	12			
300	440	395	22	12	M20	323,9	327,5	333	24	22	22	18	12	8	—	285	62	15	62	68	—	342	342	12			
350	490	445	22	12	M20	355,6	359,5	365	26	22	22	18	13	8	—	330	62	15	62	68	—	385	392	12			
400	540	495	22	16	M20	406,4	411,0	416	28	22	22	20	14	8	—	380	65	15	65	72	—	438	442	12			
450	595	550	22	16	M20	457,0	462,0	467	30	22	24	20	15	8	—	425	65	15	65	72	—	492	494	12			
500	645	600	22	20	M20	508,0	513,5	519	30	24	24	22	16	8	—	475	68	15	68	75	—	538	544	12			
600	755	705	26	20	M24	610,0	616,5	622	32	30	30	22	16	—	—	575	70	16	70	—	—	640	642	12			
700	860	810	26	24	M24	711,0	—	721	40	30	40	—	16	—	—	670	76	16	70	—	—	740	746	12			
800	975	920	30	24	M27	813,0	—	824	44	30	44	—	16	—	—	770	76	16	70	—	—	842	850	12			
900	1 075	1 020	30	24	M27	914,0	<sup>a</sup>	926	48	30	48	—	16	—	—	860	74	16	70	—	—	942	950	12			
1 000	1 175	1 120	30	28	M27	1 016,0	—	1 028	52	30	52	—	18	—	—	960	74	16	70	—	—	1 045	1 050	16			
1 200	1 375	1 320	30	32	M27	1 219	—	1 234	60	32	50	—	20	—	—	1 160	94	16	90	—	—	1 245	—	16			

See Annex A

Table 10 (continued)

Dimensions in millimetres

DN	Mating dimensions				Outside diameter of neck A	Bore diameters		Flange thickness				Collar thickness					Diameter of shoulder G <sub>max</sub>	Length					Neck diameters		Corner radii R <sub>1</sub>	Wall thickness (see 5.6.1) S
	Outside diameter D	Diameter of bolt circle K	Diameter of bolt hole L	Bolting		B <sub>1</sub>	B <sub>2</sub>	C <sub>1</sub>	C <sub>2</sub>	C <sub>3</sub>	C <sub>4</sub>	F						H <sub>2</sub>	H <sub>3</sub>	H <sub>4</sub>	H <sub>5</sub>	N <sub>1</sub>	N <sub>2</sub>			
				Number								Size	Flange type													
	01, 02, 05, 11, 21					11 21 35—37	01 32	02	01 02	11 21	05	32	35	36	37	05		11	11	35	36	37	11	21		
1 400	1 575	1 520	30	36	M27	1 422	—	—	—	38	—	—	—	—	1 346	96	16	—	—	—	1 445	—	16	See Annex A		
1 600	1 790	1 730	30	40	M27	1 626	a	—	—	46	—	—	—	—	1 546	102	20	—	—	—	1 645	—	16			
1 800	1 990	1 930	30	44	M27	1 829	—	—	—	46	—	—	—	—	1 746	110	20	—	—	—	1 845	—	16			
2 000	2 190	2 130	30	48	M27	2 032	—	—	—	50	—	—	—	—	1 950	122	22	—	—	—	2 045	—	16			
2 200	2 405	2 340	33	52	M30	2 235	—	—	—	56	—	—	—	—	—	129	25	—	—	—	2 248	—	18			
2 400	2 605	2 540	33	56	M30	2 438	—	—	—	62	—	—	—	—	—	143	25	—	—	—	2 448	—	18			
2 600	2 805	2 740	33	60	M30	2 620	—	—	—	64	—	—	—	—	—	148	25	—	—	—	2 648	—	18			
2 800	3 030	2 960	36	64	M33	2 820	—	—	—	74	—	—	—	—	—	161	25	—	—	—	2 848	—	18			
3 000	3 230	3 160	36	68	M33	3 020	—	—	—	80	—	—	—	—	—	170	25	—	—	—	3 050	—	18			
3 200	3 430	3 360	36	72	M33	3 220	—	—	—	84	—	—	—	—	—	180	25	—	—	—	3 250	—	20			
3 400	3 630	3 560	36	76	M33	3 420	—	—	—	90	—	—	—	—	—	194	28	—	—	—	3 450	—	20			
3 600	3 840	3 770	36	80	M33	3 620	—	—	—	96	—	—	—	—	—	201	28	—	—	—	3 652	—	20			
3 800	4 045	3 970	39	80	M36	3 820	—	—	—	102	—	—	—	—	—	212	28	—	—	—	3 852	—	20			
4 000	4 245	4 170	39	84	M36	4 020	—	—	—	106	—	—	—	—	—	226	28	—	—	—	4 052	—	20			

<sup>a</sup> To be specified by the purchaser.

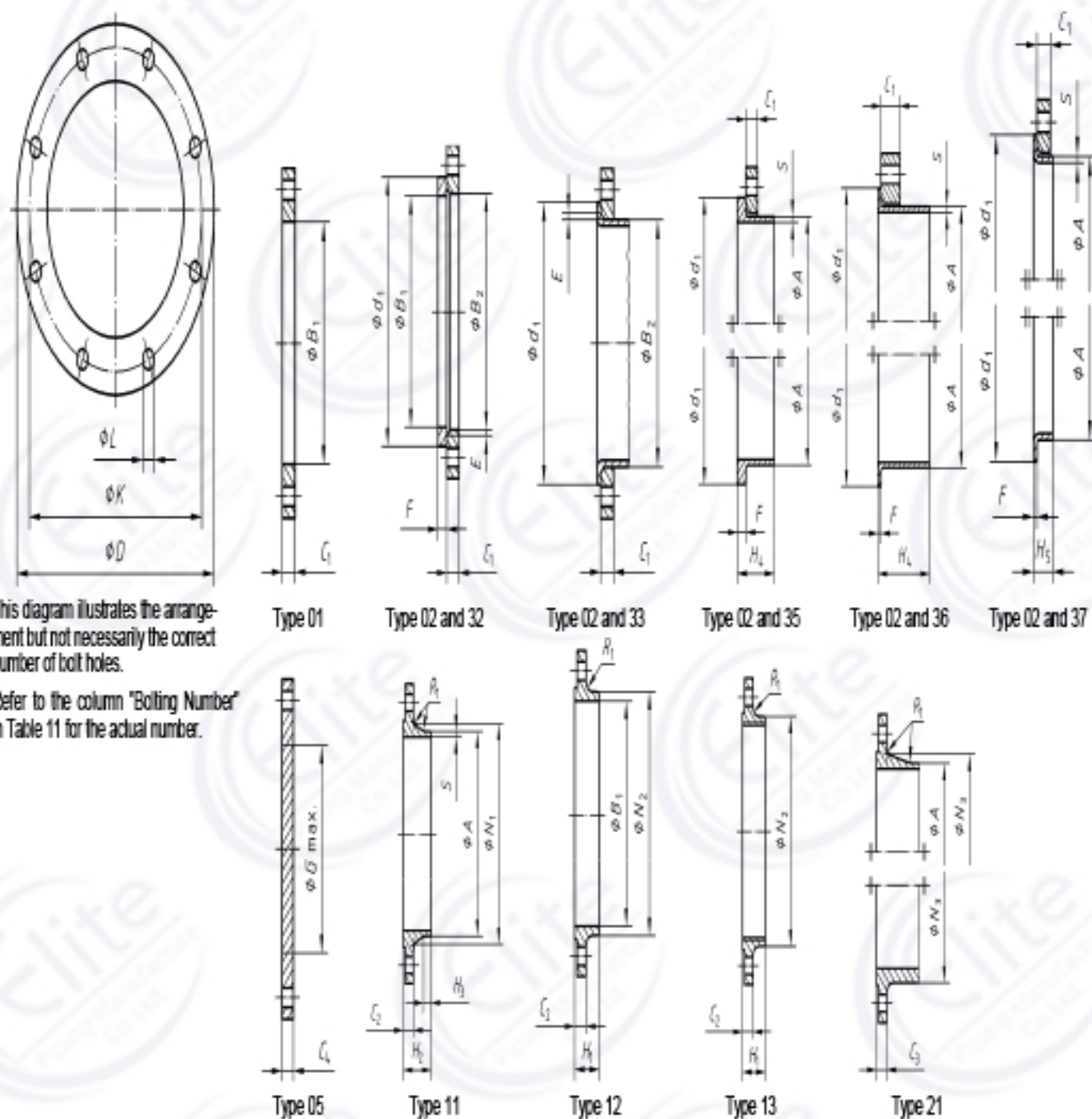

This diagram illustrates the arrangement but not necessarily the correct number of bolt holes.

Refer to the column "Bolting Number" in Table 11 for the actual number.

- NOTE 1 Dimensions  $N_1$ ,  $N_2$  and  $N_3$  are measured at the intersection of the hub draft angle and the back face of the flange.
- NOTE 2 For dimension  $d_1$ , see Table 8.
- NOTE 3 For dimensions  $C_{max}$  refer to NOTE 1 of 5.6.1.
- NOTE 4 Type 33; lapped pipe end without determination of thickness and height.

Figure 6 — Dimensions of PN 6 flanges

Table 11 — Dimensions of PN 6 flanges

Dimensions in millimetres

DN	Mating dimensions					Outside diameter of neck	Bore diameters		Flange thickness			Chamfer	Collar thickness			Diameter of shoulder	Length					Neck diameters			Corner radii	Wall thickness (see 5.6.1)				
	Outside diameter	Diameter of bolt circle	Diameter of bolt hole	Bolting			A	B <sub>1</sub>	B <sub>2</sub>	C <sub>1</sub>	C <sub>2</sub>		C <sub>3</sub>	C <sub>4</sub>	E		F	G <sub>max</sub>	H <sub>1</sub>	H <sub>2</sub>	H <sub>3</sub>	H <sub>4</sub>	H <sub>5</sub>	N <sub>1</sub>			N <sub>2</sub>	N <sub>3</sub>	R <sub>1</sub>	S
				Number	Size																									
Flange type																														
01, 02, 05, 11, 12, 13, 21					11 21 <sup>a</sup> 35-37	01 12 32	02	01 02	11 12 13 21	05	02	32	35	36	37	05	12 13	11	11	35	36	37	11	12 13	21	11 12 13 21	11, 35 to 37			
10	75	50	11	4	M10	17,2	18,0	21	12	12	12	3	10	5	2	2,5	—	20	28	6	28	35	7	26	25	20	4			
15	80	55	11	4	M10	21,3	22,0	25	12	12	12	3	10	5	2	2,5	—	20	30	6	30	38	7	30	30	26	4			
20	90	65	11	4	M10	26,9	27,5	31	14	14	14	4	10	6	2,5	3	—	24	32	6	32	40	8	38	40	34	4			
25	100	75	11	4	M10	33,7	34,5	38	14	14	14	4	10	7	2,5	3	—	24	35	6	35	40	10	42	50	44	4			
32	120	90	14	4	M12	42,4	43,5	46	16	14	14	5	10	8	3	3	—	26	35	6	35	42	12	55	60	54	6			
40	130	100	14	4	M12	48,3	49,5	53	16	14	14	5	10	8	3	3	—	26	38	7	38	45	15	62	70	64	6			
50	140	110	14	4	M12	60,3	61,5	65	16	14	14	5	12	8	3	3	—	28	38	8	38	45	20	74	80	74	6			
65	160	130	14	4	M12	76,1	77,5	81	16	14	14	6	12	8	3	3	55	32	38	9	38	45	20	88	100	94	6			
80	190	150	18	4	M16	88,9	90,5	94	18	16	16	6	12	10	3	4	70	34	42	10	42	50	25	102	110	110	8			
100	210	170	18	4	M16	114,3	116,0	120	18	16	16	6	14	10	4	4	90	40	45	10	45	52	25	130	130	130	8			
125	240	200	18	8	M16	139,7	141,5	145	20	18	18	6	14	10	4	4	115	44	48	10	48	55	25	155	160	160	8			
150	265	225	18	8	M16	168,3	170,5	174	20	18	18	6	14	10	5	4	140	44	48	12	48	55	25	184	185	182	10			
200	320	280	18	8	M16	219,1	221,5	226	22	20	20	6	16	11	5	5	190	44	55	15	55	62	30	236	240	238	10			
250	375	335	18	12	M16	273,0	276,5	281	24	22	22	8	18	12	8		235	44	60	15	60	68	—	290	295	294	12			
300	440	395	22	12	M20	323,9	327,5	333	24	22	22	8	18	12	8		285	44	62	15	62	68	—	342	355	342	12			
350	490	445	22	12	M20	355,6	359,5	365	26	22	22	8	18	13	8		330	—	62	15	62	68	—	385	—	382	12			
400	540	495	22	16	M20	406,4	411,0	416	28	22	22	8	20	14	8		380	—	65	15	65	72	—	438	—	442	12			
450	595	550	22	16	M20	457,0	462,0	467	30	22	24	8	20	15	8	—	425	—	65	15	72	72	—	492	—	494	12			

See Annex A



Table 11 (concluded)

Dimensions in millimetres

DN	Mating dimensions					Outside diameter of neck A	Bore diameters		Flange thickness			Chamfer E	Collar thickness F	Diameter of shoulder G <sub>max</sub>	Length					Neck diameters			Corner radii R <sub>1</sub>	Wall thickness (see 5.6.1) S					
	Outside diameter D	Diameter of bolt circle K	Diameter of bolt hole L	Bolting			B <sub>1</sub>	B <sub>2</sub>	C <sub>1</sub>	C <sub>2</sub> C <sub>3</sub>	C <sub>4</sub>				E	F	G <sub>max</sub>	H <sub>1</sub>	H <sub>2</sub>	H <sub>3</sub>	H <sub>4</sub>	H <sub>5</sub>			N <sub>1</sub>	N <sub>2</sub>	N <sub>3</sub>	R <sub>1</sub>	S
				Number	Size																								
Flange type																													
01, 02, 05, 11, 12, 13, 21					11 21 <sup>a</sup> 35-37	01 12 32	02	01 02	11 12 13 21	05	02	32	35	36	37	05	12 13	11	11	35	36	37	11	12 13	21	11 12 13 21	11, 35 to 37		
500	645	600	22	20	M20	508,0	513,5	519	30	24	24	8	22	16	8	—	475	—	68	15	75	75	—	538	—	544	12		
600	755	705	26	20	M24	610,0	616,5	622	32	30	30	8	22	16	—	—	575	—	70	16	70	—	—	640	—	642	12		
700	860	810	26	24	M24	711,0	b	721	40	30	40	4	—	16	—	—	670	—	76	16	70	—	—	740	—	746	12		
800	975	920	30	24	M27	813,0		824	44	30	44	4	—	16	—	—	—	770	—	76	16	70	—	—	842	—	850	12	
900	1 075	1 020	30	24	M27	914,0		926	48	34	48	4	—	16	—	—	—	860	—	78	16	70	—	—	942	—	950	12	
1 000	1 175	1 120	30	28	M27	1 016,0		1 028	52	38	52	4	—	18	—	—	—	960	—	82	16	70	—	—	1 045	—	1 050	16	
1 200	1 405	1 340	33	32	M30	1 219,0		1 234	60	42	60	5	—	20	—	—	—	1 160	—	104	20	90	—	—	1 248	—	1 264	16	
1 400	1 630	1 560	36	36	M33	1 422,0		—	72	56	68	—	—	—	—	—	—	1 346	—	114	20	—	—	—	1 452	—	1 480	16	
1 600	1 830	1 760	36	40	M33	1 626,0		—	80	63	76	—	—	—	—	—	—	1 546	—	119	20	—	—	—	1 655	—	1 680	16	
1 800	2 045	1 970	39	44	M36	1 829,0		—	88	69	84	—	—	—	—	—	—	1 746	—	133	20	—	—	—	1 855	—	1 878	16	
2 000	2 265	2 180	42	48	M39	2 032,0		—	96	74	92	—	—	—	—	—	—	1 950	—	146	25	—	—	—	2 058	—	2 082	16	
2 200	2 475	2 390	42	52	M39	2 235,0		—	—	—	81	—	—	—	—	—	—	—	—	154	25	—	—	—	2 260	—	—	18	
2 400	2 685	2 600	42	56	M39	2 438,0	—	—	—	87	—	—	—	—	—	—	—	—	168	25	—	—	—	2 462	—	—	18		
2 600	2 905	2 810	48	60	M45	2 620,0	—	—	—	91	—	—	—	—	—	—	—	—	175	25	—	—	—	2 665	—	—	18		
2 800	3 115	3 020	48	64	M45	2 820,0	—	—	—	101	—	—	—	—	—	—	—	—	188	30	—	—	—	2 865	—	—	18		
3 000	3 315	3 220	48	68	M45	3 020,0	—	—	—	102	—	—	—	—	—	—	—	—	192	30	—	—	—	3 068	—	—	18		
3 200	3 525	3 430	48	72	M45	3 220,0	—	—	—	106	—	—	—	—	—	—	—	—	202	30	—	—	—	3 272	—	—	20		
3 400	3 735	3 640	48	76	M45	3 420,0	—	—	—	110	—	—	—	—	—	—	—	—	214	35	—	—	—	3 475	—	—	20		
3 600	3 970	3 860	56	80	M52	3 620,0	—	—	—	124	—	—	—	—	—	—	—	—	229	35	—	—	—	3 678	—	—	20		

See Annex A

<sup>a</sup> For flanges type 21 the outside hub diameter approximately corresponds to the outside pipe diameter.

<sup>b</sup> To be specified by the purchaser.

EN 1092-1:2007 (E)

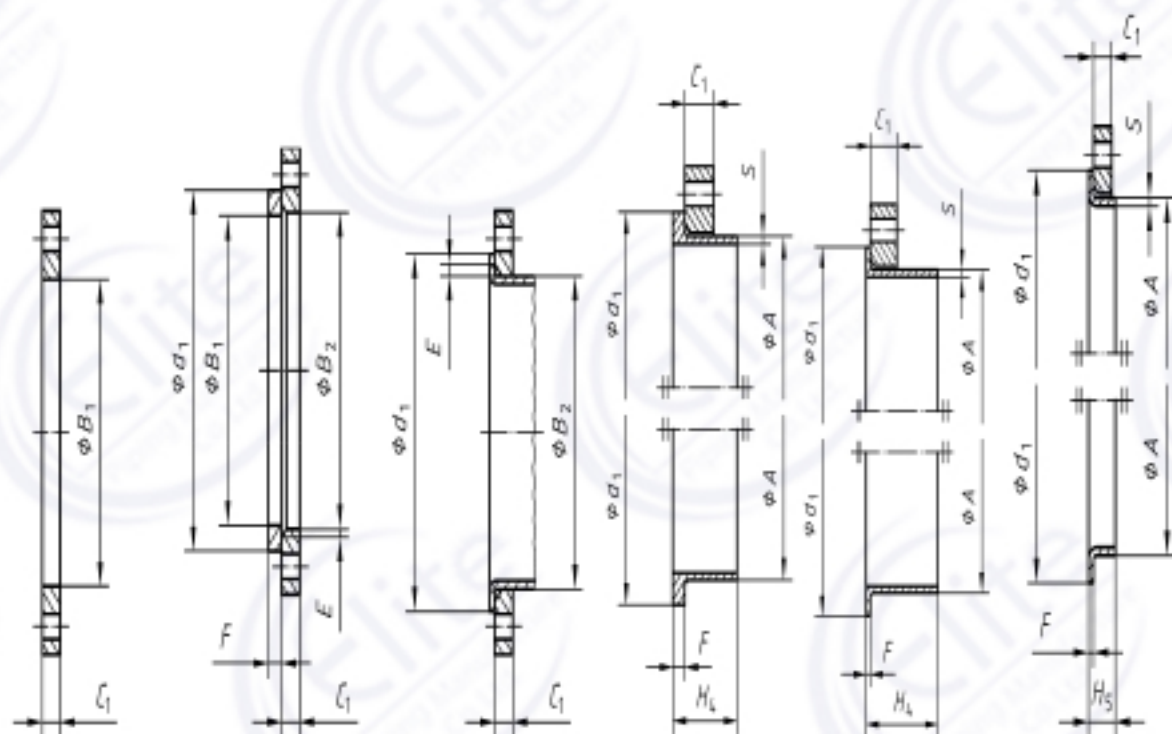
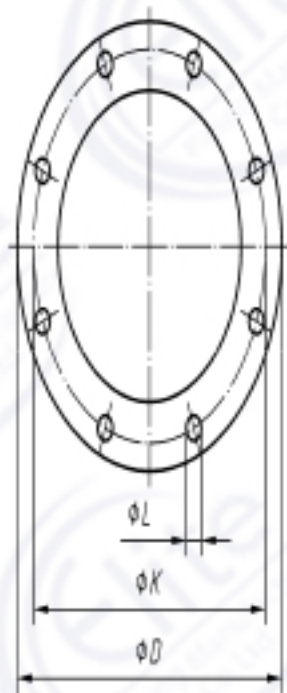

Type 01

Type 02 and 32

Type 02 and 33

Type 02 and 35

Type 02 and 36

Type 02 and 37

This diagram illustrates the arrangement but not necessarily the correct number of bolt holes.

Refer to the column "Bolting Number" in Table 12 for the actual number.

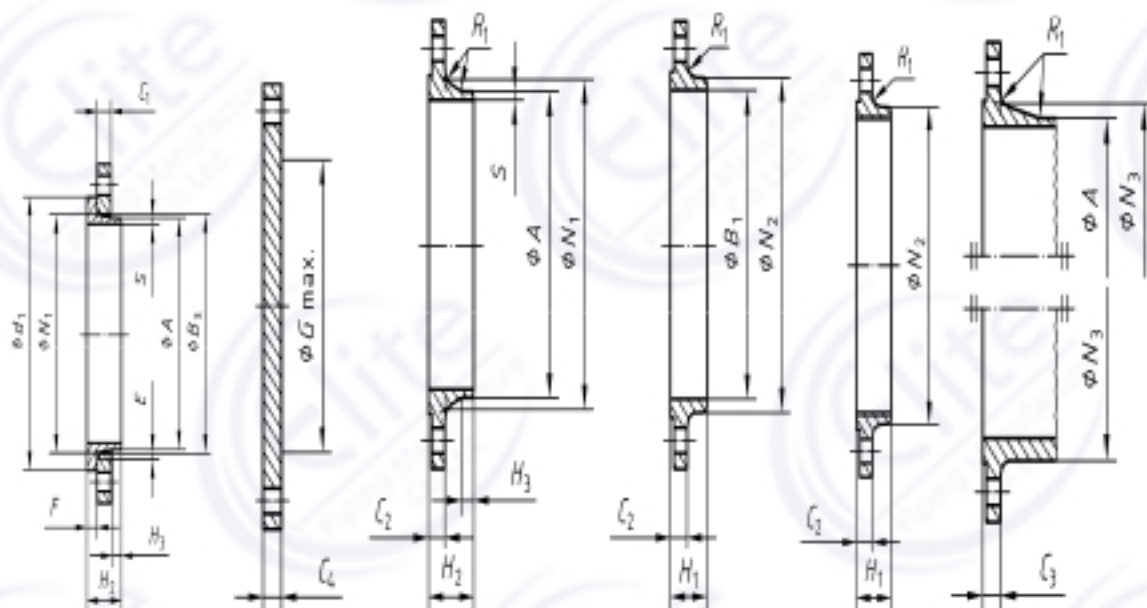

Type 04 and 34

Type 05

Type 11

Type 12

Type 13

Type 21

NOTE 1 Dimensions  $N_1$ ,  $N_2$  and  $N_3$  are measured at the intersection of the hub draft angle and the back face of the flange.

NOTE 2 For dimension  $\phi d_1$ , see Table 8.

NOTE 3 For dimensions  $C_{\text{max}}$  refer to NOTE 1 of 5.6.1.

NOTE 4 Type 33; lapped pipe end without determination of thickness and height.

Figure 7 — Dimensions of PN 10 flanges

Table 12 — Dimensions of PN 10 flanges

Dimensions in millimetres

DN	Mating dimensions						Outside diameter of neck <i>A</i>	Bore diameters			Flange thickness				Chamfer <i>B</i>	Collar thickness				Diameter of shoulder <i>G<sub>min</sub></i>	Length					Neck diameters			Corner radii <i>R<sub>1</sub></i>	Wall thickness (see 5.6.1) <i>S</i>		
	Outside diameter <i>D</i>	Diameter of bolt circle <i>K</i>	Diameter of bolt hole <i>L</i>	Bolting		<i>A<sub>1</sub></i>		<i>A<sub>2</sub></i>	<i>A<sub>3</sub></i>	<i>C<sub>1</sub></i>	<i>C<sub>2</sub></i>	<i>C<sub>3</sub></i>	<i>C<sub>4</sub></i>	<i>F</i>		<i>F</i>	<i>F</i>	<i>F</i>	<i>G<sub>min</sub></i>		<i>H<sub>1</sub></i>	<i>H<sub>2</sub></i>	<i>H<sub>3</sub></i>	<i>H<sub>4</sub></i>	<i>H<sub>5</sub></i>	<i>N<sub>1</sub></i>	<i>N<sub>2</sub></i>	<i>N<sub>3</sub></i>			<i>R<sub>1</sub></i>	<i>S</i>
				Number	Size																											
Flange type																																
01, 02, 04, 05, 11, 12, 13, 21						11 21 <sup>a</sup> 34 <sup>c</sup> 35-37	01 12 32	02	04	01 02 04	11 12 13	21	05	02 04	32 34	35	36	37	05	12 13	11 34 <sup>f</sup>	11 34 <sup>f</sup>	35	36	37	11 34 <sup>f</sup>	12 13	21	11 12 13 21, 34	11, 35 to 37		
10	90	60	14	4	M12	17,2	18,0	21	31	14	16	16	16	3	12	5	2	2,5	—	22	35	6	35	35	7	28	30	28	4	1,8		
15	95	65	14	4	M12	21,3	22,0	25	35	14	16	16	16	3	12	5	2	2,5	—	22	38	6	38	38	7	32	35	32	4	2,0		
20	105	75	14	4	M12	26,9	27,5	31	42	16	18	18	18	4	14	6	2,5	3	—	26	40	6	40	40	8	40	45	40	4	2,3		
25	115	85	14	4	M12	33,7	34,5	38	49	16	18	18	18	4	14	7	2,5	3	—	28	40	6	40	40	10	46	52	50	4	2,6		
32	140	100	18	4	M16	42,4	43,5	47	59	18	18	18	18	5	14	8	3	3	—	30	42	6	42	42	12	56	60	60	6	2,6		
40	150	110	18	4	M16	48,3	49,5	53	67	18	18	18	18	5	14	8	3	3	—	32	45	7	45	45	15	64	70	70	6	2,6		
50	165	125	18	4	M16	60,3	61,5	65	77	20	18	18	18	5	16	8	3	4	—	28	45	8	45	45	20	74	84	84	6	2,9		
65	185	145	18	8	M16	76,1	77,5	81	96	20	18	18	18	6	16	8	3	4	55	32	45	10	45	45	20	92	104	104	6	2,9		
80	200	160	18	8	M16	88,9	90,5	94	108	20	20	20	20	6	16	10	3	4	70	34	50	10	50	50	25	105	118	120	6	3,2		
100	220	180	18	8	M16	114,3	116,0	120	134	22	20	20	20	6	18	10	4	4	90	40	52	12	52	52	25	131	140	140	8	3,6		
125	250	210	18	8	M16	139,7	141,5	145	162	22	22	22	22	6	18	10	4	4	115	44	55	12	55	55	25	156	168	170	8	4,0		
150	285	240	22	8	M20	168,3	170,5	174	188	24	22	22	22	6	20	10	4	4	140	44	55	12	55	55	25	184	195	190	10	4,5		
200	340	295	22	8	M20	219,1	221,5	226	240	24	24	24	24	6	20	11	5	4	190	44	62	16	62	62	30	234	246	246	10	6,3		
250	395	350	22	12	M20	273,0	276,5	281	294	26	26	26	26	8	22	12	8	—	235	46	68	16	68	68	—	292	298	298	12	6,3		
300	445	400	22	12	M20	323,9	327,5	333	348	26	26	26	26	8	22	12	8	—	285	46	68	16	68	68	—	342	350	348	12	7,1		
350	505	460	22	16	M20	355,6	359,5	365	400	30	26	26	26	8	22	13	8	—	330	53	68	16	68	68	—	385	400	408	12	7,1		
400	565	515	26	16	M24	406,4	411,0	416	450	32	26	26	26	8	24	14	8	—	380	57	72	16	72	72	—	440	456	456	12	7,1		
450	615	565	26	20	M24	457,0	462,0	467	498	36	28	28	28	8	24	15	—	—	425	63	72	16	72	—	—	488	502	502	12	7,1		
500	670	620	26	20	M24	508,0	513,5	519	550	38	28	28	28	8	26	16	—	—	475	67	75	16	75	—	—	542	559	559	12	7,1		
600	780	725	30	20	M27	610,0	616,5	622	650	42	30	34	34	8	26	18	—	—	575	75	82	18	80	—	—	642	658	658	12	—		
700	895	840	30	24	M27	711,0		721	—	50	35			38	8	—	20	—	670	—	85	18	80	—	—	746	—	772	12	—		
800	1 015	950	33	24	M30	813,0		824	—	56	38			48	8	—	20	—	770	—	96	18	90	—	—	850	—	876	12	—		
900	1 115	1 050	33	28	M30	914,0		926	—	62	38			50	8	—	22	—	860	—	99	20	95	—	—	950	—	976	12	—		
1 000	1 230	1 160	36	28	M33	1 016,0		1 028	—	70	44			54	8	—	24	—	960	—	105	20	95	—	—	1 052	—	1 080	16	—		
1 200	1 455	1 380	39	32	M36	1 219,0		1 234	—	83	55			66	8	—	26	—	1 160	—	132	25	115	—	—	1 256	—	1 292	16	—		
1 400	1 675	1 590	42	36	M39	1 422,0															143	25				1 460	—	1 496	16	—		
1 600	1 915	1 820	48	40	M45	1 626,0															159	25				1 666	—	1 712	16	—		
1 800	2 115	2 020	48	44	M45	1 829,0															175	30				1 868	—	1 910	16	—		

See Annex A

Table 12 (concluded)

Dimensions in millimetres

DN	Mating dimensions					Outside diameter of neck A	Bore diameters			Flange thickness				Chamfer E	Collar thickness			Diameter of shoulder G <sub>max</sub>	Length					Neck diameters			Corner radii R <sub>1</sub>	Wall thickness (see 5.6.1) S				
	Outside diameter D	Diameter of bolt circle K	Diameter of bolt hole L	Bolting			B <sub>1</sub>	B <sub>2</sub>	B <sub>3</sub>	C <sub>1</sub>	C <sub>2</sub>	C <sub>3</sub>	C <sub>4</sub>		F	G <sub>max</sub>	H <sub>1</sub>		H <sub>2</sub>	H <sub>3</sub>	H <sub>4</sub>	H <sub>5</sub>	N <sub>1</sub>	N <sub>2</sub>	N <sub>3</sub>	R <sub>1</sub>			S			
				Number	Size																											
	01, 02, 04, 05, 11, 12, 13, 21					11 21 <sup>a</sup> 34 <sup>c</sup> 35-37	01 12 32	02	04	01 02 04	11 12 13	21 05	02 04	32 34	35	36	37	05	12 13	11 34	11 34	35	36	37	11 34	12 13	21	11 12 13 21, 34	34	11, 35 to 37		
2 000	2 325	2 230	48	48	M45	2 032,0	—	—	—				90	—	—	—	—	—	—	—	—	—	—	—	—	—	—	—	—	—	—	See Annex A
2 200	2 550	2 440	56	52	M52	2 235,0	—	—	—				100	—	—	—	—	—	—	—	—	—	—	—	—	—	—	—	—	—		
2 400	2 760	2 650	56	56	M52	2 438,0	—	—	—				110	—	—	—	—	—	—	—	—	—	—	—	—	—	—	—	—	—		
2 600	2 960	2 850	56	60	M52	2 620,0	—	—	—				110	—	—	—	—	—	—	—	—	—	—	—	—	—	—	—	—	—		
2 800	3 180	3 070	56	64	M52	2 820,0	—	—	—				124	—	—	—	—	—	—	—	—	—	—	—	—	—	—	—	—	—		
3 000	3 405	3 290	62	68	M56	3 020,0	—	—	—				132	—	—	—	—	—	—	—	—	—	—	—	—	—	—	—	—	—		

<sup>a</sup> For flanges type 21 the outside hub diameter approximately corresponds to the outside pipe diameter.  
<sup>b</sup> To be specified by the purchaser.  
<sup>c</sup> Use is limited up to DN 600.

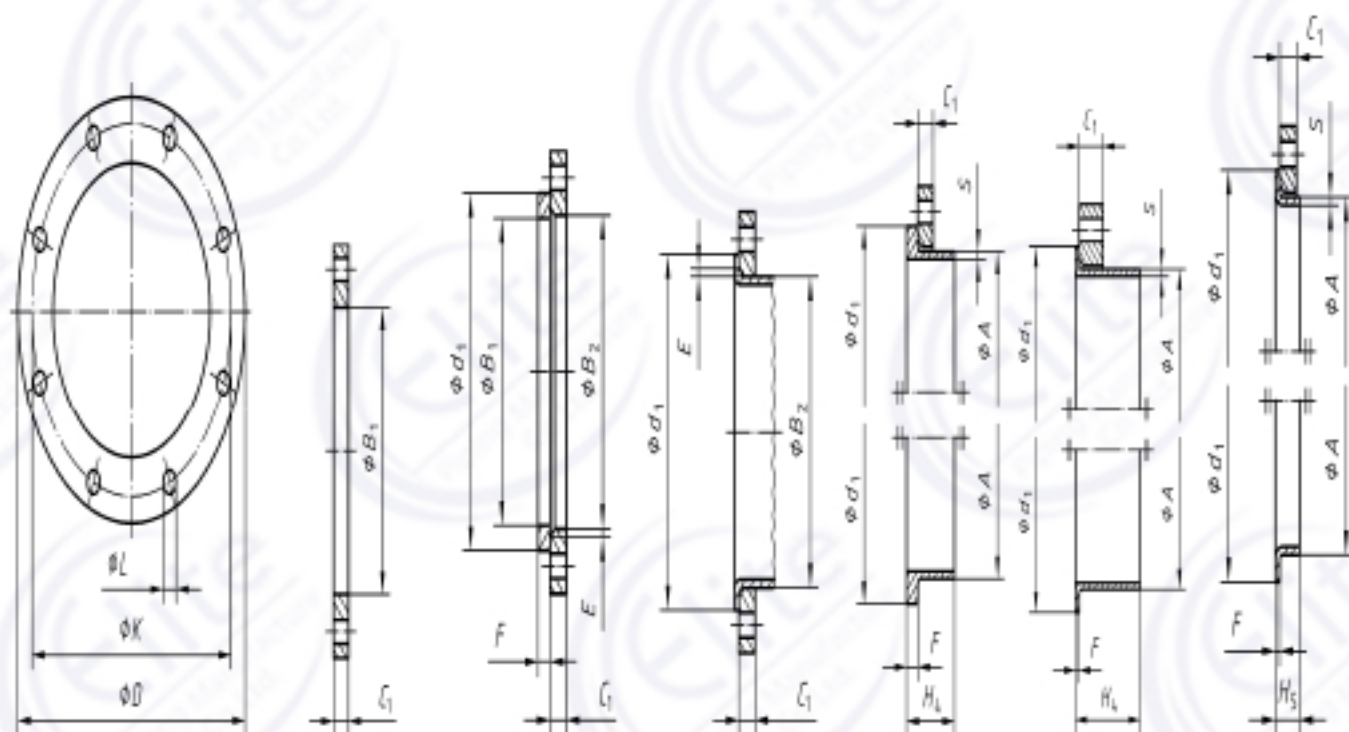

Type 01

Type 02 and 32

Type 02 and 33

Type 02 and 35

Type 02 and 36

Type 02 and 37

This diagram illustrates the arrangement but not necessarily the correct number of bolt holes.

Refer to the column "Bolting Number" in Table 13 for the actual number.

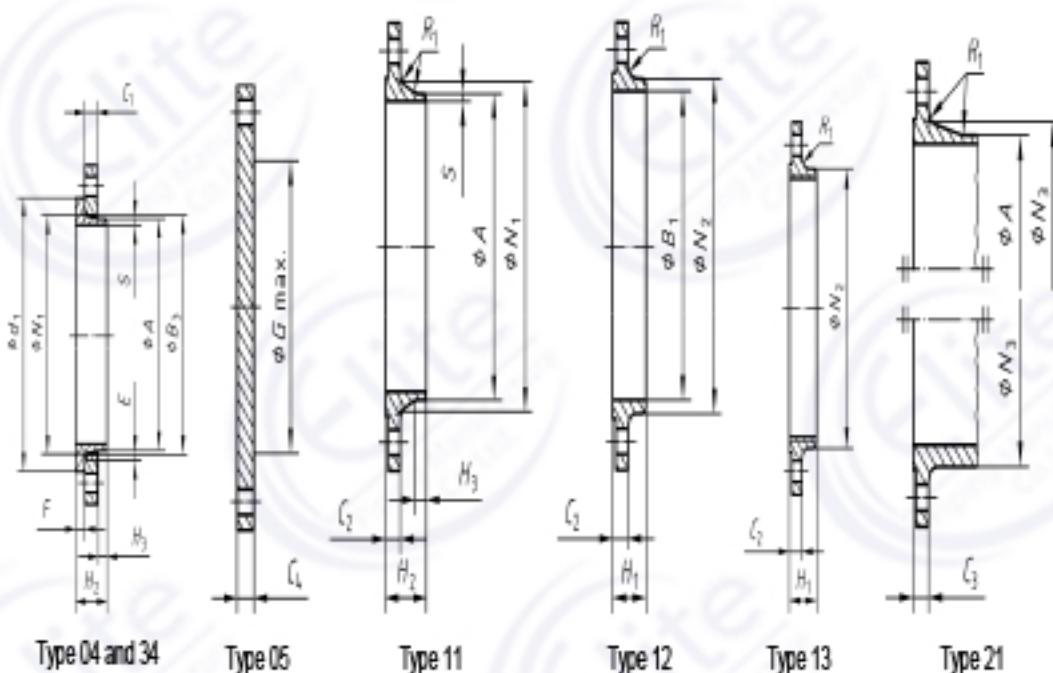

Type 04 and 34

Type 05

Type 11

Type 12

Type 13

Type 21

NOTE 1 Dimensions  $H_1$ ,  $N_2$  and  $N_3$  are measured at the intersection of the hub draft angle and the back face of the flange.

NOTE 2 For dimension  $d_1$ , see Table 8.

NOTE 3 For dimensions  $C_{max}$  refer to NOTE 1 of 5.6.1.

NOTE 4 Type 33; lapped pipe end without determination of thickness and height.

Figure 8 — Dimensions of PN 16 flanges

Table 13 — Dimensions of PN 16 flanges

Dimensions in millimetres

DN	Mating dimensions					Outside diameter of neck <i>A</i>	Bore diameters				Flange thickness				Chamfer <i>E</i>	Collar thickness			Diameter of shoulder <i>G<sub>max</sub></i>	Length					Neck diameters			Corner radii <i>R<sub>1</sub></i>	Wall thickness (see 5.6.1) <i>S</i>	
	Outside diameter <i>D</i>	Diameter of bolt circle <i>K</i>	Diameter of bolt hole <i>L</i>	Bolting			<i>B<sub>1</sub></i>	<i>B<sub>2</sub></i>	<i>B<sub>3</sub></i>	<i>C<sub>1</sub></i>	<i>C<sub>2</sub></i>	<i>C<sub>3</sub></i>	<i>C<sub>4</sub></i>	<i>F</i>		<i>F</i>	<i>F</i>	<i>H<sub>1</sub></i>		<i>H<sub>2</sub></i>	<i>H<sub>3</sub></i>	<i>H<sub>4</sub></i>	<i>H<sub>5</sub></i>	<i>N<sub>1</sub></i>	<i>N<sub>2</sub></i>	<i>N<sub>3</sub></i>	<i>R<sub>1</sub></i>			
				Number	Size																									
Flange type																														
01, 02, 04, 05, 11, 12, 13, 21					11 21 <sup>a</sup> 34 <sup>d</sup> 35-37	01 12 32	02	04	01 02 04	11 12 13	21 05	02 04	32 34	35	36	37	05	12 13	11 34 <sup>c</sup>	11 34 c	35	36	37	11 34 <sup>e</sup>	12 13	21	11 12 13 21, 34	34	11, 35 to 37	
10	90	60	14	4	M12	17,2	18,0	21	31	14	16	16	16	3	12	5	2	2,5	—	22	35	6	35	35	7	28	30	28	4	1,8
15	95	65	14	4	M12	21,3	22,0	25	35	14	16	16	16	3	12	5	2	2,5	—	22	38	6	38	38	7	32	35	32	4	2,0
20	105	75	14	4	M12	26,9	27,5	31	42	16	18	18	18	4	14	6	2,5	3	—	26	40	6	40	40	8	40	45	40	4	2,3
25	115	85	14	4	M12	33,7	34,5	38	49	16	18	18	18	4	14	7	2,5	3	—	28	40	6	40	40	10	46	52	50	4	2,6
32	140	100	18	4	M16	42,4	43,5	47	59	18	18	18	18	5	14	8	3	3	—	30	42	6	42	42	12	56	60	60	6	2,6
40	150	110	18	4	M16	48,3	49,5	53	67	18	18	18	18	5	14	8	3	3	—	32	45	7	45	45	15	64	70	70	6	2,6
50	165	125	18	4	M16	60,3	61,5	65	77	20	18	18	18	5	16	8	3	4	—	28	45	8	45	45	20	74	84	84	6	2,9
65	185	145	18	8 <sup>b</sup>	M16	76,1	77,5	81	96	20	18	18	18	6	16	8	3	4	55	32	45	10	45	45	20	92	104	104	6	2,9
80	200	160	18	8	M16	88,9	90,5	94	108	20	20	20	20	6	16	10	3	4	70	34	50	10	50	50	25	105	118	120	6	3,2
100	220	180	18	8	M16	114,3	116,0	120	134	22	20	20	20	6	18	10	4	4	90	40	52	12	52	52	25	131	140	140	8	3,6
125	250	210	18	8	M16	139,7	141,5	145	162	22	22	22	22	6	18	10	4	4	115	44	55	12	55	55	25	156	168	170	8	4,0
150	285	240	22	8	M20	168,3	170,5	174	188	24	22	22	22	6	20	10	5	5	140	44	55	12	55	55	25	184	195	190	10	4,5
200	340	295	22	12	M20	219,1	221,5	226	240	26	24	24	24	6	20	11	6	6	190	44	62	16	62	62	30	235	246	246	10	6,3
250	405	355	26	12	M24	273,0	276,5	281	294	28	26	26	26	8	22	12	10	—	235	46	70	16	70	68	—	292	298	296	12	6,3
300	460	410	26	12	M24	323,9	327,5	333	348	32	28	28	28	8	24	14	10	—	285	46	78	16	78	68	—	344	350	350	12	7,1
350	520	470	26	16	M24	355,6	359,0	365	400	35	30	30	30	8	26	18	10	—	330	57	82	16	82	68	—	390	400	410	12	8,0

See Annex A

400	580	525	30	16	M27	406,4	411,0	416	454	38	32	32	32	8	28	20	10	—	380	63	85	16	85	72	445	456	458	12	8,0
450	640	585	30	20	M27	457,0	462,0	467	500	42	34	40	40	8	30	22	—	—	425	68	83	16	87	—	490	502	516	12	8,0
500	715	650	33	20	M30	508,0	513,5	519	556	46	36	44	44	8	32	22	—	—	475	73	84	16	90	—	548	559	576	12	8,0
600	840	770	36	20	M33	610,0	616,5	622	660	55	40	54	54	8	32	24	—	—	575	83	88	18	95	—	670	658	690	12	8,8
700	910	840	36	24	M33	711,0	c	721	—	63	40	—	58	8	—	26	—	—	670	83	104	18	100	—	755	760	780	12	—
800	1 025	950	39	24	M36	813,0		824	—	74	41	—	62	8	—	28	—	—	770	90	108	20	105	—	855	864	882	12	—
900	1 125	1 050	39	28	M36	914,0		926	—	82	48	—	64	8	—	30	—	—	860	94	118	20	110	—	955	968	982	12	—
1 000	1 255	1 170	42	28	M39	1 016,0		1 030	—	90	58	—	68	8	—	35	—	—	960	100	137	22	120	—	1 058	1 072	1 076	16	—
1 200	1 485	1 390	48	32	M45	1 219,0	—	—	—	—	78	d	—	—	—	—	—	—	1 160	—	160	30	—	—	1 262	—	1 282	16	—
1 400	1 685	1 590	48	36	M45	1 422,0	—	—	—	—	84	—	—	—	—	—	—	—	1 346	—	177	30	—	—	1 465	—	1 482	16	—
1 600	1 930	1 820	56	40	M52	1 626,0	—	—	—	c	102	—	—	—	—	—	—	—	1 546	—	204	35	—	—	1 668	—	1 696	16	—
1 800	2 130	2 020	56	44	M52	1 829,0	—	—	—	—	110	—	—	—	—	—	—	—	1 746	—	218	35	—	—	1 870	—	1 896	16	—
2 000	2 345	2 230	62	48	M56	2 032,0	—	—	—	—	124	—	—	—	—	—	—	—	1 950	—	238	40	—	—	2 072	—	2 100	16	—

<sup>a</sup> For flanges type 21 the outside hub diameter approximately corresponds to the outside pipe diameter.

<sup>b</sup> According to EN 1092-2 (Cast iron flanges) and EN 1092-3 (Copper alloy flanges), the flanges in this DN and PN may be supplied with 4 holes. Where steel flanges are required with 4 holes, these may be supplied by agreement between flange manufacturer and purchaser.

<sup>c</sup> To be specified by the purchaser.

<sup>d</sup> Use is limited up to DN 600.

EN 1092-1:2007 (E)

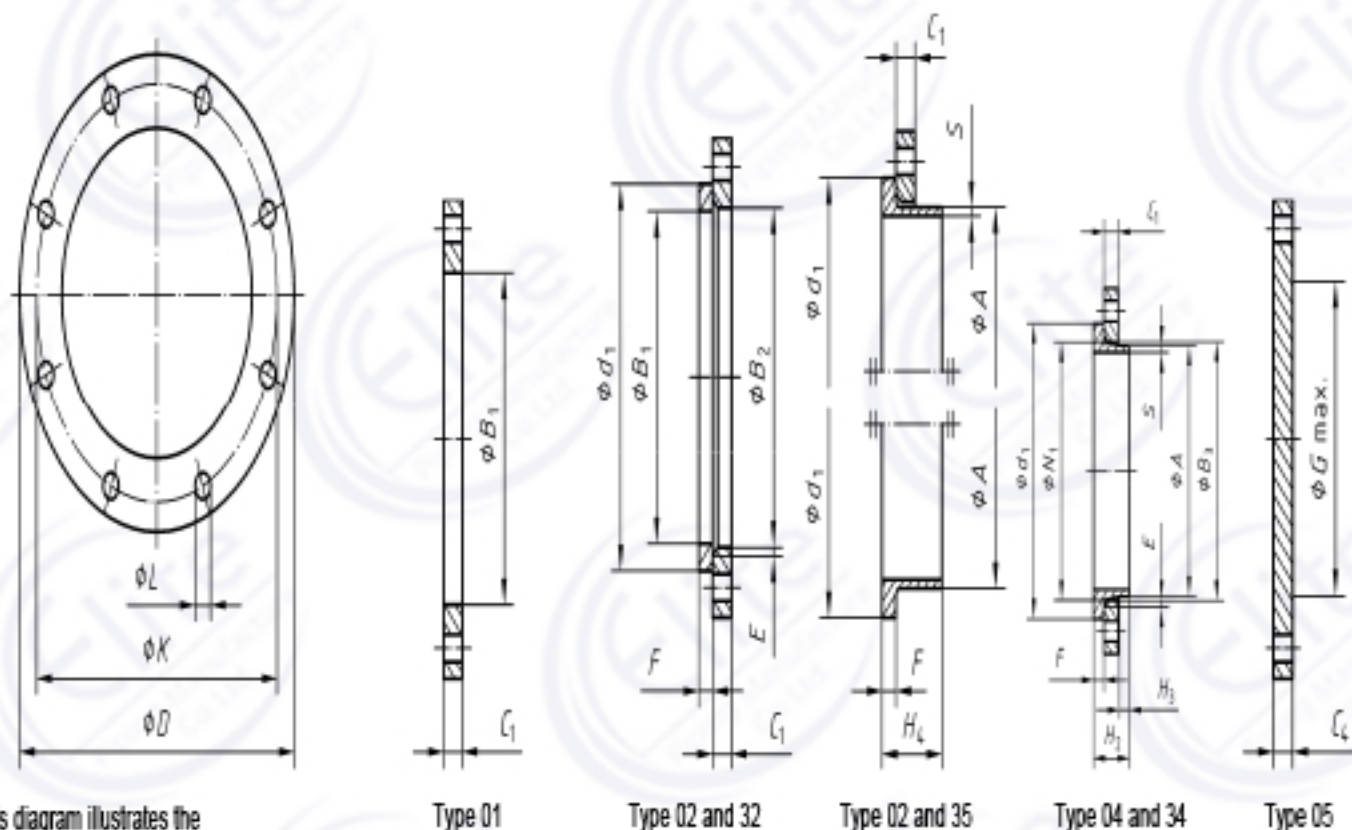

This diagram illustrates the arrangement but not necessarily the correct number of bolt holes.

Refer to the column "Bolting Number" in Table 14 for the actual number.

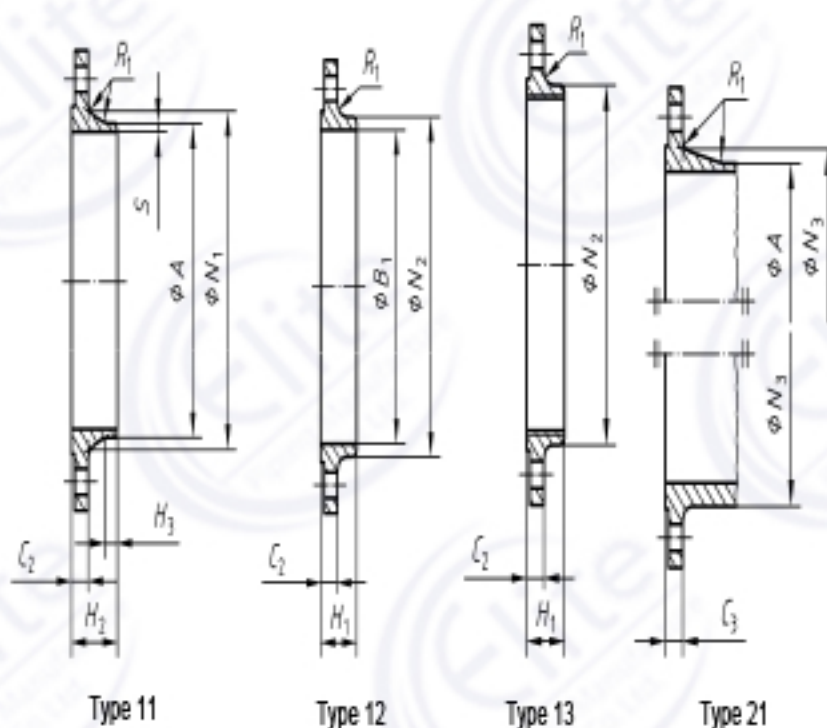

- NOTE 1 Dimensions  $N_1$ ,  $N_2$  and  $N_3$  are measured at the intersection of the hub draft angle and the back face of the flange.  
 NOTE 2 For dimension  $d_1$ , see Table 8.  
 NOTE 3 For dimensions  $C_{max}$  refer to NOTE 1 of 5.6.1.

Figure 9 — Dimensions of PN 25 flanges



Table 14 — Dimensions of PN 25 flanges

Dimensions in millimetres

DN	Mating dimensions						Outside diameter of neck A	Bore diameters			Flange thickness				Chamfer E	Collar thickness F	Diameter of shoulder G <sub>max</sub>	Length				Neck diameters			Corner radii R <sub>1</sub>	Wall thickness (see 5.6.1) S
	Outside diameter D	Diameter of bolt circle K	Diameter of bolt hole L	Bolting		B <sub>1</sub>		B <sub>2</sub>	B <sub>3</sub>	C <sub>1</sub>	C <sub>2</sub>	C <sub>3</sub>	C <sub>4</sub>	H <sub>1</sub>				H <sub>2</sub>	H <sub>3</sub>	H <sub>4</sub>	N <sub>1</sub>	N <sub>2</sub>	N <sub>3</sub>			
				Number	Size																					
	Flange type																									
	01, 02, 04, 05, 11, 12, 13, 21						11 21 <sup>a</sup> 34 <sup>c</sup> 35	01 12 02	02 04	01 11 02 12 21 05	02 04	32 34 35	05	12 13	11 34 <sup>c</sup> 34 <sup>c</sup>	35	11 34	12 13	21	11 12 13 21, 34	34	11, 35				
10	90	60	14	4	M12	17,2	18,0	21	31	14	16	16	16	3	12	5	—	22	35	6	35	28	30	28	4	1,8
15	95	65	14	4	M12	21,3	22,0	25	35	14	16	16	16	3	12	5	—	22	38	6	38	32	35	32	4	2,0
20	105	75	14	4	M12	26,9	27,5	31	42	16	18	18	18	4	14	6	—	26	40	6	40	40	45	40	4	2,3
25	115	85	14	4	M12	33,7	34,5	38	49	16	18	18	18	4	14	7	—	28	40	6	40	46	52	50	4	2,6
32	140	100	18	4	M16	42,4	43,5	47	59	18	18	18	18	5	14	8	—	30	42	6	42	56	60	60	6	2,6
40	150	110	18	4	M16	48,3	49,5	53	67	18	18	18	18	5	14	8	—	32	45	7	45	64	70	70	6	2,6
50	165	125	18	4	M16	60,3	61,5	65	77	20	20	20	20	5	16	10	—	34	48	8	48	75	84	84	6	2,9
65	185	145	18	8	M16	76,1	77,5	81	96	22	22	22	22	6	16	11	55	38	52	10	52	90	104	104	6	2,9
80	200	160	18	8	M16	88,9	90,5	94	114	24	24	24	24	6	18	12	70	40	58	12	58	105	118	120	8	3,2
100	235	190	22	8	M20	114,3	116,0	120	138	26	24	24	24	6	20	14	90	44	65	12	65	134	145	142	8	3,6
125	270	220	26	8	M24	139,7	141,5	145	166	28	26	26	26	6	22	16	115	48	68	12	68	162	170	162	8	4,0
150	300	250	26	8	M24	168,3	170,5	174	194	30	28	28	28	6	24	18	140	52	75	12	75	192	200	192	10	4,5
200	360	310	26	12	M24	219,1	221,5	226	250	32	30	30	30	6	26	18	190	52	80	16	80	244	256	252	10	6,3
250	425	370	30	12	M27	273,0	276,5	281	302	35	32	32	32	8	26	18	235	60	88	18	88	298	310	304	12	7,1
300	485	430	30	16	M27	323,9	327,5	333	356	38	34	34	34	8	28	20	285	67	92	18	92	352	364	364	12	8,0
350	555	490	33	16	M30	355,6	359,5	365	408	42	38	38	38	8	32	22	332	72	100	20	100	398	418	418	12	8,0
400	620	550	36	16	M33	406,4	411,0	416	462	48	40	40	40	8	34	24	380	78	110	20	110	452	472	472	12	8,8
450	670	600	36	20	M33	457,0	462,0	467	510	54	46	46	50	8	36	26	425	84	110	20	110	500	520	520	12	8,8
500	730	660	36	20	M33	508,0	513,5	519	568	58	48	48	51	8	38	28	475	90	125	20	125	558	580	580	12	10,0
600	845	770	39	20	M36	610,0	616,5	622	670	68	48	58	66	8	40	30	575	100	125	20	115	660	684	684	12	11,0
700	960	875	42	24	M39	711,0		721	—	85	50			8	—	30	—	—	129	20	125	760	—	780	12	—
800	1 085	990	48	24	M45	813,0	<sup>b</sup>	824	—	95	53	<sup>b</sup>	<sup>b</sup>	8	—	35	—	—	138	22	135	864	—	882	12	—
900	1 185	1 090	48	28	M45	914,0		—	—	<sup>b</sup>	57			—	—	—	—	—	148	24	—	968	—	982	12	—
1 000	1 320	1 210	56	28	M52	1 016,0		—	—	<sup>b</sup>	63			—	—	—	—	—	160	24	—	1 070	—	1 086	16	—
1 200																										
1 400																										
1 600																										
1 800																										
2 000																										

See Annex A

<sup>a</sup> For flanges type 21 the outside hub diameter approximately corresponds to the outside pipe diameter.

<sup>b</sup> To be specified by the purchaser.

<sup>c</sup> Use is limited up to DN 500.

<sup>d</sup> Only mating dimensions fixed, see Annex J.

EN 1092-1:2007 (E)

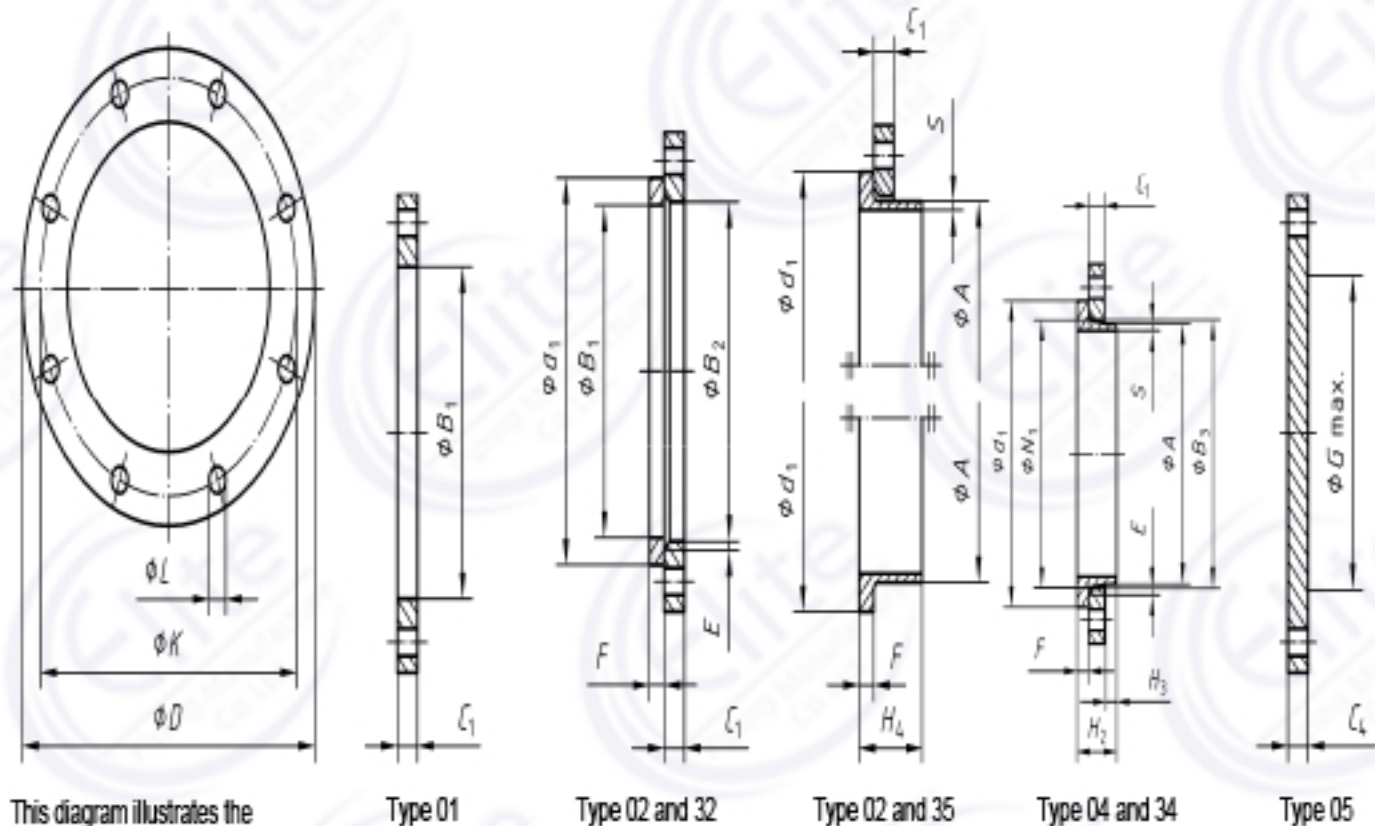

This diagram illustrates the arrangement but not necessarily the correct number of bolt holes. Refer to the column "Bolting Number" in Table 15 for the actual number.

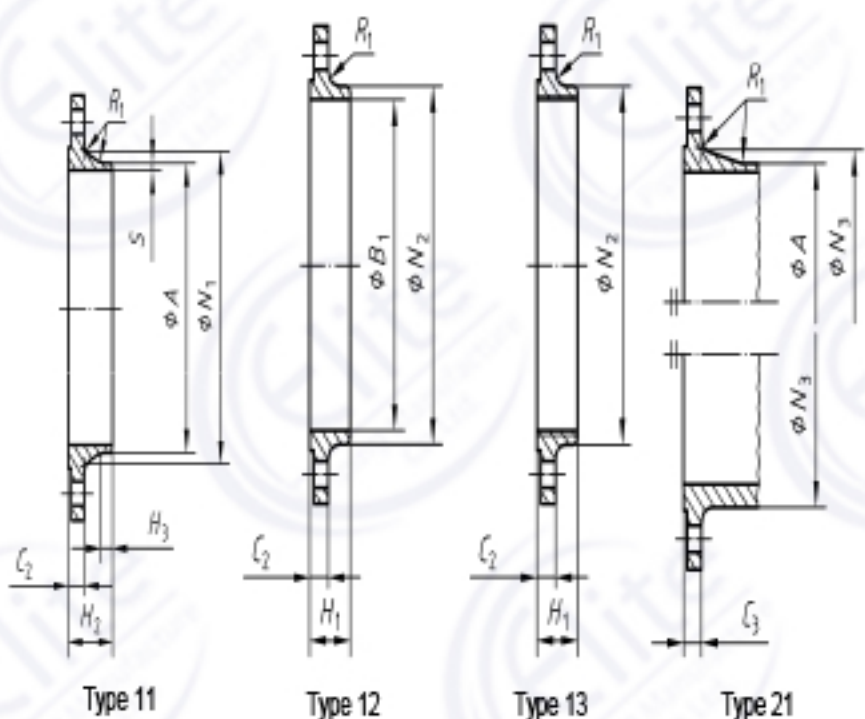

- NOTE 1 Dimensions  $N_1, N_2$  and  $N_3$  are measured at the intersection of the hub draft angle and the back face of the flange.
- NOTE 2 For dimension  $d_1$ , see Table 8.
- NOTE 3 For dimensions  $C_{\text{max}}$  refer to NOTE 1 of 5.6.1.

Figure 10 — Dimensions of PN 40 flanges

Table 15 — Dimensions of PN 40 flanges

Dimensions in millimetres

DN	Mating dimensions					Outside diameter of neck	Bore diameters			Flange thickness				Chamfer	Collar thickness	Diameter of shoulder	Length				Neck diameters			Corner radii	Neck thickness (see 5.6.1)	
	Outside diameter	Diameter of bolt circle	Diameter of bolt hole	Bolting			A	B <sub>1</sub>	B <sub>2</sub>	B <sub>3</sub>	C <sub>1</sub>	C <sub>2</sub>	C <sub>3</sub>				C <sub>4</sub>	E	F	C <sub>min</sub>	H <sub>1</sub>	H <sub>2</sub>	H <sub>3</sub>			H <sub>4</sub>
				Number	Size	H <sub>1</sub>								H <sub>2</sub>	H <sub>3</sub>	H <sub>4</sub>								N <sub>1</sub>	N <sub>2</sub>	
	Flange type																									
01, 02, 04, 05, 11, 12, 13, 21					11 21 <sup>a</sup> 34 <sup>c</sup>	01 12 32	02	04	01 02 04	11 12 13	21	05	02 04	32 34 <sup>c</sup>	35	05	12 13	11 34 <sup>c</sup>	11 34 <sup>c</sup>	35	11 34	12 13	21	11 12 13 21	34 <sup>c</sup>	11, 35
10	90	60	14	4	M12	17,2	18,0	21	31	14	16	16	3	12	5	—	22	35	6	35	28	30	28	4	1,8	
15	95	65	14	4	M12	21,3	22,0	25	35	14	16	16	3	12	5	—	22	38	6	38	32	35	32	4	2,0	
20	105	75	14	4	M12	26,9	27,5	31	42	16	18	18	4	14	6	—	26	40	6	40	40	45	40	4	2,3	
25	115	85	14	4	M12	33,7	34,5	38	49	16	18	18	4	14	7	—	28	40	6	40	46	52	50	4	2,6	
32	140	100	18	4	M16	42,4	43,5	47	59	18	18	18	5	14	8	—	30	42	6	42	56	60	60	6	2,6	
40	150	110	18	4	M16	48,3	49,5	53	67	18	18	18	5	14	8	—	32	45	7	45	64	70	70	6	2,6	
50	165	125	18	4	M16	60,3	61,5	65	77	20	20	20	5	16	10	—	34	48	8	48	75	84	84	6	2,9	
65	185	145	18	8	M16	76,1	77,5	81	96	22	22	22	6	16	11	55	38	52	10	52	90	104	104	6	2,9	
80	200	160	18	8	M16	88,9	90,5	94	114	24	24	24	6	18	12	70	40	58	12	58	105	118	120	8	3,2	
100	235	190	22	8	M20	114,3	116,0	120	138	26	24	24	6	20	14	90	44	65	12	65	134	145	142	8	3,6	
125	270	220	26	8	M24	139,7	141,5	145	166	28	26	26	6	22	16	115	48	68	12	68	162	170	162	8	4,0	
150	300	250	26	8	M24	168,3	170,5	174	194	30	28	28	6	24	18	140	52	75	12	75	192	200	192	10	4,5	
200	375	320	30	12	M27	219,1	221,5	226	250	36	34	36	6	28	20	190	52	88	16	88	244	260	254	10	6,3	
250	450	385	33	12	M30	273,0	276,5	281	312	42	38	38	8	30	22	235	60	105	18	105	306	312	312	12	7,1	
300	515	450	33	16	M30	323,9	327,5	333	368	52	42	42	8	34	25	265	67	115	18	115	362	380	378	12	8,0	
350	580	510	36	16	M33	355,6	359,5	365	418	58	46	46	8	36	28	330	72	125	20	125	408	424	432	12	8,8	
400	660	585	39	16	M36	406,4	411,0	416	472	65	50	50	8	42	32	380	78	135	20	135	462	478	498	12	11,0	
450	685	610	39	20	M36	457,0	462,0	467	510	d	57	57	8	46	—	425	84	135	20	—	500	522	522	12	12,5	
500	755	670	42	20	M39	508,0	513,5	519	572		57	57	8	50	—	475	90	140	20	—	562	576	576	12	14,2	
600	860	795	48	20	M45	610,0	616,5	622	676		72	72	8	54	—	575	100	150	20	—	686	696	696	12	16,0	
700																										
800																										
900																										
1 000																										
1 200																										
1 400																										
1 600																										

See Annex A

<sup>a</sup> For flanges type 21 the outside hub diameter approximately corresponds to the outside pipe diameter.

<sup>b</sup> Only mating dimensions fixed, see Annex J.

<sup>c</sup> Use is limited up to DN 600.

<sup>d</sup> To be specified by the purchaser.

EN 1092-1:2007 (E)

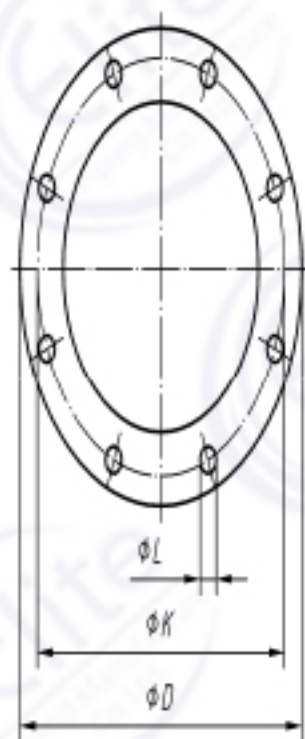

This diagram illustrates the arrangement but not necessarily the correct number of bolt holes.

Refer to the column "Bolting Number" in Table 16 for the actual number.

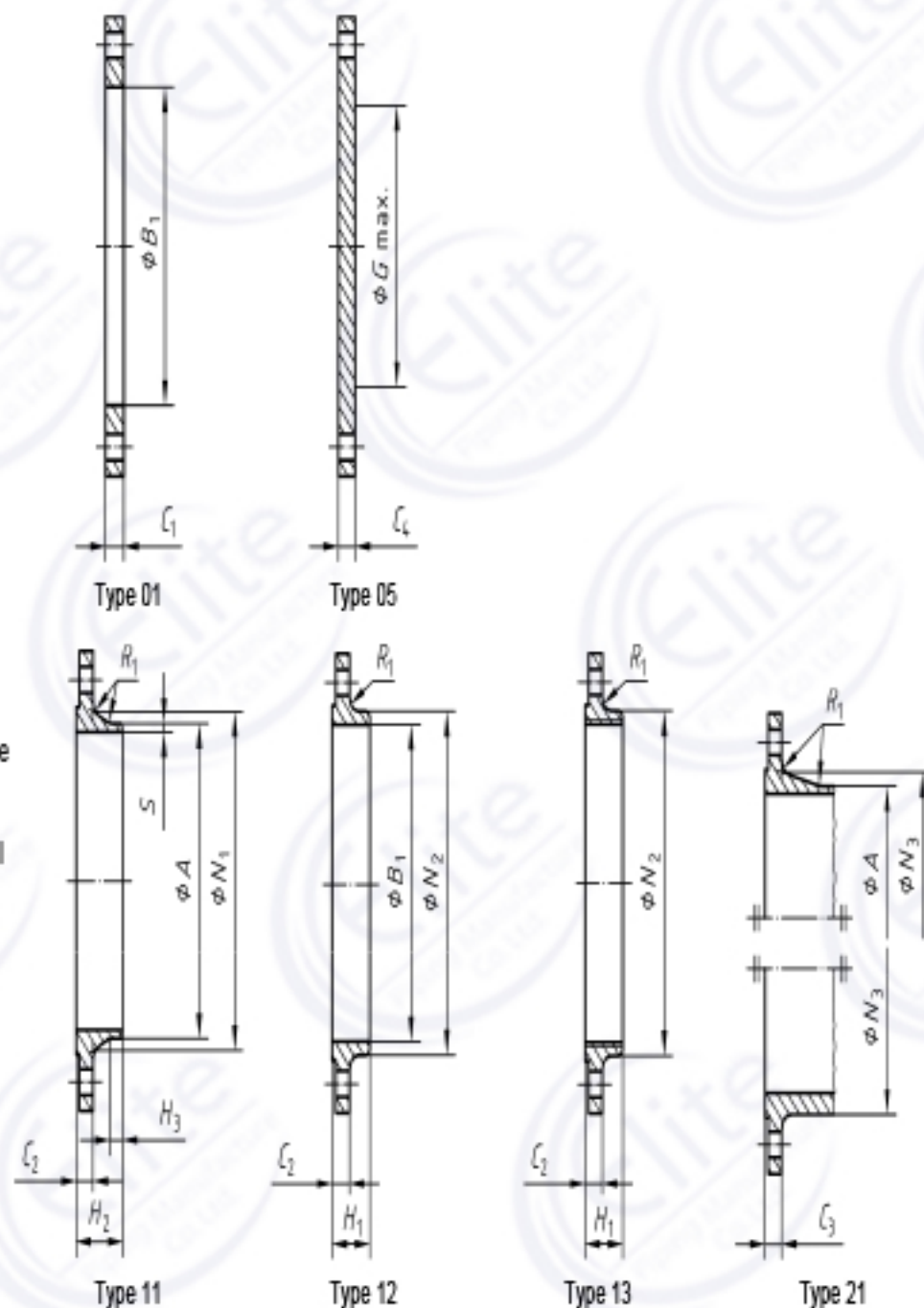

NOTE 1 Dimensions  $N_1$ ,  $N_2$  and  $N_3$  are measured at the intersection of the hub draft angle and the back face of the flange.

NOTE 2 For dimensions  $C_{max}$  refer to NOTE 1 of 5.6.1.

Figure 11 — Dimensions of PN 63 flanges

Table 16 — Dimensions of PN 63 flanges

Dimensions in millimetres

DN	Mating dimensions				Outside diameter of neck	Bore diameter	Flange thickness				Diameter of shoulder	Length			Neck diameters			Corner radii	Wall thickness (see 5.6.1)
	Outside diameter	Diameter of bolt circle	Diameter of bolt hole	Bolt			C <sub>1</sub>	C <sub>2</sub>	C <sub>3</sub>	C <sub>4</sub>		H <sub>1</sub>	H <sub>2</sub>	H <sub>3</sub>	N <sub>1</sub>	N <sub>2</sub>	N <sub>3</sub>		
				Number	Size	A					B <sub>1</sub>							G max	D <sub>1</sub>
	Flange type																		
	01, 05, 11, 12, 13, 21				11 21 <sup>a</sup>	01 12	01	11 12 13	21	05	05	12 13	11	11	11	12 13	21	11 12 13 21	11
10	100	70	14	4	M12	17,2	18,0	20	20	20	20	—	28	45	6	32	40	40	4
15	105	75	14	4	M12	21,3	22,0	20	20	20	20	—	28	45	6	34	43	45	4
20	130	90	18	4	M16	26,9	27,5	22	22	22	22	—	30	48	8	42	52	50	4
25	140	100	18	4	M16	33,7	34,5	24	24	24	24	—	32	58	8	52	60	61	4
32	155	110	22	4	M20	42,4	43,5	24	24	26	24	—	32	60	8	62	68	68	6
40	170	125	22	4	M20	48,3	49,5	26	26	28	26	—	34	62	10	70	80	82	6
50	180	135	22	4	M20	60,3	61,5	26	26	26	26	—	36	62	10	82	90	90	6
65	205	160	22	8	M20	76,1	77,5	26	26	26	26	45	40	68	12	98	112	105	6
80	215	170	22	8	M20	88,9	90,5	30	28	28	28	60	44	72	12	112	125	122	8
100	250	200	26	8	M24	114,3	116,0	32	30	30	30	80	52	78	12	138	152	146	8
125	295	240	30	8	M27	139,7	141,5	34	34	34	34	105	56	88	12	168	185	177	8
150	345	280	33	8	M30	168,3	170,5	36	36	36	36	130	60	95	12	202	215	204	10
200	415	345	36	12	M33	219,1	221,5	48	42	42	42	180	—	110	16	256	—	264	10
250	470	400	36	12	M33	273,0	276,5	55	46	46	46	220	—	125	18	316	—	320	12
300	530	460	36	16	M33	323,9	327,5	65	52	52	52	270	—	140	18	372	—	378	12
350	600	525	39	16	M36	355,6	359,5	72	56	56	56	310	—	150	20	420	—	434	12
400	670	585	42	16	M39	406,4	411,0	80	60	60	60	360	—	160	20	475	—	490	12
500	b																		
600																			
700																			
800																			
900																			
1 000																			
1 200																			

See Annex A

<sup>a</sup> For flanges type 21 the outside hub diameter approximately corresponds to the outside pipe diameter.

<sup>b</sup> Only mating dimensions fixed, see Annex J.

EN 1092-1:2007 (E)

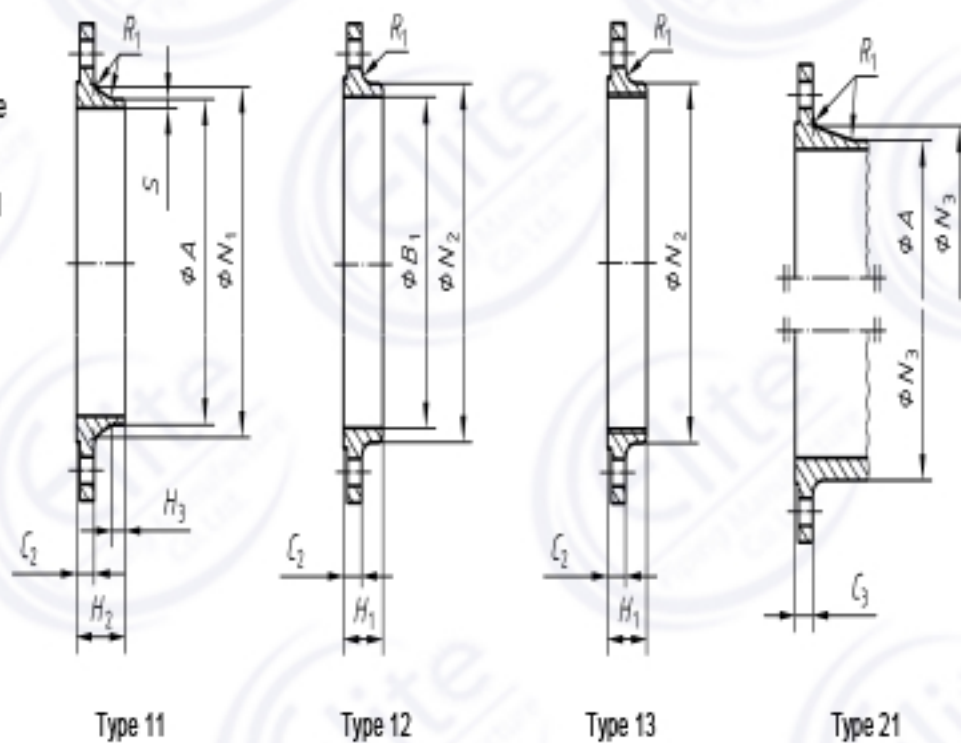
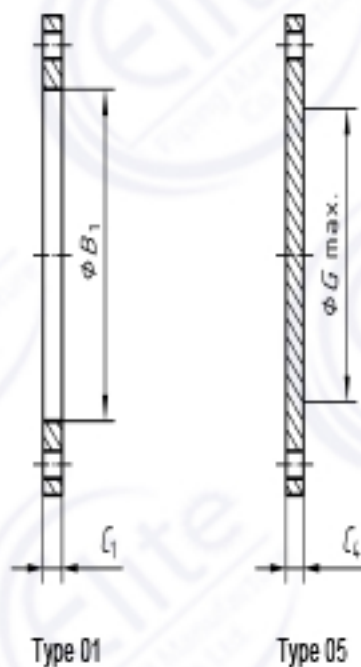
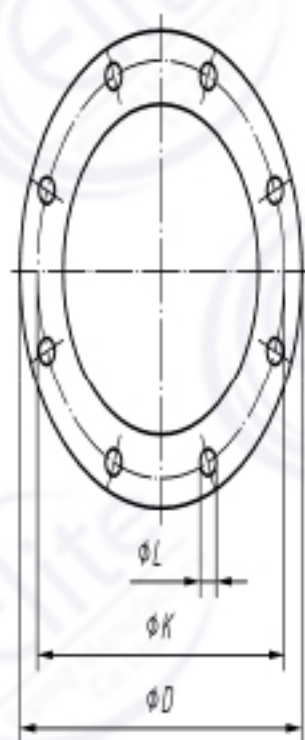

This diagram illustrates the arrangement but not necessarily the correct number of bolt holes.

Refer to the column "Bolting Number" in Table 17 for the actual number.

NOTE 1 Dimensions  $N_1$ ,  $N_2$  and  $N_3$  are measured at the intersection of the hub draft angle and the back face of the flange.

NOTE 2 For dimensions  $C_{max}$  refer to NOTE 1 of 5.6.1.

Figure 12 — Dimensions of PN 100 flanges

Table 17 — Dimensions of PN 100 flanges

Dimensions in millimetres

DN	Mating dimensions						Outside diameter of neck A	Bore diameter B <sub>1</sub>	Flange thickness				Diameter of shoulder G <sub>max</sub>	Length			Neck diameters			Corner radii R <sub>1</sub>	Wall thickness (see 5.6.1) S
	Outside diameter D	Diameter of bolt circle K	Diameter of bolt hole L	Bolting		C <sub>1</sub>			C <sub>2</sub>	C <sub>3</sub>	C <sub>4</sub>	H <sub>1</sub>		H <sub>2</sub>	H <sub>3</sub>	N <sub>1</sub>	N <sub>2</sub>	N <sub>3</sub>			
				Number	Size																
Flange type																					
01, 05, 11, 12, 13, 21						11 21 <sup>a</sup>	01 12	01	11 12 13	21	05	05	12 13	11	11	11	12 13	21	11 12 13 21	11	
10	100	70	14	4	M12	17,2	18,0	20	20	20	20	—	28	45	6	32	40	40	4	See Annex A	
15	105	75	14	4	M12	21,3	22,0	20	20	20	20	—	28	45	6	34	43	45	4		
20	130	90	18	4	M16	26,9	27,5	22	22	22	22	—	30	48	8	42	52	50	4		
25	140	100	18	4	M16	33,7	34,5	24	24	24	24	—	32	58	8	52	60	61	4		
32	155	110	22	4	M20	42,4	43,5	24	24	26	24	—	32	60	8	62	68	68	6		
40	170	125	22	4	M20	48,3	49,5	26	26	28	26	—	34	62	10	70	80	82	6		
50	195	145	26	4	M24	60,3	61,5	28	28	30	28	—	36	68	10	90	95	96	6		
65	220	170	26	8	M24	76,1	77,5	30	30	34	30	45	40	76	12	108	118	118	6		
80	230	180	26	8	M24	88,9	90,5	34	32	36	32	60	44	78	12	120	130	128	8		
100	265	210	30	8	M27	114,3	116,0	36	36	40	36	80	52	90	12	150	158	150	8		
125	315	250	33	8	M30	139,7	141,5	42	40	40	40	105	56	105	12	180	188	185	8		
150	355	290	33	12	M30	168,3	170,5	48	44	44	44	130	60	115	12	210	225	216	10		
200	430	360	36	12	M33	219,1	221,5	60	52	52	52	180	—	130	16	278	—	278	10		
250	505	430	39	12	M36	273,0	276,5	72	60	60	60	210	—	157	18	340	—	340	12		
300	585	500	42	16	M39	323,9	327,5	84	68	68	68	260	—	170	18	400	—	407	12		
350	655	560	48	16	M45	355,6	359,5	95	74	74	74	300	—	189	20	460	—	460	12		
400	b																				
500																					

<sup>a</sup> For flanges type 21 the outside hub diameter approximately corresponds to the outside pipe diameter.  
<sup>b</sup> Only mating dimensions fixed, see Annex J.

EN 1092-1:2007 (E)

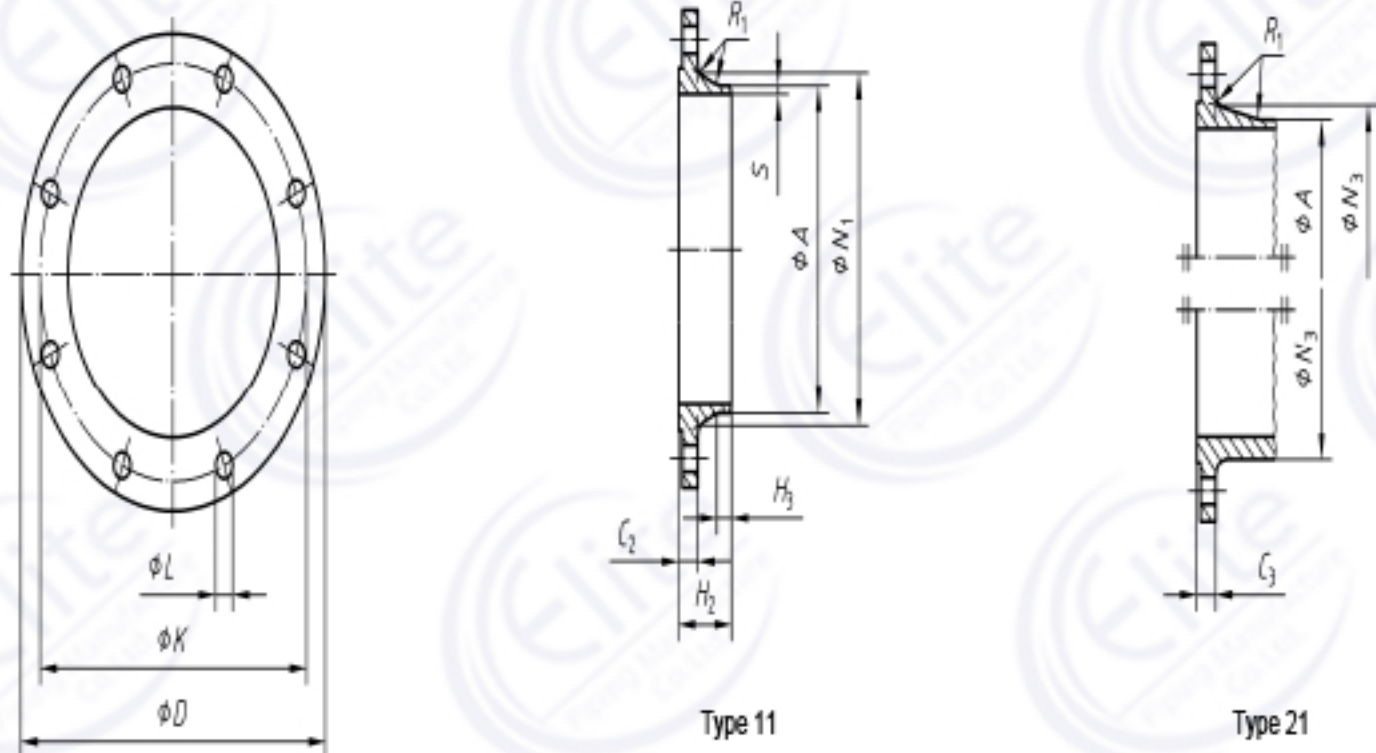

This diagram illustrates the arrangement but not necessarily the correct number of bolt holes.

Refer to the column "Bolting Number" in Table 18 for the actual number.

NOTE Dimensions  $N_1$  and  $N_3$  are measured at the intersection of the hub draft angle and the back face of the flange.

Figure 13 — Dimensions of PN 160 flanges



Table 18 — Dimensions of PN 160 flanges

Dimensions in millimetres

DN	Mating dimensions					Outside diameter of neck A	Flange thickness		Length		Neck diameters		Corner radii		Wall thickness (see 5.6.1) S
	Outside diameter D	Diameter of bolt circle K	Diameter of bolt hole L	Bolting			C <sub>2</sub>	C <sub>3</sub>	R <sub>2</sub>	R <sub>3</sub>	N <sub>1</sub>	N <sub>2</sub>	R <sub>1</sub>		
				Number	Size										
	Flange type														
	11, 21					11 21 <sup>a</sup>	11	21	11	11	11	21	11	21	11
10	100	70	14	4	M12	17,2	20	20	45	6	32	40	4	4	2,0
15	105	75	14	4	M12	21,3	20	20	45	6	34	45	4	4	2,0
25	140	100	18	4	M16	33,7	24	24	58	8	52	61	4	4	2,9
40	170	125	22	4	M20	48,3	28	28	64	10	70	82	6	4	3,6
50	195	145	26	4	M24	60,3	30	30	75	10	90	96	6	4	4,0
65	220	170	26	8	M24	76,1	34	34	82	12	108	118	6	5	5,0
80	230	180	26	8	M24	88,9	36	36	86	12	120	128	8	5	6,3
100	265	210	30	8	M27	114,3	40	40	100	12	150	150	8	5	8,0
125	315	250	33	8	M30	139,7	44	44	115	14	180	184	8	6	10,0
150	355	290	33	12	M30	168,3	50	50	128	14	210	224	10	6	12,5
200	430	360	36	12	M33	219,1	60	60	140	16	278	288	10	8	16,0
250	515	430	42	12	M39	273,0	68	68	155	18	340	346	12	8	20,0
300	585	500	42	16	M39	323,9	78	78	175	18	400	414	12	10	22,2

<sup>a</sup> For flanges type 21 the outside hub diameter approximately corresponds to the outside pipe diameter.

EN 1092-1:2007 (E)

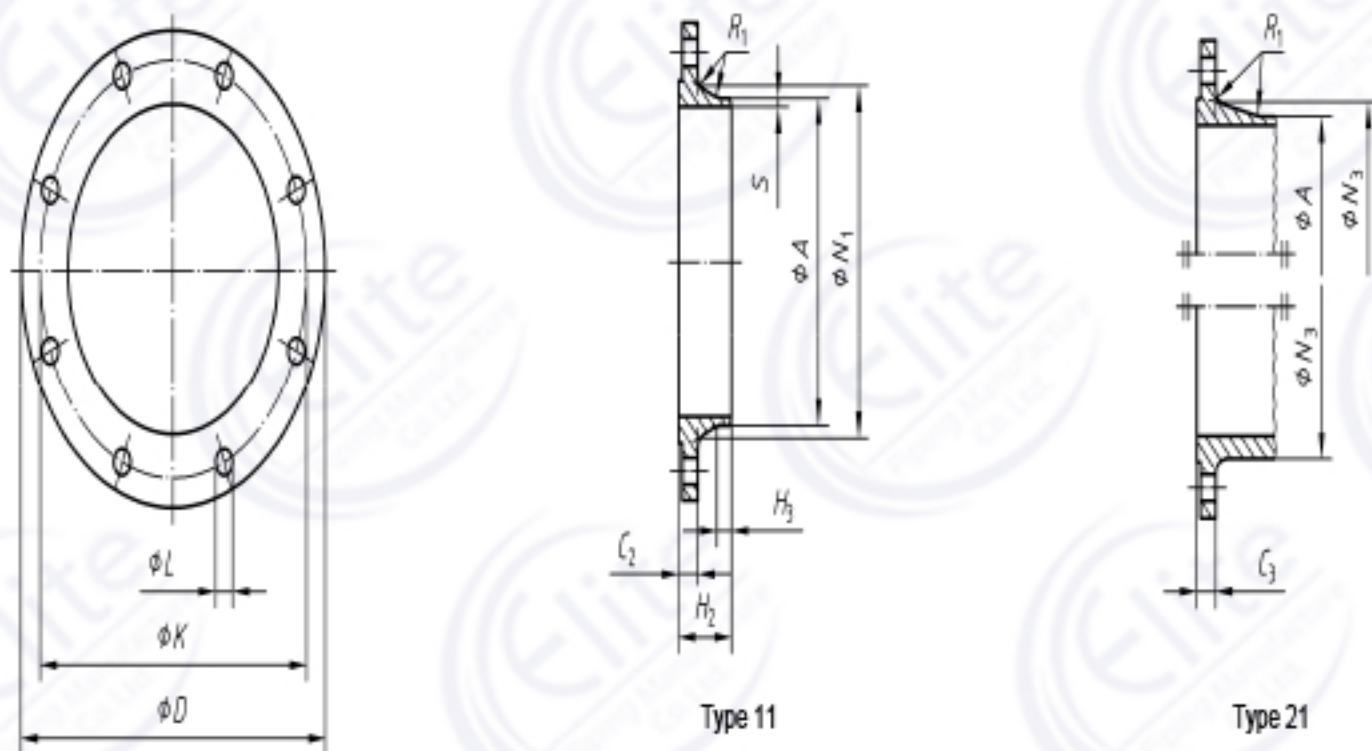

This diagram illustrates the arrangement but not necessarily the correct number of bolt holes.

Refer to the column "Bolting Number" in Table 19 for the actual number.

NOTE Dimensions  $N_1$  and  $N_3$  are measured at the intersection of the hub draft angle and the back face of the flange.

Figure 14 — Dimensions of PN 250 flanges

Table 19 — Dimensions of PN 250 flanges

Dimensions in millimetres

DN	Mating dimensions					Outside diameter of neck A	Flange thickness		Length		Neck diameters		Corner radii		Wall thickness (see 5.6.1) S
	Outside diameter D	Diameter of bolt circle K	Diameter of bolt hole L	Bolting			C <sub>2</sub>	C <sub>3</sub>	H <sub>2</sub>	H <sub>3</sub>	N <sub>1</sub>	N <sub>3</sub>	R <sub>1</sub>	R <sub>2</sub>	
	Number		Size												
	Flange type														
	11, 21					11 21 <sup>a</sup>	11	21	11	11	11	21	11	21	11
10 <sup>b,c</sup>	125	85	18	4	M16	—	—	24	—	—	—	46	—	4	—
15	130	90	18	4	M16	21,3	26	26	60	6	48	52	4	4	2,6
25	150	105	22	4	M20	33,7	28	28	65	8	60	63	4	4	3,6
40	185	135	26	4	M24	48,3	34	34	80	10	84	90	6	4	5,0
50	200	150	26	8	M24	60,3	38	38	85	10	95	102	6	5	6,3
65	230	180	26	8	M24	76,1	42	42	95	12	124	125	6	5	8,0
80	255	200	30	8	M27	101,6	46	46	102	12	136	142	8	6	11,0
100	300	235	33	8	M30	127,0	54	54	120	14	164	168	8	6	14,2
125	340	275	33	12	M30	152,4	60	60	140	16	200	207	8	6	16,0
150	390	320	36	12	M33	177,8	68	68	160	18	240	246	10	8	17,5
200	485	400	42	12	M39	244,5	82	82	190	25	305	314	10	8	25,0
250	585	490	48	16	M45	298,5	100	100	215	30	385	394	12	10	32,0
300 <sup>b</sup>	690	590	52	16	M48	—	—	120	—	—	—	480	—	10	—

<sup>a</sup> For flanges type 21 the outside hub diameter approximately corresponds to the outside pipe diameter.  
<sup>b</sup> For flanges type 21.  
<sup>c</sup> For flanges type 11 use flanges PN 320.

EN 1092-1:2007 (E)

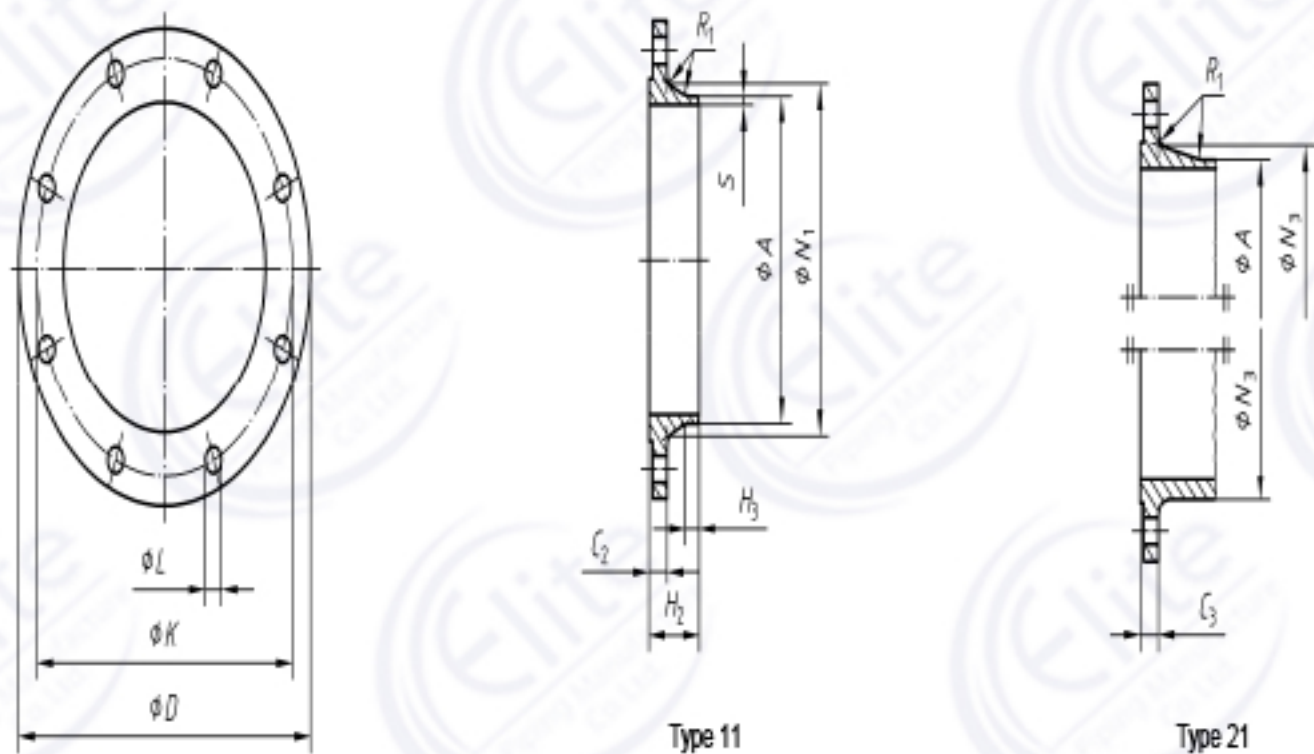

This diagram illustrates the arrangement but not necessarily the correct number of bolt holes.

Refer to the column "Bolting Number" in Table 20 for the actual number.

NOTE Dimensions  $N_1$  and  $N_3$  are measured at the intersection of the hub draft angle and the back face of the flange.

Figure 15 — Dimensions of PN 320 flanges

Table 20 — Dimensions of PN 320 flanges

Dimensions in millimetres

DN	Mating dimensions					Outside diameter of neck A	Flange thickness		Length		Neck diameters		Corner radii		Wall thickness (see 5.6.1) S
	Outside diameter D	Diameter of bolt circle K	Diameter of bolt hole L	Bolting			C <sub>2</sub>	C <sub>3</sub>	R <sub>2</sub>	R <sub>3</sub>	N <sub>1</sub>	N <sub>2</sub>	R <sub>1</sub>		
				Number	Size										
	Flange type														
11, 21						11 21 <sup>a</sup>	11	21	11	11	11	21	11	21	
10	125	85	18	4	M16	17,2	24	24	58	6	44	46	4	4	2,6
15	130	90	18	4	M16	21,3	26	26	60	6	48	52	4	4	3,2
25	160	115	22	4	M20	33,7	34	34	78	8	68	72	4	4	5,0
40	195	145	26	4	M24	48,3	38	38	88	10	92	96	6	5	6,3
50	210	160	26	8	M24	63,5	42	42	100	10	106	110	6	5	8,0
65	255	200	30	8	M27	88,9	51	51	120	12	138	137	6	6	11,0
80	275	220	30	8	M27	101,6	55	55	130	14	156	160	8	6	12,5
100	335	265	36	8	M33	133,0	65	65	145	16	186	190	8	8	16,0
125	380	310	36	12	M33	168,3	75	75	175	20	230	235	8	8	20,0
150	425	350	39	12	M36	193,7	84	84	195	25	265	266	10	10	25,0
200	525	440	42	16	M39	244,5	103	103	235	30	345	350	10	10	30,0
250	640	540	52	16	M48	323,9	125	125	300	40	428	432	12	10	40,0

<sup>a</sup> For flanges type 21 the outside hub diameter approximately corresponds to the outside pipe diameter.

EN 1092-1:2007 (E)

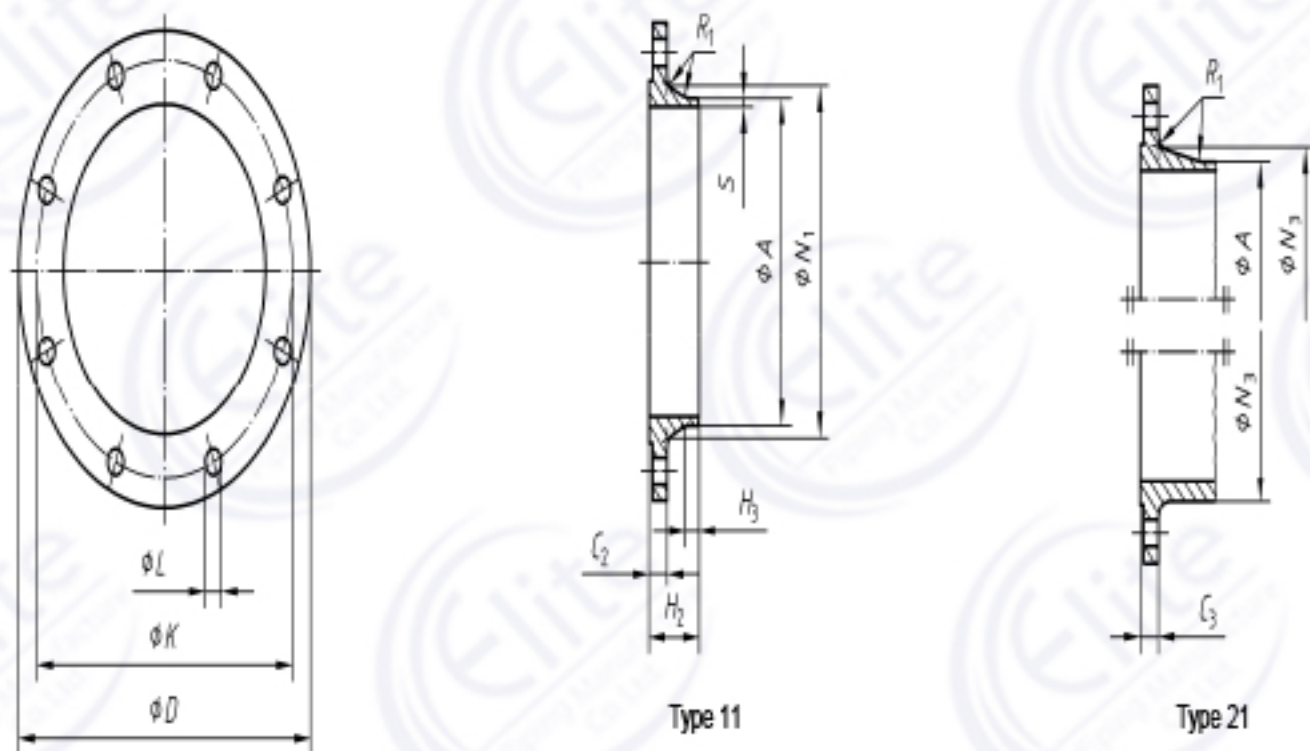

This diagram illustrates the arrangement but not necessarily the correct number of bolt holes.

Refer to the column "Bolting Number" in Table 21 for the actual number.

NOTE Dimensions  $N_1$  and  $N_3$  are measured at the intersection of the hub draft angle and the back face of the flange.

Figure 16 — Dimensions of PN 400 flanges

Table 21 — Dimensions of PN 400 flanges

Dimensions in millimetres

DN	Mating dimensions						Outside diameter of neck A	Flange thickness		Length		Neck diameters		Corner radii		Wall thickness (see 5.6.1) S
	Outside diameter D	Diameter of bolt circle K	Diameter of bolt hole L	Bolting		C <sub>2</sub>		C <sub>3</sub>	R <sub>6</sub>	R <sub>9</sub>	N <sub>1</sub>	N <sub>3</sub>	R <sub>1</sub>	R <sub>2</sub>		
				Number	Size											
	Flange type															
	11, 21						11 21 <sup>a</sup>	11	21	11	11	11	21	11	21	11
10	125	85	18	4	M16	17,2	28	28	65	8	48	48	4	4	3,6	
15	145	100	22	4	M20	26,9	30	30	68	8	56	57	4	4	5,0	
25	180	130	26	4	M24	42,4	38	38	90	10	82	81	4	5	7,1	
40	220	165	30	4	M27	60,3	48	48	110	12	106	105	6	5	10,0	
50	235	180	30	8	M27	76,1	52	52	120	15	120	120	6	6	12,5	
65	290	225	33	8	M30	101,6	64	64	135	18	158	158	6	6	16,0	
80	305	240	33	8	M30	114,3	68	68	150	20	174	174	8	8	17,5	
100	370	295	39	8	M36	139,7	80	80	175	25	216	216	8	8	22,2	
125	415	340	39	12	M36	193,7	92	92	200	30	258	259	8	10	30,0	
150	475	390	42	12	M39	219,1	105	105	225	35	302	302	10	10	35,0	
200	585	490	48	16	M45	273,0	130	130	280	40	388	388	10	10	40,0	

<sup>a</sup> For flanges type 21 the outside hub diameter approximately corresponds to the outside pipe diameter.

Table 22 — Tolerances

Dimension	Flange Type	Size	Tolerance mm		
Outside diameter of neck <i>A</i>	11, 21, 34	≤ DN 125	+ 3,0 0		
		> DN 125 ≤ DN 1200	+ 4,5 0		
		> DN 1200	+ 6,0 0		
	35, 36, 37	≤ DN 150	± 0,75 % <sup>a</sup> , min. ± 0,3 mm		
		> DN 150	± 1 % <sup>a</sup> , max ± 3,0 mm		
Bore diameter <i>B</i> <sub>1</sub> , <i>B</i> <sub>2</sub> , <i>B</i> <sub>3</sub>	01, 02, 04, 12, 32	≤ DN 100	+ 0,5 0		
		> DN 100 ≤ DN 400	+ 1,0 0		
		> DN 400 ≤ DN 600	+ 1,5 0		
		> DN 600	+ 3,0 0		
Wall thickness <i>S</i> <sup>c</sup>	11, 34 <sup>b</sup>		machined neck (both faces)	neck one face ma- chined or un- machined	
		≤ DN 100	+ 1,0 0	+ 2,0 0	
		> DN 100 ≤ DN 400	+ 1,5 0	+ 2,5 0	
	35	> DN 400		+ 2,0 0	+ 3,5 0
			S ≤ 8	+ 15 % - 10 %	
	36, 37	S > 8		+ 15 % - 5 %	
			≤ DN 600	- 12,5 % <sup>a</sup> + 15 %	
			> DN 600	- 0,5 mm <sup>a</sup> + 15 %	
Bevelled wall thickness <i>S</i> <sub>p</sub>	35, 36, 37	S ≤ 8	+ 1,0 0		
		S > 8	+ 2,0 0		
Outside diameter <i>D</i>	21	≤ DN 250	± 4,0		
		> DN 250 ≤ DN 500	± 5,0		
		> DN 500 ≤ DN 800	± 6,0		
		> DN 800 ≤ DN 1200	± 7,0		
		> DN 1200 ≤ DN 1600	± 8,0		
		> DN 1600 ≤ DN 2000	± 10,0		
	All other types	≤ DN 150	± 2,0		
		> DN 150 ≤ DN 500	± 3,0		
		> DN 500 ≤ DN 1200	± 5,0		
		> DN 1200 ≤ DN 1800	± 7,0		
		> DN 1800	± 10,0		



Table 22 (continued)

Dimension	Flange Type	Size	Tolerance mm
Length through hub $H_1, H_2, H_3, H_4, H_5$	11, 12, 13, 34, 35, 36, 37	$\leq$ DN 80	$\pm 1,5$
		$>$ DN 80 $\leq$ DN 250	$\pm 2,0$
		$>$ DN 250	$\pm 3,0$
Neck diameter $N_1, N_2, N_3$	11, 21, 34	$\leq$ DN 50	0 - 2,0
		$>$ DN 50 $\leq$ DN 150	0 - 4,0
		$>$ DN 150 $\leq$ DN 300	0 - 6,0
		$>$ DN 300 $\leq$ DN 600	0 - 8,0
		$>$ DN 600 $\leq$ DN 4000	0 - 10,0
	12, 13	$\leq$ DN 50	+ 1,0 0
		$>$ DN 50 $\leq$ DN 150	+ 2,0 0
		$>$ DN 150 $\leq$ DN 300	+ 4,0 0
		$>$ DN 300 $\leq$ DN 600	+ 8,0 0
		$>$ DN 600 $\leq$ DN 1200	+ 12,0 0
		$>$ DN 1200 $\leq$ DN 1800	+ 16,0 0
		$>$ DN 1800	+ 20,0 0
Collar thickness F	35 (machined on both faces)	$\leq$ 18 mm thickness	$\pm 1,0$ mm
		$>$ 18 mm $\leq$ 50 mm thickness	$\pm 1,5$ mm
	38 (machined on front face only or un-machined)	$\leq$ 18 mm thickness	$\pm 10$ %
37 (un-machined)	$\leq$ 5 mm thickness	$\pm 0,20$ mm	
Flange thickness $C_1, C_2, C_3, C_4$	All types (machined on both faces)	$\leq$ 18 mm thickness	+ 1,0 - 1,3
		$>$ 18 mm $\leq$ 50 mm thickness	$\pm 1,5$
		$>$ 50 mm thickness	$\pm 2,0$
	All types (machined on front face only) Type 02 and 04 (un-machined)	$\leq$ 18 mm thickness	+ 2,0 - 1,3
		$>$ 18 mm $\leq$ 50 mm thickness	+ 4,0 - 1,5
		$>$ 50 mm thickness	+ 7,0 - 2,0
Collar thickness F	32, 34		
Facing diameter $d_1$	All types	$\leq$ DN 250	+ 2,0 - 1,0
		$>$ DN 250	+ 3,0 - 1,0

Table 22 (concluded)

Dimension		Flange type	Size		Tolerance mm
Facing height $f_1$		All types (facing type B, D, F and G)	≤ DN 32	2 mm	0 -1
			> DN 32 to DN 250	3 mm	0 -2
			> DN 250 to DN 500	4 mm	0 -3
			> DN 500	5 mm	0 -4
Facing height $f_2$		All types (facing types C, E and G)	All DN		+0,5 0
Facing height $f_3$		All types (facing types D and F)	All DN		+0,5 0
		All types (facing type H)	All DN		+0,2 0
Facing height $f_4$		All types (facing type H)	All DN		+0,5 0
Facing	$W$	All types	All DN		+0,5 0
	$X$				0 -0,5
	$Y$				+0,5 0
	$Z$				0 -0,5
Diameter of bolt circle $K$	All types		Bolt sizes M10 to M24		± 1,0
			Bolt sizes M27 to M45		± 1,5
Centre-to-centre of adjacent bolt holes	All types		Bolt sizes M10 to M24		± 1,0
			Bolt sizes M27 to M45		± 1,5
Eccentricity of machined facing diameters	All types		≤ DN 65		1,0
			> DN 65		2,0
Parallelism between bolting bearing surfaces and flange jointing faces	All types (machined bearing surfaces)	All DN			1°
	All types (un-machined bearing surfaces)				2°
<p><sup>a</sup> Tolerance in % from the outside diameter or respectively from the wall thickness.</p> <p><sup>b</sup> Bore tolerance not applicable.</p> <p><sup>c</sup> Preparation of ends see Annex A.</p>					

Table 23 — Corner radii  $R_1$  and hub radius  $R_2$  after back facing

Flange size	$R_1$ min. <sup>a</sup> mm	$R_1$ max. <sup>a</sup> mm	$R_2$ min. mm
Up to and including DN 50	3	5	1,6
Over DN 50 and up to including DN 350	3	6	2,4
Over DN 350	5	8	3,2

<sup>a</sup> Dimensions  $R_1$  are valid for types 33 to 37.  
Dimensions  $R_1$  for other types 11, 12, 13 and 21, see Tables 10 to 21.



Figure 17 — Minimum hub radius after back facing

## Annex A (normative)

### Wall thickness and end preparation

#### A.1 Weld-end preparation for flanges types 11 and 34

Unless otherwise specified, for flanges in accordance with this European Standard the welding end connections given in Figures A.1 to A.3 shall be used. Additional types of welding ends are specified in EN ISO 9692-2 and example of designs in EN 1708-1 and may be used by agreement between the component or pressure equipment manufacturer and the flange manufacturer.

- Wall thickness  $S \leq 3$  mm: Flanges/collars may be delivered with square cut ends.
- Wall thickness  $3 < S < 22$ : Bevelled ends with an angle of  $30^\circ \begin{smallmatrix} +5^\circ \\ -0^\circ \end{smallmatrix}$  and root face of  $(1,6 \pm 0,8)$  mm.
- If flange wall thickness ( $S$ ) > pipe wall thickness ( $T$ ), the inner diameter shall be chamfered with an angle of  $15^\circ \begin{smallmatrix} +5^\circ \\ -0^\circ \end{smallmatrix}$  to match (see Figure A.3).

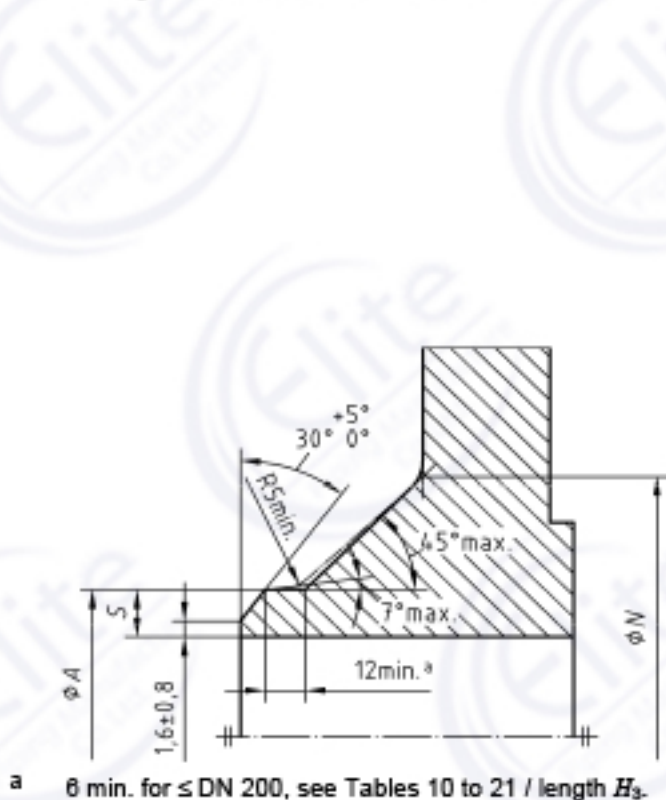

Figure A.1 — Welding end connection for wall thickness  $S$  up to 22 mm

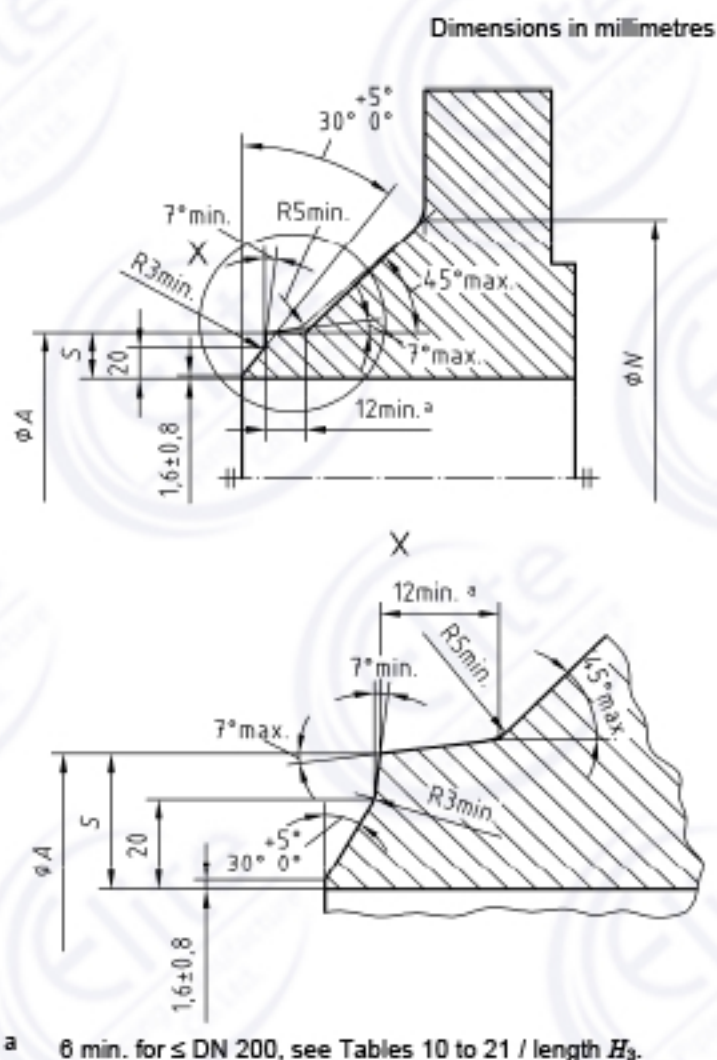
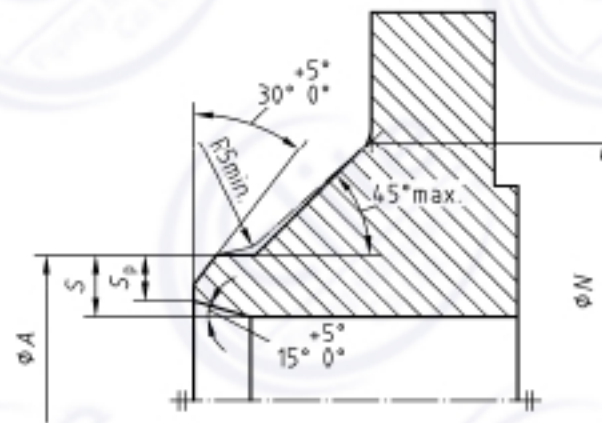

Figure A.2 — Welding end connection for wall thickness  $S \geq 22$  mm



$S$  Flange wall thickness

$S_p$  Reduced flange wall thickness

**Figure A.3 — Permissible bevel design for unequal wall thickness**

**NOTE 1** For flanges required to connect to non-austenitic steel pipe of nominal wall thickness less than 4,8 mm, the welding ends should be finished to a slight chamfer or be square, at the option of the flange manufacturer, if nothing else has been agreed between flange manufacturer and purchaser or pressure equipment manufacturer.

**NOTE 2** For flanges required to connect to austenitic stainless steel pipe of nominal wall thickness 3,2 mm or less, the welding ends should be square cut ends.

**NOTE 3** The mating wall thickness of the flange ( $S_p$ ) shall match to the pipe wall thickness ( $T$ ).

Table A.1 — Wall thickness for type 11

Ø A	PN 2,5		PN 6		PN 10		PN 16		PN 25		PN 40		PN 63		PN 100	
	<i>s</i>	<i>Sp</i>	<i>s</i>	<i>Sp</i>	<i>s</i>	<i>Sp</i>	<i>s</i>	<i>Sp</i>	<i>s</i>	<i>Sp</i>	<i>s</i>	<i>Sp</i>	<i>s</i>	<i>Sp</i>	<i>s</i>	<i>Sp</i>
17,2	2	2	2	2	2	2	2	2	2	2	2	2	2	2	2	2
21,3	2	2	2	2	2	2	2	2	2	2	2	2	2	2	3,2	2
26,9	2,3	2,3	2,3	2,3	2,3	2,3	2,3	2,3	2,3	2,3	2,3	2,3	2,3	2,6	2,3	2,3
33,7	2,6	2,6	2,6	2,6	2,6	2,6	2,6	2,6	2,6	2,6	2,6	2,6	2,6	2,6	2,6	2,6
42,4	2,6	2,6	2,6	2,6	2,6	2,6	2,6	2,6	2,6	2,6	2,6	2,6	2,6	2,9	2,6	2,6
48,3	2,6	2,6	2,6	2,6	2,6	2,6	2,6	2,6	2,6	2,6	2,6	2,6	2,6	2,9	2,9	3,6
60,3	2,9	2,9	2,9	2,9	2,9	2,9	2,9	2,9	2,9	2,9	2,9	2,9	2,9	4	3,2	4
76,1	2,9	2,9	2,9	2,9	2,9	2,9	2,9	2,9	2,9	2,9	2,9	2,9	2,9	4	3,6	4
88,9	3,2	3,2	3,2	3,2	3,2	3,2	3,2	3,2	3,2	3,2	3,2	3,2	3,2	4,5	4	5
114,3	3,6	3,6	3,6	3,6	3,6	3,6	3,6	3,6	3,6	3,6	3,6	3,6	3,6	4,5	4,5	5,6
139,7	4	4	4	4	4	4	4	4	4	4	4	4	4	5,6	5,6	6,3
168,3	4,5	4,5	4,5	4,5	4,5	4,5	4,5	4,5	4,5	4,5	4,5	4,5	4,5	6,3	6,3	8
219,1	6,3	6,3	6,3	6,3	6,3	6,3	6,3	6,3	6,3	6,3	6,3	6,3	6,3	7,1	7,1	8,8
273	6,3	6,3	6,3	6,3	6,3	6,3	6,3	6,3	6,3	7,1	7,1	7,1	7,1	8,8	8,8	10
323,9	7,1	7,1	7,1	7,1	7,1	7,1	7,1	7,1	7,1	8	8	8	8	11	10	12,5
355,6	7,1	7,1	7,1	7,1	7,1	7,1	7,1	8	8	8	8	8,8	8,8	12,5	10	14,2
406,4	7,1	7,1	7,1	7,1	7,1	7,1	7,1	8	8	8,8	8,8	11	11	14,2	11	16
457	7,1	7,1	7,1	7,1	7,1	7,1	7,1	8	8	8,8	8,8	12,5	12,5			
508	7,1	7,1	7,1	7,1	7,1	7,1	7,1	8	8	10	10	14,2	14,2			
610	7,1	7,1	7,1	7,1	8	7,1	10	8,8	11	11	16	16				
711	7,1	7,1	8	7,1	8,8	8	10	8,8	14,2	12,5						
813	7,1	7,1	8	7,1	8,8	8	12,5	10	16	14,2						
914	7,1	7,1	8	7,1	12,5	10	12,5	10	17,5	16						
1 016	7,1	7,1	8	7,1	12,5	10	12,5	10	20	17,5						
1 219	8	7,1	8,8	8	12,5	11	14,2	12,5								
1 422	8	7,1	8,8	8	14,2	12,5	16	14,2								
1 626	8,8	8	10	9	16	14,2	17,5	16								
1 829	10	10	11	10	17,5	16	20	17,5								
2 032	11	10	12,5	11	17,5	16	22	20								
2 235	11	10	14	12,5	20	18										
2 438	11	10	15	14,2	22,2	20										
2 620	11	10	16	14,2	25	22,2										
2 820	11	10	17	16	25	22,2										
3 020	11	10	20	16	32	24										
3 220	11	10	20	16												
3 420	11	10	22	17,5												
3 620	11	10	22	17,5												
3 820	11	10														
4 020	11	10														

NOTE *Sp* valves shall match those given in EN 10220 respectively EN ISO 1127.

## A.2 Weld-end preparation for type 35

Dimensions see Table A.2

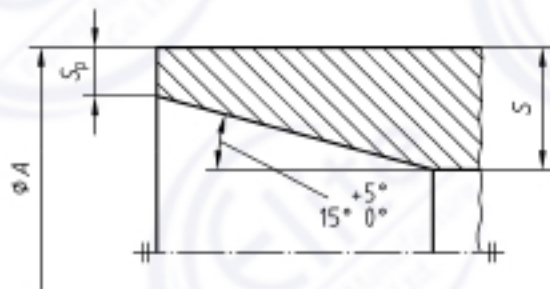

Figure A.4 — Chamfer A for type 35

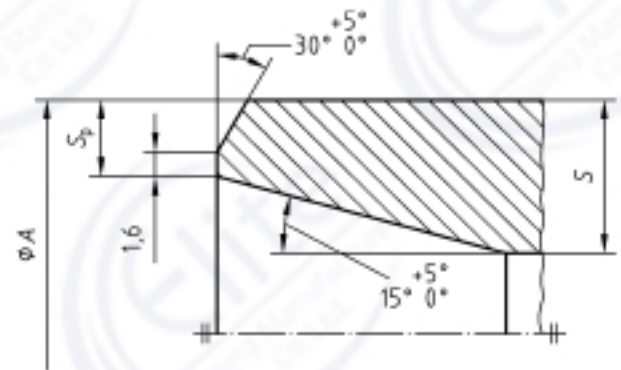

Figure A.5 — Chamfer B for type 35

Table A.2 — Wall thickness for type 35

$\varnothing A$	PN 2,5		PN 6		PN 10		PN 16		PN 25		PN 40		Chamfer
	$s$	$S_p$	$s$	$S_p$	$s$	$S_p$	$s$	$S_p$	$s$	$S_p$	$s$	$S_p$	
17,2	3	2	3	2	3	2	3	2	3	2	3	2	A
21,3	3	2	3	2	3	2	3	2	3	2	3	2	
26,9	3	2	3	2	3	2	3	2	3	2	3	2	
33,7	3	2	3	2	3	2	3	2	3	2	3	2	
42,4	3	2	3	2	3	2	3	2	3	2	3	2	
48,3	3	2	3	2	3	2	3	2	3	2	3	2	
60,3	3	2	3	2	3	2	3	2	4	2,6	4	2,6	
76,1	4	2	4	2	4	2	4	2	5	2,6	5	2,6	
88,9	4	2	4	2	4	2	4	2	6	2,6	6	2,6	
114,3	4	2	4	2	4	2	4	2	6	3,2	6	3,2	
139,7	5	2	5	2	5	2	5	2	6	3,2	6	3,2	
168,3	6	2	6	2	6	2	6	2	8	3,2	8	4	B
219,1	6	2,6	6	2,6	6	2,6	6	2,6	8	3,2	10	5	
273	8	3,2	8	3,2	8	3,2	8	3,2	10	5	12	6,3	
323,9	8	3,2	8	3,2	8	3,2	10	4	10	6,3	12	8	
355,6	8	3,2	8	3,2	8	3,2	10	4	12	6,3	14	8	
406,4	8	3,2	8	3,2	8	3,2	12	5	14	8	16	10	
457	8	3,6	8	3,6	8	3,6	12	5	15	8			
508	8	4	8	4	8	4	12	6,3	16	10			
610	8	5	8	5	10	5	12	8	18	10			
711	8	5	8	5	10	6,3	14	8	20	14,2			
813	10	6,3	10	6,3	12	6,3	16	10	20	14,2			
914	10	6,3	10	6,3	12	8	18	10					
1 016	12	8	12	8	12	8	18	10					
1 219	14	10	14	10	16	10							

### A.3 Weld end preparation for types 36 and 37

Dimensions see Table A.3.

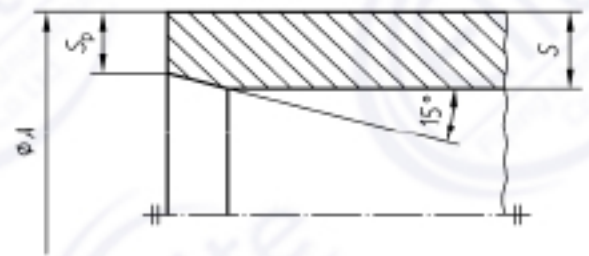
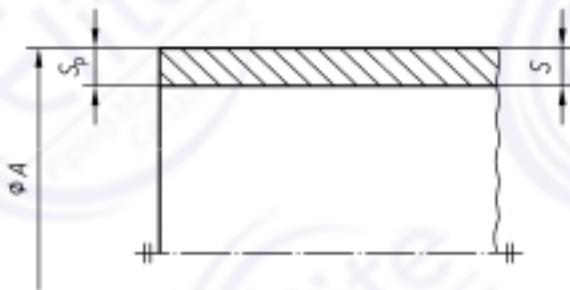

Tolerance of angle:  $+5^\circ$   
 $-0^\circ$

Figure A.6 — Chamfer A for types 36 and 37

Figure A.7 — Chamfer B for types 36 and 37

Table A.3 — Wall thickness for types 36 and 37

$\varnothing A$	PN 2,5 to PN 10				PN 16				Chamfer
	Type 36		Type 37		Type 36		Type 37		
	$S$	$S_p$	$S$	$S_p$	$S$	$S_p$	$S$	$S_p$	
17,2	2	2	2	2	2	2	2	2	A
21,3	2	2	2	2	2	2	2	2	
26,9	2,6	2,6	2	2	2,6	2,6	2	2	
33,7	2,6	2,6	2	2	2,6	2,6	2	2	
42,4	3,2	3,2	2	2	3,2	3,2	2	2	
48,3	3,2	3,2	2	2	3,2	3,2	2	2	
60,3	3,2	3,2	2	2	3,2	3,2	2	2	
76,1	3,2	3,2	2	2	3,2	3,2	2	2	
88,9	3,2	3,2	2	2	3,2	3,2	3,2	3,2	
114,3	3,2	3,2	3,2	3,2	3,2	3,2	3,2	3,2	
139,7	4	3,2	3,2	3,2	4	3,2	3,5	3,2	B
168,3	5	3,2	3,5	3,2	5	3,2	4,5	3,2	
219,1	5	3,2	4,5	3,2	6	3,2	5,6	3,2	
273	8	3,2			10	3,2			
323,9	8	3,2			10	4 <sup>b</sup>			
355,6	8	3,2			10	4 <sup>b</sup>			
406,4	8	3,2			10	4 <sup>b</sup>			
457	8 <sup>a</sup>	3,2 <sup>a</sup>							
508 <sup>a</sup>	8 <sup>a</sup>	3,2 <sup>a</sup>							

<sup>a</sup> These values are valid only for PN 2,5 and PN 6.

<sup>b</sup> Like chamfer B for Type 35.



## Annex B (informative)

### Material groups

The material groups contain materials of similar chemical/mechanical properties and corrosion resistance in order to facilitate an equivalent application of materials in a group depending on pressure, temperature and fluid.

The material groups 1E0 to 6E1 were part of several national standards of CEN Member nations and can be described as follows:

- 1E0 unalloyed structural steels without guaranteed elevated temperature properties, application range -10 °C to +100 °C;
- 1E1 unalloyed structural steels with elevated temperature properties;
- 2E0 unalloyed steels without guaranteed elevated temperature properties;
- 3E0 unalloyed steels with guaranteed elevated temperature properties;
- 3E1 unalloyed steels with specified properties up to 400 °C, upper yield strength > 265 N/mm<sup>2</sup>;
- 4E0 low alloyed steels with 0,3 % molybdenum;
- 5E0 low alloyed steels with 1 % chromium and 0,5 % molybdenum;
- 6E0 low alloyed steels with 2 % chromium and 1 % molybdenum;
- 6E1 alloy steel with 5 % chromium and 0,5 % molybdenum.

The following groups of materials contain steels with low temperature toughness:

- 7E0 low-temperature-tough fine-grain steel with minimum yield strength of 275 N/mm<sup>2</sup> at room temperature;
- 7E1 low-temperature-tough fine-grain steel with minimum yield strength of 355 N/mm<sup>2</sup> at room temperature;
- 7E2 low-temperature nickel alloyed steel (Nickel ≤ 3 %);
- 7E3 low temperature nickel alloyed steel (Nickel > 3 %).

The following groups of materials contain fine-grain steels:

- 8E0 yield strength 225 N/mm<sup>2</sup> min at room temperature;
- 8E2 yield strength 285 N/mm<sup>2</sup> min at room temperature;
- 8E3 yield strength 355 N/mm<sup>2</sup> min at room temperature.

The following groups of materials contain high-temperature-tough ferritic steel

- 9E0 high-temperature-tough ferritic steel with 12 % chromium, 1 % molybdenum and 0,5 % vanadium;
- 9E1 high-temperature-tough ferritic steel with 9 % chromium, 1 % molybdenum and 0,25 % vanadium and 0,1% niobium.

The following groups contain stainless austenitic and austenitic ferritic steels, with differences in corrosion resistance, weld ability and strength, Groups 10E0 up to 12E0 are not alloyed with molybdenum, groups 13E0 to 15E0 are alloyed with molybdenum:

- 10E0 LC-steel;

10E1 LC-steel, nitrogen-alloyed;

11E0 standard carbon-content;

12E0 standard carbon-content, stabilised with Ti resp. Nb;

13E0 LC-steel with molybdenum;

13E1 LC-steel with molybdenum and nitrogen alloyed;

14E0 standard carbon-content alloyed with molybdenum;

15E0 standard carbon-content, alloyed with molybdenum, stabilised with Ti resp. Nb;

16E0 comprise austenitic-ferritic steel.

## Annex C (informative)

### Approximate masses of flanges and collars

Tables C.1 to C.12 give calculated masses of flanges and collars, which may be used for guidance only.

These calculated masses are based on nominal dimensions given in Tables 10 to 21, and on densities of  $7,85 \text{ g/cm}^3$  for steel materials.

The actual masses may vary from the calculated masses due to dimensional variations within the permitted tolerances given in Table 22.

Table C.1 — Masses of flanges PN 2,5

Masses in kilograms

DN	Type 01	Type 05	Type 11	Type 35	Type 36	Type 37
10 to 1 000	Use masses of flanges PN 6/Table C.2					
1 200	—	574	104	56,3	—	—
1 400	—	—	133	—	—	—
1 600	—	—	188	—	—	—
1 800	—	—	215	—	—	—
2 000	—	—	260	—	—	—
2 200	—	—	332	—	—	—
2 400	—	—	392	—	—	—
2 600	—	—	497	—	—	—
2 800	—	—	668	—	—	—
3 000	—	—	772	—	—	—
3 200	—	—	869	—	—	—
3 400	—	—	988	—	—	—
3 600	—	—	1 156	—	—	—
3 800	—	—	1 309	—	—	—
4 000	—	—	1 441	—	—	—

Table C.2 — Masses of flanges PN 6

Masses in kilograms

DN	Type 01	Type 02	Type 05	Type 11	Type 12	Type 32	Type 35	Type 36	Type 37
10	0,356	0,345	0,380	0,353	0,326	0,056	0,08	0,05	0,02
15	0,402	0,388	0,438	0,408	0,373	0,069	0,09	0,06	0,03
20	0,592	0,568	0,657	0,621	0,584	0,108	0,17	0,10	0,06
25	0,719	0,688	0,821	0,762	0,729	0,149	0,26	0,15	0,08
32	1,16	1,12	1,18	1,11	1,04	0,185	0,36	0,26	0,10
40	1,35	1,29	1,39	1,26	1,20	0,244	0,45	0,31	0,13
50	1,48	1,42	1,62	1,43	1,34	0,319	0,53	0,36	0,18
65	1,86	1,76	2,14	1,77	1,83	0,451	0,70	0,47	0,24
80	2,95	2,84	3,43	2,88	2,75	0,606	1,0	0,57	0,42
100	3,26	3,10	4,22	3,41	3,01	0,729	1,3	0,73	0,49
125	4,31	4,12	6,10	4,65	4,30	1,00	1,9	1,20	0,62
150	4,76	4,53	7,51	5,50	4,63	1,01	2,4	1,40	0,71
200	6,88	6,51	12,3	8,60	6,97	1,73	3,9	2,03	1,10
250	8,92	8,32	18,5	11,7	9,13	2,32	5,8	2,65	—
300	11,9	11,1	25,5	15,3	12,4	2,88	6,8	3,12	—
350	16,8	15,9	31,8	20,3	—	4,77	9,5	4,00	—
400	19,8	18,8	38,5	23,1	—	5,83	11,6	4,73	—
450	24,6	23,3	51,2	27,0	—	7,02	15,0	5,30	—
500	26,4	24,9	60,1	30,8	—	8,30	15,9	6,10	—
600	34,8	33,0	103	44,0	—	9,34	23,0	—	—
700	—	—	178	53,7	—	—	30,9	—	—
800	—	—	252	64,4	—	—	41,5	—	—
900	—	—	336	79,2	—	—	50,0	—	—
1 000	—	—	435	98,6	—	—	58,9	—	—
1 200	—	—	717	152	—	—	93,2	—	—
1 400	—	—	1 094	246	—	—	—	—	—
1 600	—	—	1 545	309	—	—	—	—	—
1 800	—	—	2 131	400	—	—	—	—	—
2 000	—	—	2 862	516	—	—	—	—	—
2 200	—	—	—	645	—	—	—	—	—
2 400	—	—	—	786	—	—	—	—	—
2 600	—	—	—	1 021	—	—	—	—	—
2 800	—	—	—	1 256	—	—	—	—	—
3 000	—	—	—	1 404	—	—	—	—	—
3 200	—	—	—	1 617	—	—	—	—	—
3 400	—	—	—	1 877	—	—	—	—	—
3 600	—	—	—	2 366	—	—	—	—	—

Table C.3 — Masses of flanges PN 10

Masses in kilograms

DN	Type 01	Type 02	Type 04	Type 05	Type 11	Type 12	Type 32	Type 34	Type 35	Type 36	Type 37
10	0,604	0,591	0,549	0,722	0,678	0,646	0,094	0,148	0,08	0,05	0,02
15	0,670	0,654	0,606	0,813	0,768	0,722	0,114	0,189	0,09	0,06	0,03
20	0,936	0,909	0,836	1,14	1,09	1,04	0,225	0,340	0,17	0,10	0,06
25	1,11	1,08	0,990	1,38	1,30	1,25	0,296	0,444	0,26	0,15	0,08
32	1,82	1,77	1,65	2,03	1,91	1,81	0,362	0,572	0,36	0,26	0,10
40	2,08	2,02	1,85	2,35	2,15	2,08	0,457	0,734	0,45	0,31	0,13
50	2,73	2,52	2,34	2,88	2,53	2,39	0,653	0,974	0,53	0,36	0,18
65	3,16 <sup>a</sup>	3,05 <sup>a</sup>	2,76 <sup>a</sup>	3,51 <sup>a</sup>	3,03 <sup>a</sup>	2,97 <sup>a</sup>	0,876	1,29	0,70	0,47	0,24
80	3,60	3,48	3,17	4,61	3,92	3,78	1,07	1,67	1,0	0,57	0,42
100	4,39	4,20	3,78	5,65	4,62	4,38	1,28	2,12	1,3	0,73	0,49
125	5,41	5,21	4,57	8,13	6,30	6,07	1,70	2,88	1,9	1,20	0,62
150	7,14	6,89	6,22	10,5	7,81	7,24	1,96	3,46	2,4	1,40	0,71
200	9,27	8,87	7,90	16,5	11,6	10,1	2,81	5,49	3,9	2,03	1,10
250	11,8	11,2	9,99	24,1	15,8	12,8	3,52	7,53	5,8	2,65	—
300	13,6	12,8	11,1	30,8	18,3	14,5	4,02	9,11	6,8	3,12	—
350	20,4	19,4	14,7	39,6	25,3	22,7	7,55	14,1	9,5	4,00	—
400	27,5	26,4	20,5	49,4	30,6	28,0	9,38	17,8	11,6	4,73	—
450	33,6	32,2	25,5	63,0	35,1	32,3	10,3	19,6	15,0	—	—
500	40,2	38,5	30,7	75,2	40,5	38,7	12,6	23,7	15,9	—	—
600	54,5	52,2	43,0	124	52,9	48,9	14,3	28,9	23,0	—	—
700	—	79,4	—	183	75,8	—	—	—	30,9	—	—
800	—	112	—	297	102	—	—	—	41,5	—	—
900	—	135	—	374	121	—	—	—	50,0	—	—
1 000	—	180	—	492	161	—	—	—	58,9	—	—
1 200	—	278	—	842	258	—	—	—	93,2	—	—
1 400	—	—	—	—	371	—	—	—	—	—	—
1 600	—	—	—	—	547	—	—	—	—	—	—
1 800	—	—	—	—	691	—	—	—	—	—	—
2 000	—	—	—	—	830	—	—	—	—	—	—
2 200	—	—	—	—	1 073	—	—	—	—	—	—
2 400	—	—	—	—	1 329	—	—	—	—	—	—
2 600	—	—	—	—	1 574	—	—	—	—	—	—
2 800	—	—	—	—	1 987	—	—	—	—	—	—
3 000	—	—	—	—	2 476	—	—	—	—	—	—

<sup>a</sup> With 8 bolt holes.

Table C.4 — Masses of flanges PN 16

Masses in kilograms

DN	Type 01	Type 02	Type 04	Type 05	Type 11	Type 12	Type 32	Type 34	Type 35	Type 36	Type 37
10	0,604	0,591	0,549	0,722	0,678	0,646	0,094	0,148	0,08	0,05	0,02
15	0,670	0,654	0,606	0,813	0,768	0,722	0,114	0,189	0,09	0,06	0,03
20	0,936	0,909	0,836	1,14	1,09	1,04	0,225	0,340	0,17	0,10	0,06
25	1,11	1,08	0,990	1,38	1,30	1,25	0,296	0,444	0,26	0,15	0,08
32	1,82	1,77	1,65	2,03	1,91	1,81	0,362	0,572	0,36	0,26	0,10
40	2,08	2,02	1,85	2,35	2,15	2,06	0,457	0,734	0,45	0,31	0,13
50	2,73	2,52	2,34	2,88	2,53	2,39	0,653	0,974	0,53	0,36	0,18
65	3,16 <sup>a</sup>	3,05 <sup>a</sup>	2,76 <sup>a</sup>	3,51 <sup>a</sup>	3,03 <sup>a</sup>	2,97 <sup>a</sup>	0,876	1,29	0,70	0,47	0,24
80	3,60	3,48	3,17	4,61	3,92	3,78	1,07	1,67	1,0	0,57	0,42
100	4,39	4,20	3,78	5,65	4,62	4,38	1,28	2,12	1,3	0,73	0,49
125	5,41	5,21	4,57	8,13	6,30	6,07	1,70	2,88	1,9	1,20	0,62
150	7,14	6,89	6,22	10,5	7,81	7,24	1,96	3,46	2,4	1,40	0,71
200	9,73	9,31	8,37	16,2	11,5	9,80	2,81	5,55	3,9	2,03	1,10
250	14,2	13,5	12,4	25,0	16,7	13,6	3,52	7,71	5,8	—	—
300	19,0	18,0	16,3	35,1	22,1	17,2	5,27	11,4	9,5	—	—
350	28,2	27,0	21,5	48,0	32,8	27,9	10,1	19,2	15,2	—	—
400	35,9	34,6	27,1	63,5	41,1	35,7	12,3	23,7	18,7	—	—
450	46,1	44,6	36,7	96,6	50,6	45,0	16,5	28,2	24,4	—	—
500	64,0	62,0	51,1	133	66,2	60,4	21,4	35,5	29,1	—	—
600	102	98,8	78,3	226	104	94,0	28,7	47,9	40,3	—	—
700	—	107	—	285	96,5	—	—	—	45,2	—	—
800	—	152	—	388	122	—	—	—	59,9	—	—
900	—	184	—	483	155	—	—	—	75,6	—	—
1 000	—	257	—	640	233	—	—	—	106,46	—	—
1 200	—	—	—	—	390	—	—	—	—	—	—
1 400	—	—	—	—	495	—	—	—	—	—	—
1 600	—	—	—	—	760	—	—	—	—	—	—
1 800	—	—	—	—	929	—	—	—	—	—	—
2 000	—	—	—	—	1 185	—	—	—	—	—	—

<sup>a</sup> With 8 bolt holes.

Table C.5 — Masses of flanges PN 25

Masses in kilograms

DN	Type 01	Type 02	Type 04	Type 05	Type 11	Type 12	Type 32	Type 34	Type 35
200	14,3	13,8	11,6	22,5	17,1	14,9	4,52	9,07	6,6
250	20,1	19,4	17,0	33,5	24,3	20,9	5,73	12,7	10,0
300	26,6	25,5	22,0	46,3	31,8	27,3	8,42	18,0	15,3
350	41,8	40,5	32,1	68,1	48,8	45,1	14,5	27,8	20,8
400	57,6	56,1	44,5	89,7	63,3	57,7	18,0	36,3	28,6
450	69,8	67,8	54,2	130	76,0	69,6	21,0	40,9	34,4
500	87,0	84,6	65,9	159	97,0	87,0	26,8	55,7	45,8
600	127	124	98,4	278	121	111	34,1	70,5	61,0
700	—	188	—	—	155	—	—	—	—
800	—	259	—	—	205	—	—	—	—
900	—	—	—	—	249	—	—	—	—
1 000	—	—	—	—	338	—	—	—	—

Table C.6 — Masses of flanges PN 40

Masses in kilograms

DN	Type 01	Type 02	Type 04	Type 05	Type 11	Type 12	Type 32	Type 34	Type 35
10	0,604	0,591	0,549	0,722	0,678	0,646	0,094	0,148	0,08
15	0,670	0,654	0,606	0,813	0,768	0,722	0,114	0,189	0,09
20	0,936	0,909	0,836	1,14	1,09	1,04	0,225	0,340	0,17
25	1,11	1,08	0,990	1,38	1,30	1,25	0,296	0,444	0,26
32	1,82	1,77	1,65	2,03	1,91	1,81	0,362	0,572	0,36
40	2,08	2,02	1,85	2,35	2,15	2,06	0,457	0,734	0,45
50	2,73	2,65	2,47	3,20	2,85	2,74	0,653	1,02	0,69
65	3,48	3,36	3,04	4,29	3,68	3,65	0,876	1,36	1,1
80	4,32	4,18	3,61	5,54	4,78	4,59	1,20	1,90	1,6
100	6,07	5,87	5,18	7,60	6,46	6,10	1,58	2,77	2,4
125	8,19	7,95	6,89	10,8	8,86	8,22	2,08	3,78	3,2
150	10,3	9,97	8,69	14,6	11,7	10,6	2,73	5,25	4,6
200	17,9	17,4	14,9	28,8	21,0	18,3	5,55	10,2	8,8
250	29,3	28,4	23,8	44,4	34,2	28,3	7,87	16,4	14,4
300	45,1	43,6	36,0	64,2	47,6	40,4	12,8	25,4	20,7
350	66,7	64,9	50,4	89,5	69,3	58,8	19,3	37,8	30,7
400	97,1	95,1	75,5	127	98	82,1	30,4	56,4	45,4
450	—	—	—	154	105	86,2	28,4	56,4	—
500	—	—	—	188	130	105	35,3	72,9	—
600	—	—	—	331	209	172	53,3	106,000	—

Table C.7 — Masses of flanges PN 63

Masses in kilograms

DN	Type 01	Type 05	Type 11	Type 12
50	4,99	4,52	4,51	4,20
65	4,73	5,69	5,58	5,30
80	5,90	6,89	6,68	6,25
100	8,05	10,0	9,27	8,81
125	11,7	15,9	14,5	13,6
150	16,9	23,3	21,4	19,5
200	30,5	39,2	34,1	—
250	42,1	56,7	48,3	—
300	59,1	81,2	67,5	—
350	88,7	113	97,8	—
400	121	152	129	—

Table C.8 — Masses of flanges PN 100

Masses in kilograms

DN	Type 01	Type 05	Type 11	Type 12
10	1,00	1,04	1,09	1,07
15	1,10	1,16	1,20	1,17
20	1,86	1,97	2,02	1,96
25	2,37	2,54	2,63	2,49
32	2,79	3,07	3,20	2,95
40	3,58	3,97	4,07	3,80
50	4,99	5,64	5,82	5,28
65	6,33	7,44	7,57	6,84
80	7,72	8,85	8,82	7,94
100	10,3	13,3	13,1	11,5
125	17,2	21,3	21,0	17,9
150	23,6	29,4	28,3	23,8
200	42,9	52,7	50,2	—
250	69,0	85,4	81,4	—
300	104	128	118	—
350	150	175	169	—
400	—	—	—	—
500	—	—	—	—



Table C.9 — Masses of flanges PN 160

Masses in kilograms

DN	Type 11
10	1,10
15	1,20
25	2,64
40	4,42
50	6,38
65	8,75
80	10,3
100	15,3
125	24,4
150	34,4
200	60,7
250	97,6
300	140

Table C.10 — Masses of flanges PN 250

Masses in kilograms

DN	Type 11
10	—
15	2,51
25	3,58
40	6,72
50	8,22
65	12,8
80	16,5
100	27,2
125	39,0
150	59,6
200	110
250	190
300	—

**Table C.11 — Masses of flanges PN 320**

Masses in kilograms

DN	Type 11
10	2,14
15	2,53
25	5,18
40	8,65
50	10,7
65	19,5
80	25,2
100	42,5
125	63,6
150	91,5
200	172
250	312

**Table C.12 — Masses of flanges PN 400**

Masses in kilograms

DN	Type 11
10	2,55
15	3,62
25	7,45
40	14,1
50	16,7
65	31,6
80	38,4
100	67,3
125	94,5
150	145
200	270

## Annex D (informative)

### Additional materials

Table D.1 lists, in addition to Table 9, materials which are widely in use, but which are not listed in EN standards. These materials do not have any presumption of conformity if used in pressure equipment under jurisdiction of

Directive 97/23/EC (Pressure Equipment Directive). These materials may be used in pressure equipment according to article 3.3 of the PED (sound engineering practice) or in applications that are not covered by the PED. If they are used in pressure equipment according to categories I to IV according to the PED, they shall have either a

- European Approval of Material (EAM), or
- be covered by a Particular Material Appraisal (PMA).

PMA shall be made by the pressure equipment manufacturer and in categories III and IV it shall have appraisal of the notified body that is responsible for the conformity assessment of the equipment. In the PMA it shall be proved, that the material fulfils the essential safety requirements of the PED.

Table D.1 — Additional materials

Material group <sup>b</sup>	Specification, grade, symbol and material number <sup>a</sup>					
	Castings <sup>o</sup> / seamless tubes <sup>o</sup> / welded pipes <sup>a,d</sup>		Forgings <sup>a,e</sup>		Flat steel products <sup>a,e</sup>	
	Standard	Grade/symbol/ material number	Standard	Grade/symbol/ material number	Standard	Grade/symbol/ material number
1E0	DIN 1681	GS-38	VdTÖV 399/3 <sup>f</sup>	C 21/1.0432	VdTÖV 399/1 <sup>f</sup>	C 21/1.0432
1E1	-	-	EN 10025-2 <sup>h</sup>	S235JR/1.0038	EN 10025-2	S235JR/1.0038
3E0	-	-	VdTÖV 350/3 <sup>f</sup>	C 22.8/1.0460	VdTÖV 350/1 <sup>f</sup>	C 22.8/1.0460
			EN 10222-2	P 250 GH/1.0460	-	-
7E0	-	-	DIN 17103 <sup>g</sup>	TSTE 285/1.0488	DIN 17102 <sup>g</sup>	TSTE 285/1.0488
7E1	DIN 17245	GS-10 NI 19	DIN 17103 <sup>g</sup>	TSTE 355/1.0566	DIN 17102 <sup>g</sup>	TSTE 355/1.0566
-	-	-	DIN 17103 <sup>g</sup>	TSTE 420/1.8912	DIN 17102 <sup>g</sup>	TSTE 420/1.8912
1E0	ASME SA 106	B	-	-	-	-
3E0	-	-	ASME SA 105	-	-	-
3E1	ASME SA 216	WCB	-	-	ASME SA 515	70
	ASME SA 216	WCC			ASME SA 516	70
	ASME SA 333	6			ASME SA 537	CL 1
4E0	ASME SA 217	WC 1	ASME SA 182	F1	ASME SA 204	A
					ASME SA 204	B
5E0	ASME SA 217	WC 6	ASME SA 182	F11 Cl 1, 2 and Cl 3 F12 Cl 1 and 2	ASME SA 387	11
	ASME SA 217	C 5				
	ASME SA 335	P 12				
6E0	ASME SA 217	C 12	ASME SA 182	F 5 F 9 F 22 Cl 1 and 3	ASME SA 387	5
	ASME SA 335	P 5 and P9				9
	ASME SA 335	P 22				22

Table D.1 (continued)

Material group <sup>b</sup>	Specification, grade, symbol and material number <sup>a</sup>					
	Castings <sup>o</sup> / seamless tubes <sup>o</sup> / welded pipes <sup>a,d</sup>		Forgings <sup>a,e</sup>		Flat steel products <sup>a,e</sup>	
	Standard	Grade/symbol/ material number	Standard	Grade/symbol/ material number	Standard	Grade/symbol/ material number
7E3	ASME SA 352	LC 2, LC 3 and LC 8	ASME SA 350	LF 3	ASME SA 203	A E
8E2	-	-	ASME SA 350	LF 2 CI 1 / CI 2	-	-
10E0	ASME SA 351	CF 8	ASME SA 182	F 304	ASME SA 240	304
	ASME SA 312	TP 304 L		F 304 L		304 L
		TP 304		F 304 H		304 H
		TP 304 H				
12E0	ASME SA 312	TP 321 TP 321 H	ASME SA 182	F 321 and 321 H	ASME SA 240	-
14E0	ASME SA 351	CF 8 M	ASME SA 182	F 316	ASME SA 240	316
	ASME SA 312	TP 316		F 316 L		316 L
		TP 316 L		F 316 H		316 H
		TP 316 H				
15E0	-	-	-	-	ASME SA 240	316 TI
16E0	-	-	ASME SA 182	F 51	-	-

<sup>a</sup> Material for bars in all Groups are identical with the material for forgings, ASME Materials see additionally. <sup>b</sup>

<sup>b</sup> The specification of ASME Materials may not be equivalent in all details to the material groups and therefore may not be equally for all applications.

<sup>c</sup> Starting material for the manufacture of flanges. The properties of the resulting flanges may differ from starting material and require to be taken into consideration, so that the resulting flange has adequate properties.

<sup>d</sup> Base material see flat steel products.

<sup>e</sup> Impact properties for RT or low temperature service and guaranteed elevated temperature properties for high temperature service have to be considered.

<sup>f</sup> Material Data Sheet by VdTÜV.

<sup>g</sup> This DIN-materials are listed in particular upon the EN 10222-4 has been revised and provide the corresponding NL-Grades.

<sup>h</sup> Use as forging with the requirements for chemical and mechanical properties of EN 10025-2, hot-rolled structural steel.

## Annex E (normative)

### Basis of flange calculation

#### E.1 General

The calculation of flange union (pair of flanges, bolts and a gasket) according to this standard and the determination of p/t ratings have been carried out as follows:

#### E.2 Calculation method

According to EN 1591-1. Correction for EN 13445-3:2002, Annex G has been applied to Equation (A.1).

#### E.3 Basic rules for calculation of flange connection

##### E.3.1 General

Calculation temperature for all load cases i.e. assembly, testing and operation to determine the standard flange geometrics for the different type of flanges is 20 °C.

To assure that the requirements regarding permissible general membrane stress of the PED are met, flanges have been calculated using the values specified in Annex F, Table F.2.4-1.

**NOTE 1** For nominal design stresses higher than the time-independent design conditions the regulations of the applied design code such as EN 13445 or EN 13480 need to be considered. In any case attention needs to be paid to the effects of temperature.

External loads have been considered. These external loads are calculated by using the following equations

Flange type 01, type 11, type 04 with type 34:

$$F_{R1} = 15 \cdot \pi \cdot (A \cdot S - S^2) / 1000 \quad \text{dimensions } A, S \text{ in mm, } F_{R1} \text{ in kN}$$

$$F_{R2} = \text{Min} (DN; 10 \cdot \sqrt{DN}) \quad F_{R2} \text{ in kN}$$

$$F_R = \text{Max} (F_{R1}; F_{R2})$$

Flange types 32, 35, 36 and 37:

$$F_{R1} = PN \cdot \pi \cdot (DN^2) / 40\,000 \quad \text{dimensions in mm, } F_{R1} \text{ in kN}$$

$$F_{R2} = 5 \cdot \sqrt{DN} \quad F_{R2} \text{ in kN}$$

$$F_R = \text{Min} (F_{R1}; F_{R2})$$

##### E.3.2 Flanges

###### E.3.2.1 Flanges type 11, type 04 with type 34, type 05

- Flange facing: Raised face.
- Height of raised face according to Table 8, depending on DN.
- Corrosions allowance (inner surface): 1,0 mm, for carbon steel, 0,0 mm for stainless steel.

- Tolerances for flange thickness according to Table 22, for machined on front face only.
- Flange material.
- Nominal design stress:
  - at operation 140 MPa;
  - at assembly and testing 200 MPa ( $P_{\text{test}} = 1,43 \times PN$ ).

NOTE That is close to the values of P245GH (forged steel, normally annealed (NG) and 1.4404 (forged steel, solution treated (AT)).

- E-Modulus: 212 000 MPa.
- Mean coefficient of thermal expansion  $\alpha$  ( $10^{-6}/K$ ) = 11,9.

#### E.3.2.2 Flanges types 35, 36 and 37 with type 02

Material values have been similar according to E.3.2.1, but for austenitic steel:

- e-modulus 200 000 MPa;
- mean coefficient of thermal expansion  $\alpha$  ( $10^{-6}/K$ ) = 15,3;
- no corrosion allowance;
- flange facing and tolerances according to E.3.2.1.

#### E.3.2.3 Flanges type 01

- Material values have been similar according to E.3.2.1.
- Pipe nominal thickness has been chosen either according to Table A.1 or to Table A.2.
- Corrosion allowance has been 1 mm to pipe inner surface.

### E.3.3 Pipes

- Dimensional series for the pipe: EN 10216-2, EN 10216-5 and EN 10217-7.
- Pipe wall thickness  $T$  = Mating wall thickness of flange  $S_p$ .
- Consideration of elasticity of the hub especially for large DN.
- Nominal design stress:
  - at operation 140 MPa;
  - at assembly and testing 200 MPa ( $P_{\text{test}} = 1,43 \times PN$ ).
- E-modulus: 212 000 MPa for Carbon steel and 200 000 MPa for Austenitic steel.
- Mean coefficient of thermal expansion  $\alpha$  ( $10^{-6}/K$ ) = 11,9 (CS) and 15,3 (AS).

NOTE The values indicated above are close to those given for P235GH respectively X2CrNiMo17-12-2.

### E.3.4 Bolting/Tightening

- Bolts: Fully threaded screw (Hexagon head bolt) according to EN 4014 with one nut, smooth and lubricated friction coefficient 0,2.

- Bolt material:
  - ≤ M39: nominal design stress at operation 200 MPa, at assembly and testing 285,7 MPa;
  - NOTE That is close to the values of 5.6-bolt
  - > M39: nominal design stress at operation 250 MPa, at assembly and testing 419 MPa.
  - NOTE That is close to the values of 25CrMo4.
- E-modulus: 212 000 MPa.
- Wrenching up to and including M20, torque wrench above M20.
- Scatter value for one single bolt max M20: +/- 0,4 and for bolts larger than M20: ± 0,2.
- Allowed slope of flange plate: 1,0°.
- Bolting strength category acc. EN 1515-2: medium strength.
- Minimum bolt pre-tension rate: Minimum load ratio 0,3.
- Number of assemblies/re-assemblies during lifetime: 20.
- Integral coefficient of thermal expansion  $\alpha$  ( $10^{-6}/K$ ) = 11,9.

### E.3.5 Gasket

- Up to and incl. PN 63: Non-metallic flat gasket, larger DN of PN 63 and higher PN: Spiral wound gasket.
- Gasket dimensions and factors:

	Non-metallic flat gasket	Spiral wound gasket
Dimensions	EN 1514-1	EN 1514-2 <sup>1)</sup>
Thickness	≤ DN 300: = 2 mm > DN 300: = 3 mm	= 4,5 mm
$Q_{min}$	= 25 MPa	= 50 MPa
$Q_{max}$	= 100 MPa	= 300 MPa
$E_0$	= 8 000 MPa	= 10 000 MPa
$K_1$	= 20	= 20
$c_1$	= 0	= 0
$g_c$	= 0,9	= 0,9
$Q/P$ (m)	= 1,6	= 1,6

NOTE 1 The  $Q_{min}$  /  $Q_{max}$  values have only been fixed for the geometrical calculation of the flanges, other values may be used.

NOTE 2 Leakage classes are not considered.

<sup>1)</sup> Dimensions of spiral wound gaskets for flanges type 11 larger than PN 160: Similar to EN 1514-2.

## Annex F (normative)

### Determination of p/t-ratings

#### F.1 General

##### F.1.1 Reference temperature (RT)

A maximum allowable pressure related to the PN number (see 3.2) given in this standard is applicable at the Reference Temperature (RT).

RT is defined as the temperature range from -10 °C up to and including 50 °C.

Up to and including 50°C all flange types are suitable for the given PN. The flanges may be used for temperatures above 50 °C. For this higher temperature the p/t-rating needs to be calculated.

Down to and including -10 °C all materials listed in Table 9 are suitable for a maximum allowable pressure related to the PN number without any further testing than the testing specified in the EN material standard. The materials may be used for lower temperatures. Considerations for prevention of low temperature brittle fracture may be necessary depending on the temperature, the material and heat treatment condition.

**NOTE** The EN product standards (e.g. EN 13445, EN 13480, EN 13458) specify guidance regarding the prevention of low temperature brittle fracture.

##### F.1.2 Application limits and equations

For flanges designated in accordance with 4.2 of this European Standard, the maximum allowable pressure PS calculated at temperature shall not exceed a maximum allowable pressure related to the PN number.

$$PS \leq PN \quad (F.1.2.-1)$$

#### F.2 Symbols, descriptions and units

##### F.2.1 General

For this annex the following symbols are used (see EN 13480-3 for further definition).

Table F.2-1 — Additional symbols for the application of this Annex

Symbols	Description	Unit
$f_t$	Nominal design stress at temperature	MPa (N/mm <sup>2</sup> )
$f_{CR}$	Nominal design stress at the creep range	MPa (N/mm <sup>2</sup> )
$S_{RTt}$	Mean value of creep rupture strength	MPa (N/mm <sup>2</sup> )
$SF_{CR}$	Safety factor which depends on time	-
$v_R$	Reference value for thickness	mm



## F.2.2 p/t-Ratings for materials with time independent nominal design stress

The maximum allowable pressure at temperature is depending on the nominal design stress at temperature in relation to 140 MPa and shall be:

$$PS = PN \times f_t / 140 \text{ MPa} \quad (\text{F.2.2-1})$$

The nominal design stress  $f_t$  shall be determined in accordance with Table F.2.5-1 taking into account the actual value for  $v_R$ .

## F.2.3 p/t-Ratings for materials with time dependent nominal design stress

The maximum allowable pressure at temperature is depending on the lower value of the nominal design stress at temperature and the nominal design stress at creep range in relation to 140 MPa and shall be:

$$PS = PN \times \min (f_t; f_{CR}) / 140 \text{ MPa} \quad (\text{F.2.3-1})$$

The nominal design stresses  $f_t$  and  $f_{CR}$  shall be determined in accordance with Table F.2.5-1 and Table F.2.5-2 taking into account the actual value for  $v_R$ .

## F.2.4 Reference value for thickness ( $v_R$ )

EN material standards are specifying strength values depending on different ranges of product thicknesses. The thickness related material values shall be used in calculation.

$v_R$  shall be the upper thickness of each nominal thickness range for which a material strength value ( $R_{eH}$ ,  $R_p$ ,  $R_m$  as appropriate) is given in the material standard. The calculation results of equations F.2.2-1 and F.2.3-1 shall be valid for all flanges of this European Standard provided:

- the flanges are made of material with the same or higher material values as the values used for the calculation and
- nominal flange thickness is less or equal to  $v_R$

For material with different  $v_R$ , the p/t-rating can be given for each  $v_R$ .

**NOTE 1** The p/t-ratings are to be built by a comparison of a material related term ( $f_t$ ;  $f_{CR}$ ) and the value of 140 MPa to  $PN$ .  $f_t$ ;  $f_{CR}$  are a function of the material thickness for a given material. To compare the results of F.2.1-1 and F.2.2-1 with the thickness of a flange according to this European Standard,  $v_R$  is introduced in this European Standard.

**NOTE 2** It is the intention of this annex to provide rules for determination of p/t-ratings on a simplified procedure. But it should also be possible to use comparable higher mechanical properties for different thicknesses of base material if this covers the majority of flanges in use.

## F.2.5 Nominal design stresses and safety factors for mean creep rupture strength

The nominal design stresses shall be based on strength values specified in the material standard. The nominal design stresses shall be calculated as shown in Table F.2.5-1. Guidance on safety factors as a function of mean creep rupture strength related to time is given in Table F.2.5-2.

Linear interpolation of strength values between two adjacent temperature values shall be applied for temperatures above 50 °C (e.g. for 80 °C between 20 °C and 100 °C; for 120 °C between 100 °C and 150 °C).

Table F.2.5-1 — Nominal design stresses

Material group	Nominal design stress at Temperature / Nominal design stress at the creep range
3E0 to 9E1 and 16E0	$f = \min ((R_{eHt} / 1,5 \text{ or } R_{p0,2t} / 1,5; R_m / 2,4); S_{RT} / SF_{CR})$
10E0 to 15E0 (for $30 \leq A \leq 35\%$ ) <sup>a</sup>	$f = \min ((R_{p1,0t} / 1,5; R_m / 2,4); S_{RT} / SF_{CR})$
10E0 to 15E0 (for A above 35%) <sup>a</sup>	$f = \min ((R_{p1,0t} / 1,5) \text{ or } \min (R_{p1,0t} / 1,2; R_{m} / 3)^b; S_{RT} / SF_{CR})$
2E0 to 4E0, 7E0, 7E1 (castings)	$f = \min (R_{p0,2t} / 1,9)$
5E0, 6E0, 9E0 (castings)	$f = \min (R_m / 3,0)$
10E0 to 15E0 (castings)	$f = \min (R_{p1,0t} / 1,9)$
<sup>a</sup> A = Elongation after rupture	
<sup>b</sup> If $R_{m}$ is available	

Table F.2.5-2 — Safety factors for mean creep rupture strength

Time T in h	Safety factor $SF_{CR}$
200 000	1,25
150 000	1,35
100 000	1,5

NOTE Data of both tables are derived from EN 13480-3. See EN 13480-3 for further definition.

### F.2.6 Flanges made from steel castings

For flanges made from steel casting (types no. 21, 34) the actual dimension needs to be calculated to comply with the p/t-ratings for steel forging / flat product.

The calculation shall also be done under the rules of the component or equipment standard applicable for the component or pressure equipment of which this flange is an integral part (e.g. EN 12516 for valves).

All mating dimensions, the neck diameter (N3) and (minimum) flange wall thickness shall be as given in Tables 10 to 21.

NOTE For flanges type 21 see footnote a of Table 6 and NOTE 5 of 5.6.1.

### F.2.7 Rounding of maximum allowable pressure at temperature

The results of calculated maximum allowable pressure PS at temperature (according to F.2.2-1 respectively F.2.3-1) shall be rounded downwards to the first decimal place (e.g. value of 15,09 bar rounded downwards to 15,0 bar; or 15,19 bar rounded downwards to 15,1 bar).

## Annex G (normative)

### p/t-ratings for a selection of EN materials

#### G.1 General

##### G.1.1 p/t-ratings

A range of p/t-ratings for a selection of commonly used EN materials is indicated in this annex. These p/t-ratings are prepared to support the user of this European Standard and shall not be understood either as a limitation in p/t-ratings nor materials. If the user of this European Standard has the need to determine his own p/t-rating for a certain application this can be done under consideration of the basic rules to determine a p/t-rating (see Annex F).

##### G.1.2 Basics of determination of p/t-ratings (see Annex F)

p/t-ratings are calculated by using the equations F.2.2-1 and F.2.3-2.

In compliance with Equation F.2-1, the calculated pressure values do not exceed PN.

Strength values for steel forgings, flat steel products and steel castings are taken from EN material standards considering the different range of product thickness. For provisions regarding the reference value for thickness  $v_R$  see F.2.4.

p/t-ratings are calculated by using the strength values of steel forgings depending on different range of product thickness and are verified for flat steel products of the same group.

Nominal design stresses are calculated by using the equations as defined in Table F.2.5-1.

Interpolation rules as defined in Annex F have been applied.

NOTE 1 The graduation of  $v_R$  depends from the product of material from which a flange is manufactured. For the different methods of fabrication see Table 1 of this European Standard.

NOTE 2 For flanges made from steel casting (type 21) see footnote a of Table 6 and definitions stated in F.2.6.

NOTE 3 If the flange joint consists of materials with different strength properties (excluding bolts), p/t-ratings need to be chosen in accordance with the lowest strength values.

NOTE 4 The p/t-ratings are to be built by a comparison of a material related term ( $f_{t,CR}$ ) and the value of 140 MPa to PN.  $f_{t,CR}$  are a function of the material thickness for a given material. To compare the results of F.2.2-1 and F.2.3-1 with the thickness of a flange of this European Standard  $v_R$  is introduced in this European Standard.

##### G.1.3 Application limits for creep range

Materials marked with an "X" have been calculated using 100 000 h creep rupture strength values as given in EN material standards under consideration of the safety factor  $SF_{CR}$  as indicated in Table F.2.5-2.

The application of creep range within the p/t-ratings listed is limited up to and including 600 °C. This limit should be understood as a practical application limit and not as a restriction in use. If there is a need to extend this application limit to higher temperatures than 600 °C this can be done by individual calculations provided mean creep rupture strength values are given in EN material standards.

## G.2 Non-austenitic steels

### G.2.1 General

p/t-ratings are given in Tables G.2.1-1 to G.2.1-12 for non-austenitic steels. They are calculated by using the strength values of steel forgings (see Table G.1.1-1) and are verified for flat steel products of the same group (see Table 9) up to and including 800 °C. Thickness related strength values for all thicknesses up to and including 150 mm have been considered, except for material 1.4903 where  $v_R \leq 130$  mm.

p/t-ratings are calculated by using the strength values of steel forgings and are verified for flat steel products of the same group (see notes in Table G.1.1-1).

100 000 h creep rupture strength values are considered for materials marked with 'X' in Table G.1.1-1.

Maximum allowable pressures at temperatures for which 100 000 h creep have been considered are indicated in italic letters in Tables G.2.1-1 to G.2.1-12.

For flanges made from steel castings (type 21; material selection see Table 9) the p/t-ratings shall be the same as for the corresponding steel forgings respectively flat steel products (see Table 9). The wall thicknesses need to be verified (see provisions made in F.2.5).

NOTE For nominal design stress values of steel castings it may be necessary to consider the provisions given in applicable component or equipment standards (e.g. EN 12516).

## G.2.2 List of materials

Table G.1.1-1 — Non-austenitic materials

Group	Material	Material No.	EN	R <sub>p0,2t</sub>	Creep	Notes
3E0	P245GH	1.0352	10222-2	R <sub>p0,2t</sub>	X	
3E1	P280GH	1.0426	10222-2	R <sub>p0,2t</sub>	X	
4E0	16Mo3	1.5415	10222-2	R <sub>p0,2t</sub>	X	
5E0	13CrMo4-5	1.7335	10222-2	R <sub>p0,2t</sub>	X	
6E0	11CrMo9-10	1.7383	10222-2	R <sub>p0,2t</sub>	X	
6E1	X16CrMo5-1+NT	1.7386	10222-2	R <sub>p0,2t</sub>	X	
7E0	13MnNi6-3	1.6217	10222-3	R <sub>p0,2t</sub>	—	f
7E1	P355 NL1, P355 NL2	1.0566 1.1106	10028-3	R <sub>p0,2t</sub>	—	a, g
7E2	15NiMn6	1.6228	10222-3	R <sub>p0,2t</sub>	—	f
7E3	12Ni14	1.5637	10222-3	R <sub>p0,2t</sub>	—	f
7E2	X8Ni9	1.5662	10222-3	R <sub>p0,2t</sub>	—	f
8E2	P285NH	1.0487	10222-4	R <sub>p0,2t</sub>	—	c, d
8E3	P355NH	1.0565	10222-4	R <sub>p0,2t</sub>	—	b, d, e
9E0	X20CrMoV11-1	1.4922	10222-2	R <sub>p0,2t</sub>	X	
9E1	X10CrMoVNb9-1	1.4903	10222-2	R <sub>p0,2t</sub>	X	

NOTE Table contains a selection of commonly used non-austenitic materials.

<sup>a</sup> Refer to Annex D for steel forgings corresponding to this low-temperature-tough fine-grain steel.

<sup>b</sup> p/t-ratings can also be used for material group 7E1 under conditions (see EN 10028-3).

<sup>c</sup> For all thicknesses of up to and including 70 mm the strength values for temperatures above 50 °C for a thickness range  $35 < v_R \leq 70$  have been used for calculation of p/t-ratings.

<sup>d</sup> For all thicknesses up to and including 150 mm for strength values for temperatures above 50 °C lower strength values either of EN 10028-3 or EN 10222-4 has been used.

<sup>e</sup> For all thicknesses of up to and including 100 mm the strength values for temperatures above 50 °C for a thickness range  $50 < v_R \leq 100$  have been used for calculation of p/t-ratings.

<sup>f</sup> Material groups 7E0, 7E2; no separate p/t-ratings are listed, because of the reason that no strength values for temperatures above 50 °C are given by the related EN standards EN 10222-3 and EN 10028-4.

<sup>g</sup> No separate p/t-ratings are listed, since the strength values are the same as for the NH-grade.

EN 1092-1:2007 (E)

G.2.3 p/t-Ratings

Table G.2.1-1 — PN 2,5

PN	Group	$r_n$ (mm)	max. allowable temperature TS °C																							
			RT	100	150	200	250	300	350	400	450	460	470	480	490	500	510	520	530	540	550	560	570	580	590	600
			max. allowable pressure PS bar																							
2,5	3E0	$\leq 50$	2,5	2,3	2,2	2,0	1,9	1,7	1,6	1,4	0,8															
	3E0	$50 < r_n \leq 150$	2,5	2,1	2,0	1,9	1,7	1,6	1,5	1,4	0,8															
	3E1	$\leq 50$	2,5	2,5	2,5	2,5	2,4	2,2	2,0	1,8	1,0															
	3E1	$50 < r_n \leq 150$	2,5	2,5	2,3	2,2	2,0	1,9	1,7	1,6	1,0															
	4E0	$\leq 80$	2,5	2,5	2,5	2,5	2,4	2,1	2,0	1,8	1,7	1,6	1,4	1,3	1,2	1,1	0,8	0,7	0,5							
	4E0	$80 < r_n \leq 90$	2,5	2,5	2,5	2,5	2,3	2,0	1,9	1,7	1,6	1,5	1,4	1,3	1,2	1,1	0,8	0,7	0,5							
	4E0	$90 < r_n \leq 150$	2,5	2,5	2,5	2,3	2,1	1,9	1,7	1,5	1,4	1,4	1,3	1,2	1,1	1,1	0,8	0,7	0,5							
	5E0	$\leq 80$	2,5	2,5	2,5	2,5	2,5	2,5	2,3	2,2	2,1	2	1,9	1,8	1,7	1,6	1,3	1,1	0,9	0,7	0,5	0,4	0,3			
	5E0	$80 < r_n \leq 90$	2,5	2,5	2,5	2,5	2,5	2,4	2,2	2,0	1,9	1,8	1,8	1,7	1,6	1,6	1,3	1,1	0,9	0,7	0,5	0,4	0,3			
	5E0	$90 < r_n \leq 150$	2,5	2,5	2,5	2,5	2,5	2,2	2,1	1,9	1,8	1,7	1,7	1,6	1,6	1,6	1,3	1,1	0,9	0,7	0,5	0,4	0,3			
	6E0	$\leq 150$	2,5	2,5	2,5	2,5	2,5	2,5	2,4	2,3	2,2	2,0	1,9	1,8	1,7	1,6	1,4	1,2	1,0	0,9	0,8	0,6	0,6	0,5	0,4	0,4
	6E1	$\leq 150$	2,5	2,5	2,5	2,5	2,5	2,5	2,5	2,5	2,5	2,5	2,5	2,1	1,7	1,3	1,1	0,9	0,8	0,7	0,5	0,5	0,4			
	6E2	$35 < r_n \leq 70$	2,5	2,5	2,5	2,3	2,1	1,8	1,6	1,4																
	6E2	$70 < r_n \leq 100$	2,5	2,5	2,3	2,1	1,9	1,6	1,4	1,1																
	6E2	$100 < r_n \leq 150$	2,5	2,4	2,2	1,9	1,7	1,4	1,1	0,9																
	6E3	$50 < r_n \leq 100$	2,5	2,5	2,5	2,5	2,5	2,4	2,2	1,9																
	6E3	$100 < r_n \leq 150$	2,5	2,5	2,5	2,5	2,5	2,3	2,1	1,7																
	9E0	$\leq 150$	2,5	2,5	2,5	2,5	2,5	2,5	2,5	2,5	2,5	2,5	2,5	2,5	2,5	2,5	2,5	2,2	1,9	1,7	1,5	1,3	1,1	0,9	0,8	0,7
	9E1	$\leq 130$	2,5	2,5	2,5	2,5	2,5	2,5	2,5	2,5	2,5	2,5	2,5	2,5	2,5	2,5	2,5	2,5	2,3	2,1	1,9	1,7	1,5	1,4	1,2	1,1

Table G.2.1-2 — PN 6

PN	Group	r <sub>s</sub> (mm)	max. allowable temperature TS °C																							
			RT	100	150	200	250	300	350	400	450	460	470	480	490	500	510	520	530	540	550	560	570	580	590	600
			max. allowable pressure PS bar																							
6	3E0	≤ 50	6,0	5,5	5,2	5	4,5	4,1	3,8	3,5	1,9															
	3E0	50 < r <sub>s</sub> ≤ 150	6,0	5,1	5	4,6	4,2	3,8	3,6	3,4	1,9															
	3E1	≤ 50	6,0	6,0	6,0	6,0	5,8	5,2	4,8	4,4	2,4															
	3E1	50 < r <sub>s</sub> ≤ 150	6,0	6,0	5,7	5,4	5,0	4,6	4,2	3,8	2,4															
	4E0	≤ 60	6,0	6,0	6,0	6,0	5,8	5,1	4,8	4,4	4,1	3,8	3,5	3,2	2,9	2,6	2,1	1,6	1,3							
	4E0	60 < r <sub>s</sub> ≤ 90	6,0	6,0	6,0	6,0	5,5	4,8	4,5	4,1	3,8	3,6	3,3	3,1	2,8	2,6	2,1	1,6	1,3							
	4E0	90 < r <sub>s</sub> ≤ 150	6,0	6,0	6,0	5,5	5,1	4,5	4,2	3,8	3,5	3,3	3,1	3,0	2,8	2,6	2,1	1,6	1,3							
	5E0	≤ 60	6,0	6,0	6,0	6,0	6,0	6,0	5,7	5,4	5,0	4,8	4,5	4,3	4,0	3,9	3,3	2,6	2,2	1,7	1,4	1,1	0,9			
	5E0	60 < r <sub>s</sub> ≤ 90	6,0	6,0	6,0	6,0	6,0	5,8	5,4	5,0	4,7	4,5	4,3	4,1	3,9	3,9	3,3	2,6	2,2	1,7	1,4	1,1	0,9			
	5E0	90 < r <sub>s</sub> ≤ 150	6,0	6,0	6,0	6,0	6,0	5,5	5,0	4,7	4,4	4,2	4,1	4,0	3,9	3,9	3,3	2,6	2,2	1,7	1,4	1,1	0,9			
	6E0	≤ 150	6,0	6,0	6,0	6,0	6,0	6,0	5,8	5,5	5,2	5,0	4,7	4,4	4,1	3,8	3,3	2,9	2,5	2,2	1,9	1,6	1,4	1,2	1,0	0,9
	6E1	≤ 150	6,0	6,0	6,0	6,0	6,0	6,0	6,0	6,0	6,0	6,0	6,0	5,0	4,1	3,2	2,7	2,3	2,0	1,6	1,4	1,2	1,0			
	8E2	35 < r <sub>s</sub> ≤ 70	6,0	6,0	6,0	5,6	5,1	4,4	3,9	3,3																
	8E2	70 < r <sub>s</sub> ≤ 100	6,0	6,0	5,6	5,2	4,7	3,9	3,3	2,8																
	8E2	100 < r <sub>s</sub> ≤ 150	6,0	5,8	5,3	4,7	4,2	3,3	2,8	2,2																
	8E3	50 < r <sub>s</sub> ≤ 100	6,0	6,0	6,0	6,0	6,0	5,8	5,4	4,7																
	8E3	100 < r <sub>s</sub> ≤ 150	6,0	6,0	6,0	6,0	6,0	5,6	5,0	4,2																
	9E0	≤ 150	6,0	6,0	6,0	6,0	6,0	6,0	6,0	6,0	6,0	6,0	6,0	6,0	6,0	6,0	6,0	5,3	4,7	4,2	3,6	3,1	2,7	2,3	1,9	1,6
	9E1	≤ 130	6,0	6,0	6,0	6,0	6,0	6,0	6,0	6,0	6,0	6,0	6,0	6,0	6,0	6,0	6,0	6,0	5,7	5,2	4,7	4,2	3,8	3,4	3,0	2,6

EN 1092-1:2007 (E)

Table G.2.1-3 — PN 10

PN	Group	$r_n$ (mm)	max. allowable temperature TS °C																									
			RT	100	150	200	250	300	350	400	450	460	470	480	490	500	510	520	530	540	550	560	570	580	590	600		
			max. allowable pressure PS bar																									
10	3E0	$\leq 50$	10,0	9,2	8,8	8,3	7,6	6,9	6,4	5,9	3,2																	
	3E0	$50 < r_n \leq 150$	10,0	8,5	8,3	7,7	7,0	6,4	6,0	5,7	3,2																	
	3E1	$\leq 50$	10,0	10,0	10,0	10,0	9,7	8,8	8,0	7,3	4,0																	
	3E1	$50 < r_n \leq 150$	10,0	10,0	9,5	9,0	8,3	7,6	7,0	6,4	4,0																	
	4E0	$\leq 60$	10,0	10,0	10,0	10,0	9,7	8,5	8,0	7,4	6,9	6,4	5,9	5,4	4,9	4,4	3,5	2,8	2,2									
	4E0	$60 < r_n \leq 90$	10,0	10,0	10,0	10,0	9,2	8,0	7,6	6,9	6,4	6,0	5,6	5,2	4,8	4,4	3,5	2,8	2,2									
	4E0	$90 < r_n \leq 150$	10,0	10,0	10,0	9,2	8,5	7,6	7,0	6,3	5,9	5,6	5,3	5,0	4,7	4,4	3,5	2,8	2,2									
	5E0	$\leq 60$	10,0	10,0	10,0	10,0	10,0	10,0	9,5	9,0	8,4	8,0	7,6	7,2	6,8	6,5	5,5	4,4	3,7	2,9	2,3	1,9	1,5					
	5E0	$60 < r_n \leq 90$	10,0	10,0	10,0	10,0	10,0	9,7	9,0	8,3	7,8	7,5	7,2	6,9	6,6	6,5	5,5	4,4	3,7	2,9	2,3	1,9	1,5					
	5E0	$90 < r_n \leq 150$	10,0	10,0	10,0	10,0	10,0	9,1	8,4	7,9	7,3	7,1	6,9	6,7	6,5	6,5	5,5	4,4	3,7	2,9	2,3	1,9	1,5					
	6E0	$\leq 150$	10,0	10,0	10,0	10,0	10,0	10,0	9,7	9,2	8,8	8,3	7,8	7,3	6,9	6,4	5,6	4,9	4,2	3,7	3,2	2,7	2,4	2,0	1,8	1,6		
	6E1	$\leq 150$	10,0	10,0	10,0	10,0	10,0	10,0	10,0	10,0	10,0	10,0	10,0	8,4	6,9	5,3	4,5	3,8	3,3	2,8	2,3	2,0	1,7					
	8E2	$35 < r_n \leq 70$	10,0	10,0	10,0	9,3	8,6	7,4	6,5	5,6																		
	8E2	$70 < r_n \leq 100$	10,0	10,0	9,4	8,6	7,9	6,5	5,6	4,6																		
	8E2	$100 < r_n \leq 150$	10,0	9,7	8,8	7,9	7,0	5,6	4,6	3,7																		
	8E3	$50 < r_n \leq 100$	10,0	10,0	10,0	10,0	10,0	9,8	9,0	7,9																		
	8E3	$100 < r_n \leq 150$	10,0	10,0	10,0	10,0	10,0	9,3	8,4	7,0																		
	9E0	$\leq 150$	10,0	10,0	10,0	10,0	10,0	10,0	10,0	10,0	10,0	10,0	10,0	10,0	10,0	10,0	10,0	8,9	7,9	7,0	6,0	5,2	4,5	3,8	3,2	2,8		
	9E1	$\leq 130$	10,0	10,0	10,0	10,0	10,0	10,0	10,0	10,0	10,0	10,0	10,0	10,0	10,0	10,0	10,0	10,0	9,5	8,7	7,9	7,1	6,3	5,7	5,0	4,4		



Table G.2.1-4 — PN 16

PN	Group	$r_h$ (mm)	max. allowable temperature TS °C																							
			RT	100	150	200	250	300	350	400	450	460	470	480	490	500	510	520	530	540	550	560	570	580	590	600
			max. allowable pressure PS bar																							
16	3E0	$\leq 50$	16,0	14,8	14	13,3	12,1	11	10,2	9,5	5,2															
	3E0	$50 < r_h \leq 150$	16,0	13,7	13,3	12,4	11,3	10,2	9,6	9,1	5,2															
	3E1	$\leq 50$	16,0	16,0	16	16	15,6	14	12,9	11,8	6,4															
	3E1	$50 < r_h \leq 150$	16,0	16,0	15,2	14,5	13,3	12,2	11,3	10,2	6,4															
	4E0	$\leq 60$	16,0	16,0	16,0	16,0	15,6	13,7	12,9	11,9	11,0	10,2	9,4	8,6	7,8	7,0	5,6	4,4	3,5							
	4E0	$60 < r_h \leq 90$	16,0	16,0	16,0	16,0	14,8	12,9	12,1	11,1	10,2	9,6	9,0	8,3	7,7	7,0	5,6	4,4	3,5							
	4E0	$90 < r_h \leq 150$	16,0	16,0	16,0	14,8	13,7	12,1	11,2	10,1	9,4	8,9	8,5	8,0	7,5	7,0	5,6	4,4	3,5							
	5E0	$\leq 60$	16,0	16,0	16,0	16,0	16,0	16,0	15,2	14,4	13,4	12,8	12,1	11,5	10,8	10,4	8,8	7,1	5,9	4,6	3,7	3,0	2,5			
	5E0	$60 < r_h \leq 90$	16,0	16,0	16,0	16,0	16,0	15,6	14,4	13,4	12,5	12	11,5	11	10,5	10,4	8,8	7,1	5,9	4,6	3,7	3,0	2,5			
	5E0	$90 < r_h \leq 150$	16,0	16,0	16,0	16,0	16,0	14,7	13,5	12,7	11,8	11,4	11,1	10,7	10,4	10,4	8,8	7,1	5,9	4,6	3,7	3,0	2,5			
	6E0	$\leq 150$	16,0	16,0	16,0	16,0	16,0	16,0	15,6	14,8	14,0	13,3	12,5	11,8	11,0	10,2	8,9	7,8	6,8	5,9	5,1	4,4	3,8	3,3	2,8	2,5
	6E1	$\leq 150$	16,0	16,0	16,0	16,0	16,0	16,0	16,0	16,0	16,0	16,0	16,0	13,5	11,0	8,6	7,3	6,1	5,3	4,4	3,8	3,2	2,8			
	8E2	$35 < r_h \leq 70$	16,0	16,0	16,0	15,0	13,7	11,9	10,4	8,9																
	8E2	$70 < r_h \leq 100$	16,0	16,0	15,0	13,8	12,7	10,4	8,9	7,4																
	8E2	$100 < r_h \leq 150$	16,0	15,6	14,1	12,7	11,2	8,9	7,4	5,9																
	8E3	$50 < r_h \leq 100$	16,0	16,0	16,0	16,0	16,0	15,6	14,4	12,7																
	8E3	$100 < r_h \leq 150$	16,0	16,0	16,0	16,0	16,0	14,9	13,4	11,2																
	9E0	$\leq 150$	16,0	16,0	16,0	16,0	16,0	16,0	16,0	16,0	16,0	16,0	16,0	16,0	16,0	16,0	16,0	14,3	12,7	11,2	9,7	8,4	7,2	6,1	5,2	4,4
	9E1	$\leq 130$	16,0	16,0	16,0	16,0	16,0	16,0	16,0	16,0	16,0	16,0	16,0	16,0	16,0	16,0	16,0	16,0	15,3	13,9	12,6	11,4	10,2	9,1	8,0	7,1

Table G.2.1-5 — PN 25

PN	Group	$r_n$ (mm)	max. allowable temperature TS °C																								
			RT	100	150	200	250	300	350	400	450	460	470	480	490	500	510	520	530	540	550	560	570	580	590	600	
			max. allowable pressure PS bar																								
25	3E0	$\leq 50$	25,0	23,2	22,0	20,8	19,0	17,2	16,0	14,8	8,2																
	3E0	$50 < r_n \leq 150$	25,0	21,4	20,8	19,4	17,7	16,0	15,1	14,2	8,2																
	3E1	$\leq 50$	25,0	25,0	25,0	25,0	24,4	22,0	20,2	18,4	10,1																
	3E1	$50 < r_n \leq 150$	25,0	25,0	23,8	22,7	20,8	19,1	17,7	16,0	10,1																
	4E0	$\leq 60$	25,0	25,0	25,0	25,0	24,4	21,4	20,2	18,6	17,2	16,0	14,7	13,5	12,3	11,0	8,8	7,0	5,5								
	4E0	$60 < r_n \leq 90$	25,0	25,0	25,0	25,0	23,2	20,2	19,0	17,3	16,0	15,0	14,0	13,0	12,0	11,0	8,8	7,0	5,5								
	4E0	$90 < r_n \leq 150$	25,0	25,0	25,0	23,2	21,4	19,0	17,5	15,8	14,7	14,0	13,2	12,5	11,8	11,0	8,8	7,0	5,5								
	5E0	$\leq 80$	25,0	25,0	25,0	25,0	25,0	25,0	23,8	22,5	21,0	20,0	19,0	18,0	17,0	16,3	13,8	11,1	9,2	7,2	5,8	4,7	3,9				
	5E0	$60 < r_n \leq 90$	25,0	25,0	25,0	25,0	25,0	24,4	22,5	20,9	19,6	18,8	18,0	17,2	16,5	16,3	13,8	11,1	9,2	7,2	5,8	4,7	3,9				
	5E0	$90 < r_n \leq 150$	25,0	25,0	25,0	25,0	25,0	22,9	21,1	19,8	18,4	17,9	17,3	16,8	16,2	16,3	13,8	11,1	9,2	7,2	5,8	4,7	3,9				
	6E0	$\leq 150$	25,0	25,0	25,0	25,0	25,0	25,0	24,4	23,2	22,0	20,8	19,6	18,4	17,2	16,0	14,0	12,2	10,7	9,2	8,0	6,9	6,0	5,2	4,5	4,0	
	6E1	$\leq 150$	25,0	25,0	25,0	25,0	25,0	25,0	25,0	25,0	25,0	25,0	25,0	21,2	17,3	13,4	11,4	9,6	8,3	7,0	5,9	5,1	4,4				
	8E2	$35 < r_n \leq 70$	25,0	25,0	25,0	23,4	21,5	18,6	16,3	14,0																	
	8E2	$70 < r_n \leq 100$	25,0	25,0	23,5	21,6	19,8	16,3	14,0	11,6																	
	8E2	$100 < r_n \leq 150$	25,0	24,4	22,1	19,8	17,5	14,0	11,6	9,2																	
	8E3	$50 < r_n \leq 100$	25,0	25,0	25,0	25,0	25,0	24,5	22,6	19,8																	
	8E3	$100 < r_n \leq 150$	25,0	25,0	25,0	25,0	25,0	23,3	21,0	17,5																	
	9E0	$\leq 150$	25,0	25,0	25,0	25,0	25,0	25,0	25,0	25,0	25,0	25,0	25,0	25,0	25,0	25,0	25,0	22,3	19,8	17,5	15,2	13,2	11,3	9,6	8,2	7,0	
	9E1	$\leq 130$	25,0	25,0	25,0	25,0	25,0	25,0	25,0	25,0	25,0	25,0	25,0	25,0	25,0	25,0	25,0	25,0	23,9	21,7	19,7	17,8	15,9	14,2	12,6	11,1	

Table G.2.1-6 — PN 40

PN	Group	$r_h$ (mm)	max. allowable temperature TS °C																							
			RT	100	150	200	250	300	350	400	450	460	470	480	490	500	510	520	530	540	550	560	570	580	590	600
			max. allowable pressure PS bar																							
40	3E0	$\leq 50$	40,0	37,1	35,2	33,3	30,4	27,6	25,7	23,8	13,1															
	3E0	$50 < r_h \leq 150$	40,0	34,2	33,3	31,0	28,3	25,7	24,1	22,8	13,1															
	3E1	$\leq 50$	40,0	40,0	40,0	40,0	39,0	35,2	32,3	29,5	16,1															
	3E1	$50 < r_h \leq 150$	40,0	40,0	38,0	36,3	33,3	30,6	28,3	25,7	16,1															
	4E0	$\leq 60$	40,0	40,0	40,0	40,0	39,0	34,2	32,3	29,9	27,6	25,6	23,6	21,6	19,7	17,7	14,0	11,2	8,9							
	4E0	$60 < r_h \leq 90$	40,0	40,0	40,0	40,0	37,1	32,3	30,4	27,8	25,7	24,1	22,5	20,9	19,3	17,7	14,0	11,2	8,9							
	4E0	$90 < r_h \leq 150$	40,0	40,0	40,0	37,1	34,2	30,4	28,0	25,3	23,6	22,4	21,2	20,0	18,9	17,7	14,0	11,2	8,9							
	5E0	$\leq 60$	40,0	40,0	40,0	40,0	40,0	40,0	38,0	36,0	33,7	32,0	30,4	28,8	27,2	26,0	22,0	17,9	14,8	11,6	9,3	7,6	6,2			
	5E0	$60 < r_h \leq 90$	40,0	40,0	40,0	40,0	40,0	39,0	36,0	33,5	31,4	30,1	28,9	27,6	26,4	26,0	22,0	17,9	14,8	11,6	9,3	7,6	6,2			
	5E0	$90 < r_h \leq 150$	40,0	40,0	40,0	40,0	40,0	36,7	33,9	31,8	29,5	28,6	27,7	26,8	26,0	26,0	22,0	17,9	14,8	11,6	9,3	7,6	6,2			
	6E0	$\leq 150$	40,0	40,0	40,0	40,0	40,0	40,0	39,0	37,1	35,2	33,3	31,4	29,5	27,6	25,7	22,4	19,6	17,1	14,8	12,9	11,0	9,7	8,3	7,2	6,4
	6E1	$\leq 150$	40,0	40,0	40,0	40,0	40,0	40,0	40,0	40,0	40,0	40,0	40,0	33,9	27,7	21,5	18,2	15,4	13,3	11,2	9,5	8,1	7,0			
	8E2	$35 < r_h \leq 70$	40,0	40,0	40,0	37,5	34,4	29,9	26,0	22,4																
	8E2	$70 < r_h \leq 100$	40,0	40,0	37,7	34,6	31,8	26,0	22,4	18,6																
	8E2	$100 < r_h \leq 150$	40,0	39,0	35,4	31,8	28,0	22,4	18,6	14,8																
	8E3	$50 < r_h \leq 100$	40,0	40,0	40,0	40,0	40,0	39,2	36,1	31,8																
	8E3	$100 < r_h \leq 150$	40,0	40,0	40,0	40,0	40,0	37,3	33,7	28,0																
	9E0	$\leq 150$	40,0	40,0	40,0	40,0	40,0	40,0	40,0	40,0	40,0	40,0	40,0	40,0	40,0	40,0	40,0	35,8	31,8	28,0	24,3	21,1	18,0	15,4	13,1	11,2
	9E1	$\leq 130$	40,0	40,0	40,0	40,0	40,0	40,0	40,0	40,0	40,0	40,0	40,0	40,0	40,0	40,0	40,0	40,0	38,2	34,8	31,6	28,5	25,5	22,8	20,1	17,9

Table G.2.1-7 — PN 63

PN	Group	$r_n$ (mm)	max. allowable temperature TS °C																								
			RT	100	150	200	250	300	350	400	450	460	470	480	490	500	510	520	530	540	550	560	570	580	590	600	
			max. allowable pressure PS bar																								
63	3E0	$\leq 50$	63,0	58,5	55,5	52,5	48,0	43,5	40,5	37,5	20,7																
	3E0	$50 < r_n \leq 150$	63,0	54,0	52,5	48,9	44,7	40,5	38,1	36,0	20,7																
	3E1	$\leq 50$	63,0	63,0	63,0	63,0	61,5	55,5	51,0	46,5	25,5																
	3E1	$50 < r_n \leq 150$	63,0	63,0	60,0	57,3	52,5	48,3	44,7	40,5	25,5																
	4E0	$\leq 80$	63,0	63,0	63,0	63,0	61,5	54,0	51,0	47,1	43,5	40,3	37,2	34,1	31,0	27,9	22,2	17,7	14,1								
	4E0	$80 < r_n \leq 90$	63,0	63,0	63,0	63,0	58,5	51,0	48,0	43,8	40,5	37,9	35,4	32,9	30,4	27,9	22,2	17,7	14,1								
	4E0	$90 < r_n \leq 150$	63,0	63,0	63,0	58,5	54,0	48,0	44,1	38,9	37,2	35,3	33,4	31,6	29,7	27,9	22,2	17,7	14,1								
	5E0	$\leq 80$	63,0	63,0	63,0	63,0	63,0	63,0	60,0	56,7	53,1	50,5	47,9	45,4	42,8	41,1	34,8	28,2	23,4	18,3	14,7	12,0	9,9				
	5E0	$80 < r_n \leq 90$	63,0	63,0	63,0	63,0	63,0	61,5	56,7	52,8	49,5	47,5	45,5	43,5	41,5	41,1	34,8	28,2	23,4	18,3	14,7	12,0	9,9				
	5E0	$90 < r_n \leq 150$	63,0	63,0	63,0	63,0	63,0	57,9	53,4	50,1	46,5	45,1	43,7	42,3	40,9	41,1	34,8	28,2	23,4	18,3	14,7	12,0	9,9				
	6E0	$\leq 150$	63,0	63,0	63,0	63,0	63,0	63,0	61,5	58,5	55,5	52,5	49,5	46,5	43,5	40,5	35,4	30,9	27,0	23,4	20,4	17,4	15,3	13,2	11,4	10,2	
	6E1	$\leq 150$	63,0	63,0	63,0	63,0	63,0	63,0	63,0	63,0	63,0	63,0	63,0	63,0	63,0	63,0	63,0	63,0	63,0	63,0	63,0	63,0	63,0	63,0	63,0	63,0	
	8E2	$35 < r_n \leq 70$	63,0	63,0	63,0	58,1	54,3	47,1	41,1	35,4																	
	8E2	$70 < r_n \leq 100$	63,0	63,0	58,4	54,6	50,1	41,1	35,4	29,4																	
	8E2	$100 < r_n \leq 150$	63,0	61,5	55,8	50,1	44,1	35,4	29,4	23,4																	
	8E3	$50 < r_n \leq 100$	63,0	63,0	63,0	63,0	63,0	61,8	57,0	50,1																	
	8E3	$100 < r_n \leq 150$	63,0	63,0	63,0	63,0	63,0	58,8	53,1	44,1																	
	9E0	$\leq 150$	63,0	63,0	63,0	63,0	63,0	63,0	63,0	63,0	63,0	63,0	63,0	63,0	63,0	63,0	63,0	63,0	56,4	50,1	44,1	38,4	33,3	28,5	24,3	20,7	17,7
	9E1	$\leq 130$	63,0	63,0	63,0	63,0	63,0	63,0	63,0	63,0	63,0	63,0	63,0	63,0	63,0	63,0	63,0	63,0	63,0	60,3	54,9	49,8	45,0	40,2	36,0	31,8	28,2

Table G.2.1-8 — PN 100

PN	Group	$r_h$ (mm)	max. allowable temperature TS °C																							
			RT	100	150	200	250	300	350	400	450	460	470	480	490	500	510	520	530	540	550	560	570	580	590	600
			max. allowable pressure PS bar																							
100	3E0	$\leq 50$	100,0	92,8	88,0	83,3	78,1	69,0	64,2	59,5	32,8															
	3E0	$50 < r_h \leq 150$	100,0	85,7	83,3	77,6	70,9	64,2	60,4	57,1	32,8															
	3E1	$\leq 50$	100,0	100,0	100,0	100,0	97,6	88,0	80,9	73,8	40,4															
	3E1	$50 < r_h \leq 150$	100,0	100,0	95,2	90,9	83,3	76,6	70,9	64,2	40,4															
	4E0	$\leq 60$	100,0	100,0	100,0	100,0	97,6	85,7	80,9	74,7	68,0	64,0	59,1	54,2	49,2	44,2	35,2	28,0	22,3							
	4E0	$60 < r_h \leq 90$	100,0	100,0	100,0	100,0	92,8	80,9	76,1	69,5	64,2	60,2	56,2	52,2	48,2	44,2	35,2	28,0	22,3							
	4E0	$90 < r_h \leq 150$	100,0	100,0	100,0	92,8	85,7	76,1	70,0	63,3	58,0	56,0	53,1	50,2	47,2	44,2	35,2	28,0	22,3							
	5E0	$\leq 60$	100,0	100,0	100,0	100,0	100,0	100,0	95,2	90,0	84,2	80,2	76,1	72,0	68,0	65,2	55,2	44,7	37,1	29,0	23,3	19,0	15,7			
	5E0	$60 < r_h \leq 90$	100,0	100,0	100,0	100,0	100,0	97,6	90,0	83,8	78,5	75,4	72,2	69,1	66,0	65,2	55,2	44,7	37,1	29,0	23,3	19,0	15,7			
	5E0	$90 < r_h \leq 150$	100,0	100,0	100,0	100,0	100,0	91,9	84,7	79,5	73,8	71,6	69,4	67,2	65,0	65,2	55,2	44,7	37,1	29,0	23,3	19,0	15,7			
	6E0	$\leq 150$	100,0	100,0	100,0	100,0	100,0	100,0	97,6	92,8	88,0	83,3	78,5	73,8	69,0	64,2	56,1	49,0	42,8	37,1	32,3	27,6	24,2	20,9	18,0	16,1
	6E1	$\leq 150$	100,0	100,0	100,0	100,0	100,0	100,0	100,0	100,0	100,0	100,0	100,0	100,0	94,8	89,3	83,5	78,5	73,8	69,0	64,2	59,5	54,7	50,0	45,2	40,4
	8E2	$35 < r_h \leq 70$	100,0	100,0	100,0	93,8	85,1	74,7	65,2	56,1																
	8E2	$70 < r_h \leq 100$	100,0	100,0	94,2	86,6	79,5	65,2	56,1	46,6																
	8E2	$100 < r_h \leq 150$	100,0	97,6	88,5	79,5	70,0	56,1	46,6	37,1																
	8E3	$50 < r_h \leq 100$	100,0	100,0	100,0	100,0	100,0	98,0	90,4	79,5																
	8E3	$100 < r_h \leq 150$	100,0	100,0	100,0	100,0	100,0	93,3	84,2	70,0																
	9E0	$\leq 150$	100,0	100,0	100,0	100,0	100,0	100,0	100,0	100,0	100,0	100,0	100,0	100,0	100,0	100,0	100,0	89,5	79,5	70,0	60,9	52,8	45,2	38,5	32,8	28,0
	9E1	$\leq 130$	100,0	100,0	100,0	100,0	100,0	100,0	100,0	100,0	100,0	100,0	100,0	100,0	100,0	100,0	100,0	100,0	95,7	87,1	79,0	71,4	63,8	57,1	50,4	44,7

Table G.2.1-9— PN 160

PN	Group	$r_n$ (mm)	max. allowable temperature TS °C																							
			RT	100	150	200	250	300	350	400	450	460	470	480	490	500	510	520	530	540	550	560	570	580	590	600
			max. allowable pressure PS bar																							
160	3E0	$\leq 50$	160,0	148,5	140,9	133,3	121,9	110,4	102,8	95,2																
	3E0	$50 < r_n \leq 150$	160,0	137,1	133,3	124,1	113,5	102,8	96,7	91,4	82,5															
	3E1	$\leq 50$	160,0	160,0	160,0	160,0	156,1	140,9	129,5	118,0	64,7															
	3E1	$50 < r_n \leq 150$	160,0	160,0	152,3	145,5	133,3	122,6	113,5	102,8	64,7															
	4E0	$\leq 80$	160,0	160,0	160,0	160,0	156,1	137,1	129,5	119,6	110,4	102,5	94,6	86,7	78,8	70,8	56,3	44,9	35,8							
	4E0	$80 < r_n \leq 90$	160,0	160,0	160,0	160,0	148,5	129,5	121,9	111,2	102,8	96,4	90,0	83,6	77,2	70,8	56,3	44,9	35,8							
	4E0	$90 < r_n \leq 150$	160,0	160,0	160,0	148,5	137,1	121,9	112,0	101,3	94,4	88,7	85,0	80,3	75,6	70,8	56,3	44,9	35,8							
	5E0	$\leq 80$	160,0	160,0	160,0	160,0	160,0	160,0	152,3	144,0	134,8	128,3	121,8	115,3	108,8	104,3	88,3	71,6	58,4	46,4	37,3	30,4	25,1			
	5E0	$80 < r_n \leq 90$	160,0	160,0	160,0	160,0	160,0	156,1	144,0	134,0	125,7	120,6	115,6	110,6	105,6	104,3	88,3	71,6	58,4	46,4	37,3	30,4	25,1			
	5E0	$90 < r_n \leq 150$	160,0	160,0	160,0	160,0	160,0	147,0	135,6	127,2	118,0	114,6	111,0	107,5	104,0	104,3	88,3	71,6	58,4	46,4	37,3	30,4	25,1			
	6E0	$\leq 150$	160,0	160,0	160,0	160,0	160,0	160,0	156,1	148,5	140,9	133,3	125,7	118,0	110,4	102,8	89,9	78,4	68,5	59,4	51,8	44,1	38,8	33,5	28,9	25,9
	6E1	$\leq 150$	160,0	160,0	160,0	160,0	160,0	160,0	160,0	160,0	160,0	160,0	160,0	160,0	135,7	110,9	86,0	73,1	61,7	53,3	44,9	38,0	32,7	28,1		
	8E2	$35 < r_n \leq 70$	160,0	160,0	160,0	150,0	137,9	119,6	104,3	88,9																
	8E2	$70 < r_n \leq 100$	160,0	160,0	150,8	138,6	127,2	104,3	88,9	74,6																
	8E2	$100 < r_n \leq 150$	160,0	156,1	141,7	127,2	112,0	88,9	74,6	58,4																
	8E3	$50 < r_n \leq 100$	160,0	160,0	160,0	160,0	160,0	156,9	144,7	127,2																
	8E3	$100 < r_n \leq 150$	160,0	160,0	160,0	160,0	160,0	148,3	134,8	112,0																
	9E0	$\leq 150$	160,0	160,0	160,0	160,0	160,0	160,0	160,0	160,0	160,0	160,0	160,0	160,0	160,0	160,0	160,0	143,2	127,2	112,0	97,5	84,5	72,3	61,7	52,5	44,9
	9E1	$\leq 130$	160,0	160,0	160,0	160,0	160,0	160,0	160,0	160,0	160,0	160,0	160,0	160,0	160,0	160,0	160,0	160,0	153,1	139,4	126,4	114,2	102,0	91,4	80,7	71,6

Table G.2.1-10 — PN 250

PN	Group	$r_h$ (mm)	max. allowable temperature TS °C																								
			RT	100	150	200	250	300	350	400	450	460	470	480	490	500	510	520	530	540	550	560	570	580	590	600	
			max. allowable pressure PS bar																								
250	3E0	$\leq 50$	250,0	232,1	220,2	208,3	190,4	172,6	160,7	148,8	82,1																
	3E0	$50 < r_h \leq 150$	250,0	214,2	208,3	194,0	177,3	160,7	151,1	142,8	82,1																
	3E1	$\leq 50$	250,0	250,0	250,0	250,0	244,0	220,2	202,3	194,5	101,1																
	3E1	$50 < r_h \leq 150$	250,0	250,0	238,0	227,3	208,3	191,6	177,3	160,7	101,1																
	4E0	$\leq 60$	250,0	250,0	250,0	250,0	244,0	214,2	202,3	196,9	172,6	160,1	147,8	135,5	123,2	110,7	88,0	70,2	55,9								
	4E0	$60 < r_h \leq 90$	250,0	250,0	250,0	250,0	232,1	202,3	190,4	173,8	160,7	150,7	140,7	130,7	120,7	110,7	88,0	70,2	55,9								
	4E0	$90 < r_h \leq 150$	250,0	250,0	250,0	232,1	214,2	190,4	175,0	158,3	147,6	140,1	132,8	125,5	118,2	110,7	88,0	70,2	55,9								
	5E0	$\leq 60$	250,0	250,0	250,0	250,0	250,0	250,0	238,0	225,0	210,7	200,5	190,3	180,1	170,0	163,0	138,0	111,9	92,8	72,6	58,3	47,6	39,2				
	5E0	$60 < r_h \leq 90$	250,0	250,0	250,0	250,0	250,0	244,0	225,0	209,5	196,4	188,5	180,7	172,8	165,0	163,0	138,0	111,9	92,8	72,6	58,3	47,6	39,2				
	5E0	$90 < r_h \leq 150$	250,0	250,0	250,0	250,0	250,0	229,7	211,9	198,8	184,5	179,1	173,5	168,0	162,5	163,0	138,0	111,9	92,8	72,6	58,3	47,6	39,2				
	6E0	$\leq 150$	250,0	250,0	250,0	250,0	250,0	250,0	244,0	232,1	220,2	208,3	196,4	184,5	172,6	160,7	140,4	122,6	107,1	92,8	80,9	69,0	60,7	52,3	45,2	40,4	
	6E1	$\leq 150$	250,0	250,0	250,0	250,0	250,0	250,0	250,0	250,0	250,0	250,0	250,0	250,0	212,1	173,3	134,5	114,2	96,4	83,3	70,2	59,5	51,1	44,0			
	8E2	$35 < r_h \leq 70$	250,0	250,0	250,0	234,5	215,4	186,9	163,0	140,4																	
	8E2	$70 < r_h \leq 100$	250,0	250,0	235,7	216,6	198,8	163,0	140,4	116,6																	
	8E2	$100 < r_h \leq 150$	250,0	244,0	221,4	198,8	175,0	140,4	116,6	92,8																	
	8E3	$50 < r_h \leq 100$	250,0	250,0	250,0	250,0	250,0	245,2	226,1	198,8																	
	8E3	$100 < r_h \leq 150$	250,0	250,0	250,0	250,0	250,0	233,3	210,7	175,0																	
	9E0	$\leq 150$	250,0	250,0	250,0	250,0	250,0	250,0	250,0	250,0	250,0	250,0	250,0	250,0	250,0	250,0	250,0	223,8	198,8	175,0	152,3	132,1	113,0	96,4	82,1	70,2	
	9E1	$\leq 130$	250,0	250,0	250,0	250,0	250,0	250,0	250,0	250,0	250,0	250,0	250,0	250,0	250,0	250,0	250,0	250,0	239,2	217,8	197,6	178,5	158,5	142,8	126,1	111,9	





Table G.2.1-12 — PN 400

PN	Group	$r_h$ (mm)	max. allowable temperature TS °C																							
			RT	100	150	200	250	300	350	400	450	460	470	480	490	500	510	520	530	540	550	560	570	580	590	600
			max. allowable pressure PS bar																							
400	3E0	$\leq 50$	400,0	371,4	352,3	333,3	304,7	276,1	257,1	238,0	131,4															
	3E0	$50 < r_h \leq 150$	400,0	342,8	333,3	310,4	283,8	257,1	241,9	228,5	131,4															
	3E1	$\leq 50$	400,0	400,0	400,0	400,0	390,4	352,3	323,8	295,2	161,9															
	3E1	$50 < r_h \leq 150$	400,0	400,0	380,9	363,8	333,3	306,6	283,8	257,1	161,9															
	4E0	$\leq 60$	400,0	400,0	400,0	400,0	390,4	342,8	323,8	299,0	276,1	256,2	236,5	216,8	197,1	177,1	140,9	112,3	89,5							
	4E0	$60 < r_h \leq 90$	400,0	400,0	400,0	400,0	371,4	323,8	304,7	278,0	257,1	241,1	225,1	209,1	193,1	177,1	140,9	112,3	89,5							
	4E0	$90 < r_h \leq 150$	400,0	400,0	400,0	371,4	342,8	304,7	280,0	253,3	236,1	224,2	212,5	200,8	189,1	177,1	140,9	112,3	89,5							
	5E0	$\leq 60$	400,0	400,0	400,0	400,0	400,0	400,0	380,9	360,0	337,1	320,8	304,5	288,2	272,0	260,9	220,9	179,0	148,5	116,1	93,3	76,1	62,8			
	5E0	$60 < r_h \leq 90$	400,0	400,0	400,0	400,0	400,0	360,4	360,0	335,2	314,2	301,7	289,1	276,5	264,0	260,9	220,9	179,0	148,5	116,1	93,3	76,1	62,8			
	5E0	$90 < r_h \leq 150$	400,0	400,0	400,0	400,0	400,0	367,6	339,0	318,0	295,2	286,5	277,7	268,8	260,0	260,9	220,9	179,0	148,5	116,1	93,3	76,1	62,8			
	6E0	$\leq 150$	400,0	400,0	400,0	400,0	400,0	400,0	380,4	371,4	352,3	333,3	314,2	295,2	276,1	257,1	224,7	196,1	171,4	148,5	129,5	110,4	97,1	83,8	72,3	64,7
	6E1	$\leq 150$	400,0	400,0	400,0	400,0	400,0	400,0	400,0	400,0	400,0	400,0	400,0	338,4	277,3	215,2	182,8	154,2	133,3	112,3	95,2	81,9	70,4			
	8E2	$35 < r_h \leq 70$	400,0	400,0	400,0	375,2	344,7	299,0	260,9	224,7																
	8E2	$70 < r_h \leq 100$	400,0	400,0	377,1	346,6	318,0	260,9	224,7	186,6																
	8E2	$100 < r_h \leq 150$	400,0	390,4	354,2	318,0	280,0	224,7	186,6	148,5																
	8E3	$50 < r_h \leq 100$	400,0	400,0	400,0	400,0	400,0	382,3	361,9	318,0																
	8E3	$100 < r_h \leq 150$	400,0	400,0	400,0	400,0	400,0	373,3	337,1	280,0																
	9E0	$\leq 150$	400,0	400,0	400,0	400,0	400,0	400,0	400,0	400,0	400,0	400,0	400,0	400,0	400,0	400,0	400,0	358,0	318,0	280,0	243,8	211,4	180,9	154,2	131,4	112,3
	9E1	$\leq 130$	400,0	400,0	400,0	400,0	400,0	400,0	400,0	400,0	400,0	400,0	400,0	400,0	400,0	400,0	400,0	400,0	362,8	348,5	316,1	285,7	255,2	228,5	201,9	179,0

## G.3 Austenitic and austenitic-ferritic steels

### G.3.1 General

p/t-ratings are given in Tables G.4.1-1 to G.4.1-12 for austenitic and austenitic-ferritic steels. They are calculated by using the strength values of steel forgings (see Table G.3.1-1) and are verified for flat steel products of the same group (see Table 9) up to and incl. 600 °C. Thickness related strength values for all thicknesses up to and including 150 mm have been considered.

p/t-ratings are calculated by using the strength values of steel forgings and are verified for flat steel products of the same group.

100 000 h creep rupture strength values are considered for materials marked with 'X' in Table G.3.1-1.

Maximum allowable pressures at temperatures for which 100 000 h creep rupture strength values have been considered are indicated in italic letters in Tables G.4.1-1 to G.4.1-12.

For flanges made from steel castings (type 21; material selection see Table 9) the p/t-ratings shall be the same as for the corresponding steel forgings respectively flat steel products (see Table 9). The wall thicknesses need to be verified (see provisions made in F.2.5).

NOTE For nominal design stress values of steel castings it may be necessary to consider the provisions given in applicable component or equipment standards (e.g. EN 12516).

### G.3.2 List of materials

Table G.3.1-1 — Austenitic and austenitic-ferritic materials

Group	Material	Material No.	EN	$R_p, R_e$	Creep	$\gamma_w$ (mm)	A%
10E0	X2CrNi18-9	1.4307	10222-5	$R_{p1,0t}$	X	—	35
10E1	X2CrNi18-10	1.4311	10222-5	$R_{p1,0t}$	—	—	35
11E0	X5CrNi18-10	1.4301	10222-5	$R_{p1,0t}$	X	—	35
12E0	X8CrNiTi18-10	1.4541	10222-5	$R_{p1,0t}$	X	—	30
12E0	X8CrNiNb18-10	1.4550	10222-5	$R_{p1,0t}$	—	—	30
13E0	X2CrNiMo17-12-2	1.4404	10222-5	$R_{p1,0t}$	—	—	35
14E0	X5CrNiMo17-12-2	1.4401	10222-5	$R_{p1,0t}$	X	—	35
15E0	X8CrNiMoTi17-12-2	1.4571	10222-5	$R_{p1,0t}$	X	—	35
16E0	X2CrNiMoN22-5-3	1.4482	10222-5	$R_{p0,2t}$	—	—	25
11E0	X8CrNi18-10	1.4948	10222-5	$R_{p1,0t}$	X	—	35
12E0	X8CrNiTiB18-10	1.4941	10222-5	$R_{p1,0t}$	X	—	30

NOTE Table contains a selection of commonly used austenitic and austenitic-ferritic materials.

G.3.3 p/t-Ratings

Table G.4.1-1 — PN 2,5

PN	Group	Material-No.	max. allowable temperature TS °C															
			RT	100	150	200	250	300	350	400	450	500	550	560	570	580	590	600
			max. allowable pressure PS bar															
2,5	10E0	1.4307	2,5	2,1	1,9	1,7	1,6	1,5	1,4	1,3	1,3	1,2	1,0	1,0	0,9	0,8	0,7	0,7
	10E1	1.4311	2,5	2,5	2,5	2,2	2,0	1,9	1,9	1,8	1,8	1,7						
	11E0	1.4301	2,5	2,2	2,0	1,8	1,7	1,6	1,5	1,4	1,4	1,4	1,0	1,0	0,9	0,8	0,7	0,7
	12E0	1.4541	2,5	2,4	2,3	2,2	2,1	1,9	1,9	1,8	1,8	1,7	1,6	1,5	1,4	1,2	1,1	1,0
	12E0	1.4550	2,5	2,5	2,3	2,2	2,1	1,9	1,9	1,8	1,8	1,7						
	13E0	1.4404	2,5	2,3	2,1	1,9	1,8	1,7	1,6	1,6	1,5	1,5						
	14E0	1.4401	2,5	2,5	2,2	2,1	1,9	1,8	1,7	1,7	1,6	1,6	1,6	1,6	1,5	1,5	1,5	1,4
	15E0	1.4571	2,5	2,5	2,4	2,3	2,2	2,0	2,0	1,9	1,9	1,8	1,8	1,8	1,8	1,6	1,5	1,3
	16E0	1.4462	2,5	2,5	2,5	2,5	2,5											
	11E0	1.4948	2,5	2,2	2	1,8	1,7	1,6	1,5	1,5	1,4	1,4	1,3	1,3	1,2	1,2	1,1	1
	12E0	1.4941	2,5	2,3	2,2	2,1	2,0	2,0	1,9	1,9	1,8	1,8	1,7	1,7	1,6	1,5	1,3	1,2

EN 1092-1:2007 (E)

Table G.4.1-2 — PN 6

PN	Group	Material-No.	max. allowable temperature TS °C															
			RT	100	150	200	250	300	350	400	450	500	550	560	570	580	590	600
			max. allowable pressure PS bar															
6	10E0	1.4307	6,0	5,1	4,6	4,2	3,9	3,6	3,4	3,3	3,2	3,1	2,6	2,4	2,2	2,0	1,8	1,6
	10E1	1.4311	6,0	6,0	6,0	5,3	5,0	4,7	4,6	4,4	4,3	4,2						
	11E0	1.4301	6,0	5,4	4,9	4,4	4,1	3,8	3,6	3,5	3,5	3,4	2,6	2,4	2,2	2,0	1,8	1,6
	12E0	1.4541	6,0	5,9	5,6	5,3	5,0	4,7	4,6	4,4	4,3	4,2	4,0	3,6	3,3	3,0	2,7	2,4
	12E0	1.4550	6,0	6,0	5,6	5,3	5,0	4,7	4,6	4,4	4,3	4,2						
	13E0	1.4404	6,0	5,6	5,1	4,7	4,4	4,1	3,9	3,8	3,7	3,6						
	14E0	1.4401	6,0	6,0	5,4	5,0	4,7	4,4	4,2	4,1	4,0	3,9	3,9	3,8	3,8	3,7	3,7	3,3
	15E0	1.4571	6,0	6,0	5,8	5,6	5,3	5,0	4,8	4,6	4,6	4,5	4,4	4,4	4,4	4,0	3,6	3,3
	16E0	1.4462	6,0	6,0	6,0	6,0	6,0											
	11E0	1.4948	6,0	5,4	4,9	4,4	4,2	3,9	3,7	3,6	3,5	3,3	3,2	3,1	3,1	3,0	2,8	2,5
	12E0	1.4941	6,0	5,7	5,4	5,1	5,0	4,9	4,7	4,6	4,4	4,3	4,2	4,0	4,0	3,6	3,2	2,9

Table G.4.1-3 — PN 10

PN	Group	Material-No.	max. allowable temperature TS °C															
			RT	100	150	200	250	300	350	400	450	500	550	560	570	580	590	600
			max. allowable pressure PS bar															
10	10E0	1.4307	10,0	8,6	7,7	7,0	6,5	6,0	5,7	5,5	5,3	5,1	4,3	4,0	3,7	3,4	3,0	2,8
	10E1	1.4311	10,0	10,0	10	8,9	8,3	7,9	7,6	7,4	7,2	7						
	11E0	1.4301	10,0	9,0	8,1	7,4	6,9	6,4	6,1	5,9	5,8	5,7	4,3	4,0	3,7	3,4	3,0	2,8
	12E0	1.4541	10,0	9,9	9,3	8,8	8,4	7,9	7,6	7,4	7,2	7	6,7	6,1	5,6	5,0	4,5	4,0
	12E0	1.4550	10,0	10,0	9,3	8,8	8,4	7,9	7,6	7,4	7,2	7						
	13E0	1.4404	10,0	9,4	8,6	7,9	7,4	6,9	6,6	6,4	6,2	6						
	14E0	1.4401	10,0	10,0	9,0	8,4	7,9	7,4	7,1	6,8	6,7	6,6	6,5	6,4	6,3	6,2	6,1	5,6
	15E0	1.4571	10,0	10,0	9,8	9,3	8,8	8,3	8,0	7,8	7,6	7,5	7,4	7,4	7,3	6,7	6,0	5,5
	16E0	1.4462	10,0	10,0	10,0	10,0	10,0											
	11E0	1.4948	10,0	9,0	8,1	7,4	7,0	6,5	6,2	6,0	5,8	5,6	5,3	5,2	5,1	5,0	4,6	4,2
	12E0	1.4941	10,0	9,5	9,0	8,6	8,3	8,1	7,9	7,7	7,4	7,2	7,0	6,8	6,6	6,0	5,4	4,8

Table G.4.1-4 – PN 16

PN	Group	Material-No.	max. allowable temperature TS °C															
			RT	100	150	200	250	300	350	400	450	500	550	560	570	580	590	600
			max. allowable pressure PS bar															
16	10E0	1.4307	16,0	13,7	12,3	11,2	10,4	9,6	9,2	8,8	8,5	8,3	7,0	6,4	5,9	5,4	4,9	4,4
	10E1	1.4311	16,0	16	16	14,2	13,3	12,7	12,2	11,8	11,6	11,3						
	11E0	1.4301	16,0	14,5	13,1	11,9	11	10,2	9,8	9,5	9,3	9,1	7,0	6,4	5,9	5,4	4,9	4,4
	12E0	1.4541	16,0	15,8	14,9	14,1	13,4	12,7	12,2	11,8	11,6	11,3	10,8	9,8	8,9	8,1	7,3	6,5
	12E0	1.4550	16,0	16,0	14,9	14,1	13,4	12,7	12,2	11,8	11,6	11,3						
	13E0	1.4404	16,0	15,1	13,7	12,7	11,9	11	10,5	10,2	10	9,7						
	14E0	1.4401	16,0	16,0	14,5	13,4	12,7	11,8	11,4	10,9	10,7	10,5	10,4	10,3	10,1	10,0	9,9	8,9
	15E0	1.4571	16,0	16,0	15,6	14,9	14,1	13,3	12,8	12,4	12,2	12	11,9	11,8	11,7	10,7	9,7	8,8
	16E0	1.4462	16,0	16,0	16,0	16,0	16,0											
	11E0	1.4948	16,0	14,5	13,1	11,9	11,2	10,4	10,0	9,6	9,3	8,9	8,6	8,4	8,2	8,1	7,4	6,7
	12E0	1.4941	16,0	15,3	14,5	13,7	13,4	13,1	12,7	12,3	11,9	11,5	11,2	10,8	10,6	9,6	8,6	7,7

Table G.4.1-5 – PN 25

PN	Group	Material-No.	max. allowable temperature TS °C															
			RT	100	150	200	250	300	350	400	450	500	550	560	570	580	590	600
			max. allowable pressure PS bar															
25	10E0	1.4307	25,0	21,5	19,2	17,5	16,3	15,1	14,4	13,8	13,3	12,9	10,9	10,1	9,2	8,5	7,7	7,0
	10E1	1.4311	25,0	25,0	25,0	22,2	20,8	19,8	19,1	18,5	18,1	17,7						
	11E0	1.4301	25,0	22,7	20,4	18,6	17,2	16,0	15,3	14,8	14,5	14,2	10,9	10,1	9,2	8,5	7,7	7,0
	12E0	1.4541	25,0	24,7	23,3	22,1	21,0	19,8	19,1	18,5	18,1	17,7	16,9	15,3	14,0	12,7	11,4	10,2
	12E0	1.4550	25,0	25,0	23,3	22,1	21,0	19,8	19,1	18,5	18,1	17,7						
	13E0	1.4404	25,0	23,6	21,5	19,8	18,6	17,2	16,5	16,0	15,6	15,2						
	14E0	1.4401	25,0	25,0	22,7	21,0	19,8	18,5	17,8	17,1	16,8	16,5	16,3	16,0	15,8	15,6	15,4	14,0
	15E0	1.4571	25,0	25,0	24,5	23,3	22,1	20,8	20,1	19,5	19,1	18,8	18,6	18,5	18,3	16,7	15,2	13,8
	16E0	1.4462	25,0	25,0	25,0	25,0	25,0											
	11E0	1.4948	25,0	22,7	20,4	18,6	17,5	16,3	15,7	15,1	14,5	14,0	13,4	13,1	12,9	12,7	11,6	10,5
	12E0	1.4941	25,0	23,9	22,7	21,5	20,9	20,4	19,8	19,2	18,6	18,0	17,5	17,0	16,6	15,1	13,5	12,1

EN 1092-1:2007 (E)

Table G.4.1-6 — PN 40

PN	Group	Material-No.	max. allowable temperature TS °C															
			RT	100	150	200	250	300	350	400	450	500	550	560	570	580	590	600
			max. allowable pressure PS bar															
40	10E0	1.4307	40,0	34,4	30,8	28,0	26,0	24,1	23,0	22,0	21,4	20,7	17,5	16,1	14,8	13,7	12,3	11,2
	10E1	1.4311	40,0	40,0	40,0	35,6	33,3	31,8	30,6	29,7	29,0	28,3						
	11E0	1.4301	40,0	36,3	32,7	29,9	27,6	25,7	24,5	23,8	23,3	22,8	17,5	16,1	14,8	13,7	12,3	11,2
	12E0	1.4541	40,0	39,6	37,3	35,4	33,7	31,8	30,6	29,7	29,0	28,3	27,0	24,5	22,4	20,3	18,2	16,3
	12E0	1.4550	40,0	40,0	37,3	35,4	33,7	31,8	30,6	29,7	29,0	28,3						
	13E0	1.4404	40,0	37,9	34,4	31,8	29,9	27,6	26,4	25,7	25,0	24,3						
	14E0	1.4401	40,0	40,0	36,3	33,7	31,8	29,7	28,5	27,4	26,9	26,4	26,0	25,7	25,4	25,0	24,7	22,4
	15E0	1.4571	40,0	40,0	39,2	37,3	35,4	33,3	32,1	31,2	30,6	30,0	29,9	29,6	29,3	26,8	24,3	22,0
	16E0	1.4462	40,0	40,0	40,0	40,0	40,0											
	11E0	1.4948	40,0	36,3	32,7	29,9	28,0	26,0	25,1	24,1	23,3	22,4	21,5	21,0	20,7	20,3	18,6	16,9
	12E0	1.4941	40,0	38,2	36,3	34,4	33,5	32,7	31,8	30,8	29,9	28,9	28,0	27,2	26,6	24,1	21,7	19,4

Table G.4.1-7 — PN 63

PN	Group	Material-No.	max. allowable temperature TS °C															
			RT	100	150	200	250	300	350	400	450	500	550	560	570	580	590	600
			max. allowable pressure PS bar															
63	10E0	1.4307	63,0	54,3	48,6	44,1	41,1	38,1	36,3	34,8	33,7	32,7	27,6	25,5	23,4	21,6	19,5	17,7
	10E1	1.4311	63,0	63,0	63,0	56,1	52,5	50,1	48,3	46,8	45,7	44,7						
	11E0	1.4301	63,0	57,3	51,6	47,1	43,5	40,5	38,7	37,5	36,7	36,0	27,6	25,5	23,4	21,6	19,5	17,7
	12E0	1.4541	63,0	62,4	58,8	55,8	53,1	50,1	48,3	46,8	45,7	44,7	42,6	38,7	35,4	32,1	28,8	25,8
	12E0	1.4550	63,0	63,0	58,8	55,8	53,1	50,1	48,3	46,8	45,7	44,7						
	13E0	1.4404	63,0	59,7	54,3	50,1	47,1	43,5	41,7	40,5	39,4	38,4						
	14E0	1.4401	63,0	63,0	57,3	53,1	50,1	46,8	45,0	43,2	42,4	41,7	41,1	40,5	40,0	39,5	39,0	35,4
	15E0	1.4571	63,0	63,0	61,8	58,8	55,8	52,5	50,7	49,2	48,3	47,4	47,1	46,6	46,2	42,3	38,4	34,8
	16E0	1.4462	63,0	63,0	63,0	63,0	63,0											
	11E0	1.4948	63,0	57,3	51,6	47,1	44,1	41,1	39,6	38,1	36,7	35,4	33,9	33,0	32,6	32,1	29,4	26,7
	12E0	1.4941	63,0	60,3	57,3	54,3	52,8	51,6	50,1	48,6	47,1	45,6	44,1	42,8	42,0	38,1	34,2	30,6

Table G.4.1-8 — PN 100

PN	Group	Material-No.	max. allowable temperature TS °C															
			RT	100	150	200	250	300	350	400	450	500	550	560	570	580	590	600
			max. allowable pressure PS bar															
100	10E0	1.4307	100,0	86,1	77,1	70,0	65,2	60,4	57,6	55,2	53,5	51,9	43,8	40,4	37,1	34,2	30,9	28,0
	10E1	1.4311	100,0	100,0	100,0	89,0	83,3	79,5	76,6	74,2	72,6	70,9						
	11E0	1.4301	100,0	90,9	81,9	74,7	69,0	64,2	61,4	59,5	58,3	57,1	43,8	40,4	37,1	34,2	30,9	28,0
	12E0	1.4541	100,0	99,0	93,3	88,5	84,2	79,5	76,6	74,2	72,6	70,9	67,6	61,4	56,1	50,9	45,7	40,9
	12E0	1.4550	100,0	100,0	93,3	88,5	84,2	79,5	76,6	74,2	72,6	70,9						
	13E0	1.4404	100,0	94,7	86,1	79,5	74,7	69,0	66,1	64,2	62,6	60,9						
	14E0	1.4401	100,0	100,0	90,9	84,2	79,5	74,2	71,4	68,5	67,3	66,1	65,2	64,3	63,5	62,7	61,9	56,1
	15E0	1.4571	100,0	100,0	98,0	93,3	88,5	83,3	80,4	78,0	76,6	75,2	74,7	74,0	73,3	67,1	60,9	55,2
	16E0	1.4462	100,0	100,0	100,0	100,0	100,0											
	11E0	1.4948	100,0	90,9	81,9	74,7	70,0	65,2	62,8	60,4	58,3	56,1	53,8	52,5	51,7	50,9	46,6	42,3
	12E0	1.4941	100,0	95,7	90,9	86,1	83,8	81,9	79,5	77,1	74,7	72,3	70,0	68,0	66,6	60,4	54,2	48,5

Table G.4.1-9 — PN 160

PN	Group	Material-No.	max. allowable temperature TS °C															
			RT	100	150	200	250	300	350	400	450	500	550	560	570	580	590	600
			max. allowable pressure PS bar															
160	10E0	1.4307	160,0	137,9	123,4	112,0	104,3	96,7	92,1	88,3	85,7	83,0	70,0	64,7	59,4	54,8	49,5	44,9
	10E1	1.4311	160,0	160,0	160,0	142,4	133,3	127,2	122,6	118,8	116,1	113,5						
	11E0	1.4301	160,0	145,5	131,0	119,6	110,4	102,8	98,2	95,2	93,3	91,4	70,0	64,7	59,4	54,8	49,5	44,9
	12E0	1.4541	160,0	158,4	149,3	141,7	134,8	127,2	122,6	118,8	116,1	113,5	108,1	98,2	89,9	81,5	73,1	65,5
	12E0	1.4550	160,0	160,0	149,3	141,7	134,8	127,2	122,6	118,8	116,1	113,5						
	13E0	1.4404	160,0	151,6	137,9	127,2	119,6	110,4	105,9	102,8	100,1	97,5						
	14E0	1.4401	160,0	160,0	145,5	134,8	127,2	118,8	114,2	109,7	107,8	105,9	104,3	103,0	101,6	100,3	99,0	89,9
	15E0	1.4571	160,0	160,0	156,9	149,3	141,7	133,3	128,7	124,9	122,6	120,3	119,6	118,5	117,3	107,4	97,5	88,3
	16E0	1.4462	160,0	160,0	160,0	160,0	160,0											
	11E0	1.4948	160,0	145,5	131,0	119,6	112,0	104,3	100,5	96,7	93,3	89,9	86,0	84,0	82,8	81,5	74,6	67,8
	12E0	1.4941	160,0	153,1	145,5	137,9	134,0	131,0	127,2	123,4	119,6	115,8	112,0	108,9	106,6	96,7	86,8	77,7

EN 1092-1:2007 (E)

Table G.4.1-10 — PN 250

PN	Group	Material- No.	max. allowable temperature TS °C															
			RT	100	150	200	250	300	350	400	450	500	550	560	570	580	590	600
			max. allowable pressure PS bar															
250	10E0	1.4307	250,0	215,4	192,8	175,0	163,0	151,1	144,0	138,0	133,9	129,7	109,5	101,1	92,8	85,7	77,3	70,2
	10E1	1.4311	250,0	250,0	250,0	222,6	208,3	198,8	191,6	185,7	181,5	177,3						
	11E0	1.4301	250,0	227,3	204,7	186,9	172,6	160,7	153,5	148,8	145,8	142,8	109,5	101,1	92,8	85,7	77,3	70,2
	12E0	1.4541	250,0	247,6	233,3	221,4	210,7	198,8	191,6	185,7	181,5	177,3	169,0	153,5	140,4	127,3	114,2	102,3
	12E0	1.4550	250,0	250,0	233,3	221,4	210,7	198,8	191,6	185,7	181,5	177,3						
	13E0	1.4404	250,0	236,9	215,4	198,8	186,9	172,6	165,4	160,7	156,5	152,3						
	14E0	1.4401	250,0	250,0	227,3	210,7	198,8	185,7	178,5	171,4	168,4	165,4	163,0	160,9	158,8	156,7	154,7	140,4
	15E0	1.4571	250,0	250,0	245,2	233,3	221,4	208,3	201,1	195,2	191,6	188,0	186,9	185,1	183,3	167,8	152,3	138,0
	16E0	1.4462	250,0	250,0	250,0	250,0	250,0											
	11E0	1.4948	250,0	227,3	204,7	186,9	175,0	163,0	157,1	151,1	145,8	140,4	134,5	131,2	129,4	127,3	116,6	105,9
	12E0	1.4941	250,0	239,2	227,3	215,4	209,5	204,7	198,8	192,8	186,9	180,9	175,0	170,1	166,6	151,1	135,7	121,4

Table G.4.1-11 — PN 320

PN	Group	Material- No.	max. allowable temperature TS °C															
			RT	100	150	200	250	300	350	400	450	500	550	560	570	580	590	600
			max. allowable pressure PS bar															
320	10E0	1.4307	320,0	275,8	246,8	224,0	208,7	193,5	184,3	176,7	171,4	166,0	140,1	129,5	118,8	109,7	99,0	89,9
	10E1	1.4311	320,0	320,0	320,0	284,9	266,6	254,4	245,3	237,7	232,3	227,0						
	11E0	1.4301	320,0	291,0	262,0	239,2	220,9	205,7	196,5	190,4	186,6	182,8	140,1	129,5	118,8	109,7	99,0	89,9
	12E0	1.4541	320,0	316,9	298,6	283,4	269,7	254,4	245,3	237,7	232,3	227,0	216,3	196,5	179,8	163,0	146,2	131,0
	12E0	1.4550	320,0	320,0	298,6	283,4	269,7	254,4	245,3	237,7	232,3	227,0						
	13E0	1.4404	320,0	303,2	275,8	254,4	239,2	220,9	211,8	205,7	200,3	195,0						
	14E0	1.4401	320,0	320,0	291,0	269,7	254,4	237,7	228,5	219,4	215,6	211,8	208,7	206,0	203,3	200,6	198,0	179,8
	15E0	1.4571	320,0	320,0	313,9	298,6	283,4	266,6	257,5	249,9	245,3	240,7	239,2	237,0	234,6	214,8	195,0	176,7
	16E0	1.4462	320,0	320,0	320,0	320,0	320,0											
	11E0	1.4948	320,0	291,0	262,0	239,2	224,0	208,7	201,1	193,5	186,6	179,8	172,1	168,0	165,7	163,0	149,3	135,6
	12E0	1.4941	320,0	306,2	291,0	275,8	268,1	262,0	254,4	246,8	239,2	231,6	224,0	217,8	213,3	193,5	173,7	155,4



Table G.A.1-12 — PN 400

PN	Group	Material- No.	max. allowable temperature TS °C															
			RT	100	150	200	250	300	350	400	450	500	550	560	570	580	590	600
			max. allowable pressure PS bar															
400	10E0	1.4307	400,0	344,7	308,5	280,0	260,9	241,9	230,4	220,9	214,2	207,6	175,2	161,9	148,5	137,1	123,8	112,3
	10E1	1.4311	400,0	400,0	400,0	356,1	333,3	318,0	306,6	297,1	290,4	283,8						
	11E0	1.4301	400,0	363,8	327,6	299,0	276,1	257,1	245,7	238,0	233,3	228,5	175,2	161,9	148,5	137,1	123,8	112,3
	12E0	1.4541	400,0	396,1	373,3	354,2	337,1	318,0	306,6	297,1	290,4	283,8	270,4	245,7	224,7	203,8	182,8	163,8
	12E0	1.4550	400,0	400,0	373,3	354,2	337,1	318,0	306,6	297,1	290,4	283,8						
	13E0	1.4404	400,0	379,0	344,7	318,0	299,0	276,1	264,7	257,1	250,4	243,8						
	14E0	1.4401	400,0	400,0	363,8	337,1	318,0	297,1	285,7	274,2	269,5	264,7	260,9	257,5	254,1	250,8	247,6	224,7
	15E0	1.4571	400,0	400,0	392,3	373,3	354,2	333,3	321,9	312,3	306,6	300,9	299,0	296,2	293,3	268,5	243,8	220,9
	16E0	1.4462	400,0	400,0	400,0	400,0	400,0											
	11E0	1.4948	400,0	363,8	327,6	299,0	280,0	260,9	251,4	241,9	233,3	224,7	215,2	210,0	207,1	203,8	186,6	169,5
	12E0	1.4941	400,0	382,8	363,8	344,7	335,2	327,6	318,0	308,5	299,0	289,5	280,0	272,2	266,6	241,9	217,1	194,2

## Annex H (informative)

### Rings for tongue and groove flanges

The rings should be manufactured from the same material as the flanges they are used with unless otherwise agreed between flange manufacturer and pressure equipment manufacturer.

$R_z = 160 \mu\text{m}$

$R_a = 40 \mu\text{m}$  turned

Table H.1 — Rings for PN 10 to PN 100

Dimensions in millimetres

DN	Inner diameter	Outer diameter	Thickness
	+0,5 0	0 -0,5	+1 0
10	24	34	10
15	29	39	
20	36	50	
25	43	57	
32	51	65	
40	61	75	
50	73	87	
65	95	109	
80	106	120	12
100	129	149	
125	155	175	
150	183	203	
200	239	259	
250	292	312	
300	343	363	14
350	395	421	
400	447	473	
500	549	575	
600	649	675	
700	751	777	
800	856	882	
900	961	987	
1 000	1 062	1 092	16

## Annex I (informative)

### Flanges with fixed inner diameter

#### I.1 General

The Metric pipe standard has a fixed inside diameter (ID), which differs from the EN, DIN and ISO pipe standard that has a fixed outside diameter (OD). Mating dimensions of flanges and collars of the Metric system comply with the other mating dimensions of this standard.

#### I.2 Scope

Annex I describes flanges and collars which are commonly used in the metric system and Tables I.1 and I.2 specify dimensions which differ from, or are missing, in Tables 12 to 15.

Table I.1 — Dimensions for types 01M, 02M, 11M

Dimensions in millimetres

Nominal	Flange type					
	01M	02M		11M		
ID	Q	PN 10	PN 16	PN 25	PN 40	
		B <sub>2</sub>	B <sub>2</sub>	B <sub>2</sub>	B <sub>2</sub>	
10	0,8	16	16	16	16	All dimensions are corresponding to the Tables in this standard, except A, which is determined by the ID and the OD of the pipe. This information shall be specified by the pressure equipment manufacturer. If no A-measure is specified it is determined by the nominal ID + S x 2. Allowable external pipe force is 70% of the force in Annex E for Type 11 flange
15	0,7	22	22	22	22	
20	0,6	30	30	30	30	
25	0,8	36	36	36	36	
32	1,1	46	46	46	46	
40	1,2	52	52	52	52	
50	1,2	64	64	64	64	
65	1,4	81	81	81	81	
80	1,6	94	94	94	94	
100	1,7	113	113	118	118	
125	1,8	140	140	140	140	
150	2,2	165	165	168	168	
200	2,4	219	219	222	225	
250	3,5	273	273	279	279	
300	3,6	324	324	329	336	
350	3,9	374	376	380	386	
400	4,6	426	428	432	445	
450	5,0	475	480	485	496	
500	5,5	525	530	540	546	
600	6,5	628	634	645	650	
700	-	732	736	745	-	
800	-	834	840	852	-	
900	-	938	946	958	-	
1000	-	1046	1046	-	-	
1200	-	1246	1254	-	-	

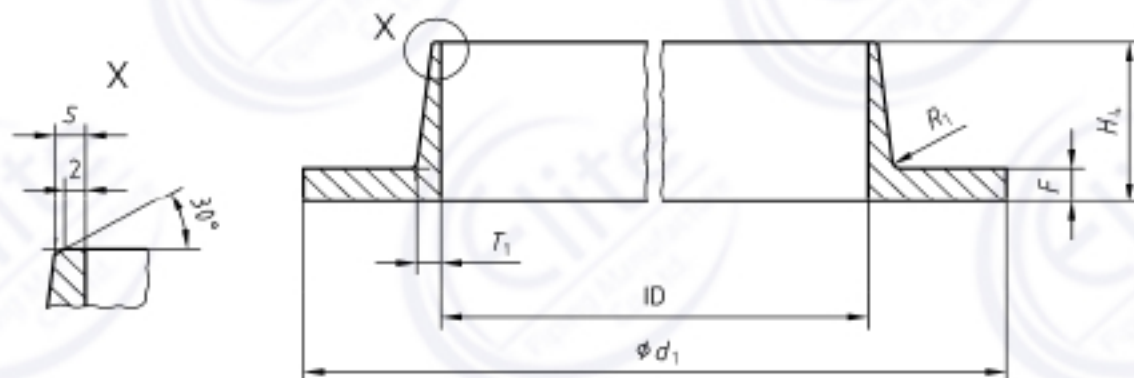

R1 to be decided by the flange manufacturer  
Designation: Type 35M

Figure I.1 — Type 35M (weld on collar with conical hub)

Table I.2 — Dimensions for type 35M (weld on collar with conical hub)

ID	PN 10					PN 16					PN 25					PN 40					
	$d_1$	$H_a$	$F$	$S$	$T_1$	$d_1$	$H_a$	$F$	$S$	$T_1$	$d_1$	$H_a$	$F$	$S$	$T_1$	$d_1$	$H_a$	$F$	$S$	$T_1$	
10	—	—	—	—	—	—	—	—	—	—	—	—	—	—	—	—	—	—	—	—	—
20	—	—	—	—	—	58	40	6	2,0	2,0	—	—	—	—	—	58	40	6	2,5	3,0	—
25	—	—	—	—	—	68	40	6	2,0	2,0	—	—	—	—	—	68	40	6	2,5	3,0	—
32	—	—	—	—	—	78	40	6	2,0	2,0	—	—	—	—	—	78	40	6	2,5	3,5	—
40	—	—	—	—	—	88	45	6	2,0	2,0	—	—	—	—	—	88	45	8	2,5	3,5	—
50	—	—	—	—	—	102	45	8	2,0	2,0	—	—	—	—	—	102	45	8	2,5	4,0	—
65	—	—	—	—	—	122	45	8	2,5	2,5	—	—	—	—	—	122	45	10	2,5	4,5	—
80	—	—	—	—	—	138	50	10	3,0	3,0	—	—	—	—	—	138	55	10	2,5	4,5	—
100	—	—	—	—	—	158	50	10	3,0	4,0	—	—	—	—	—	162	55	10	3,0	5,0	—
125	—	—	—	—	—	188	50	10	3,0	5,0	—	—	—	—	—	188	55	12	3,5	6,0	—
150	—	—	—	—	—	212	50	10	3,0	5,0	—	—	—	—	—	218	65	12	4,0	7,0	—
200	—	—	—	—	—	268	65	10	3,0	7,0	278	65	12,0	5,0	9,0	285	85	20	6,0	10,0	—
250	—	—	—	—	—	320	70	12	3,5	10,0	335	75	15,0	6,5	10,0	345	100	22	8,0	12,0	—
300	370	60	12	3,0	8,0	370	70	12	4,0	10,0	390	80	16,0	7,5	11,5	410	110	24	9,0	15,0	—
350	430	60	12	3,5	8,0	430	70	15	4,5	10,0	450	85	18,0	5,0	12,0	465	120	30	10,0	15,0	—
400	482	65	12	3,5	8,0	482	80	15	5,0	12,0	505	95	18,0	6,0	13,5	535	130	30	12,0	20,0	—
450	532	70	15	3,5	8,0	532	85	15	5,0	12,0	555	105	20,0	8,0	15,0	560	135	30	12,0	20,0	—
500	585	75	15	4,0	9,0	585	95	18	5,0	12,0	615	115	22,0	8,0	15,0	615	140	35	15,0	20,0	—
600	685	80	15	4,0	10,0	685	100	18	6,0	14,0	720	115	24,0	12,0	18,0	735	150	40	15,0	24,0	—
700	800	90	15	4,5	12,0	795	110	20	10,0	14,0	820	115	30,0	15,0	20,0	—	—	—	—	—	—
800	905	100	15	5,0	13,0	900	110	22	12,0	16,0	930	115	34,0	15,0	22,0	—	—	—	—	—	—
900	1 005	110	18	6,0	15,0	1000	115	24	12,0	18,0	1 030	130	40,0	18,0	24,0	—	—	—	—	—	—
1 000	1 110	120	18	8,0	18,0	1115	130	32	15,0	18,0	—	—	—	—	—	—	—	—	—	—	—
1 200	1 330	130	22	10,0	18,0	1330	130	32	15,0	22,0	—	—	—	—	—	—	—	—	—	—	—

Table I.3 — Dimensions for types 36M and 37M

DN	PN 10								PN 16								Chamfer
	Type 36M				Type 37M				Type 36M				Type 37M				
	Sp	S	F	H <sub>4</sub>	Sp	S	F	H <sub>4</sub>	Sp	S	F	H <sub>4</sub>	Sp	S	F	H <sub>4</sub>	
10	2,00	2,00	2,00	35,00	2,00	2,00	2,00	8	2,00	2,00	2,00	35,00	2,00	2,00	2,50	8	A *
15	2,00	2,00	2,00	38,00	2,00	2,00	2,00	9	2,00	2,00	2,00	38,00	2,00	2,00	2,50	9	
20	2,60	2,60	2,50	40,00	2,00	2,00	2,00	10	2,60	2,60	2,50	40,00	2,00	2,00	3,00	10	
25	2,60	2,60	2,50	40,00	2,00	2,00	2,00	12	2,60	2,60	2,50	40,00	2,00	2,00	3,00	12	
32	3,20	3,20	3,00	42,00	2,00	2,00	2,00	14	3,20	3,20	3,00	42,00	2,00	2,00	3,00	14	
40	3,20	3,20	3,00	45,00	2,00	2,00	2,00	17	3,20	3,20	3,00	45,00	2,00	2,00	3,00	17	
50	3,20	3,20	3,00	45,00	2,00	2,00	2,00	18	3,20	3,20	3,00	45,00	2,00	2,00	4,00	18	
65	3,20	3,20	3,00	45,00	2,00	2,00	3,00	20	3,20	3,20	3,00	45,00	2,00	2,00	4,00	20	
80	3,20	3,20	3,00	50,00	2,00	2,00	3,00	24	3,20	3,20	3,00	50,00	3,20	3,20	4,00	24	
100	3,20	3,20	4,00	52,00	3,20	3,20	4,00	27									
125	3,20	4,00	4,00	55,00	3,20	4,00	5,00	27									
150	3,20	5,00	5,00	55,00	3,20	4,50	5,00	27									
200	3,20	6,00	6,00	62,00	3,20	5,00	6,00	26									
250	3,20	8,00	8,00	68,00													
300	3,20	8,00	8,00	68,00													
350	3,20	8,00	8,00	68,00													
400	3,20	8,00	8,00	72,00													

NOTE Metric types, inside diameter same as DN, missing dimensions as for ISO Types 36 and 37. Loose flanges from Table I.1.

a Chamfer A and B as for Types 36 and 37, bevel outside of collar neck.

## Annex J (informative)

### Mating dimensions for flanges with higher DN

**Table J-1 — Dimensions of PN 25 flanges,  
symbols see Figure 9**

Dimensions in millimetres

DN	Mating dimensions <sup>a</sup>					Outside diameter of neck <i>A</i>
	Outside diameter <i>D</i>	Diameter of bolt circle <i>K</i>	Diameter of bolt hole <i>L</i>	Bolting		
				Number	Size	
Flange type						
01, 02, 04, 05, 11, 12, 13, 21						11 21 <sup>b</sup> 35 - 37
1 200	1 530	1 420	56	32	M52	1 219,0
1 400	1 755	1 640	62	36	M56	1 422,0
1 600	1 975	1 860	62	40	M56	1 626,0
1 800	2 195	2 070	70	44	M64	1 829,0
2 000	2 425	2 300	70	48	M64	2 032,0

<sup>a</sup> Further dimensions to be specified by the purchaser.

<sup>b</sup> For flanges type 21 the outside hub diameter approximately corresponds to the outside pipe diameter.

**Table J-2 — Dimensions of PN 40 flanges,  
symbols see Figure 10**

Dimensions in millimetres

DN	Mating dimensions <sup>a</sup>				
	Outside diameter <i>D</i>	Diameter of bolt circle <i>K</i>	Diameter of bolt hole <i>L</i>	Bolting	
				Number	Size
Flange type					
01, 02, 04, 05, 11, 12, 13, 21					
700	995	900	48	24	M45
800	1 140	1 030	56	24	M52
900	1 250	1 140	56	28	M52
1 000	1 360	1 250	56	28	M52
1 200	1 575	1 460	62	32	M56
1 400	1 795	1 680	62	36	M56
1 600	2 025	1 900	70	40	M64

<sup>a</sup> Further dimensions to be specified by the purchaser.

Table J-3 — Dimensions of PN 63 flanges,  
symbols see Figure 11

Dimensions in millimetres

DN	Mating dimensions <sup>a</sup>				
	Outside diameter <i>D</i>	Diameter of bolt circle <i>K</i>	Diameter of bolt hole <i>L</i>	Bolting	
				Number	Size
	Flange type				
01, 05, 11, 12, 13, 21					
500	800	705	48	20	M45
600	930	820	56	20	M52
700	1 045	935	56	24	M52
800	1 165	1 050	62	24	M56
900	1 285	1 170	62	28	M56
1 000	1 415	1 290	70	28	M64
1 200	1 665	1 530	78	32	M72x6

<sup>a</sup> Further dimensions to be specified by the purchaser.

Table J-4 — Dimensions of PN 100 flanges,  
symbols see Figure 12

Dimensions in millimetres

DN	Mating dimensions <sup>a</sup>					Outside diameter of neck <i>A</i>	Bore diameter <i>B<sub>1</sub></i>
	Outside diameter <i>D</i>	Diameter of bolt circle <i>K</i>	Diameter of bolt hole <i>L</i>	Bolting			
				Number	Size		
	Flange type						
01, 05, 11, 12, 13, 21					11 21 <sup>b</sup>	01 12	
400	715	620	48	16	M45	406,4	411,0
500	870	760	56	20	M52	508,0	513,5

<sup>a</sup> Further dimensions to be specified by the purchaser.

<sup>b</sup> For flanges type 21 the outside hub diameter approximately corresponds to the outside pipe diameter.

## Annex ZA (normative)

### Relationship between this European Standard and the Essential Requirements of Directive 97/23/EC

This European Standard has been prepared under a mandate given to CEN by the European Commission to provide a means of conforming to Essential Requirements of the New Approach Directive 97/23/EC.

Once this standard is cited in the Official Journal of the European Communities under that Directive and has been implemented as a national standard in at least one Member State, compliance with the clauses of this standard given in Table ZA.1 confers, within the limits of the scope of this standard, a presumption of conformity with the corresponding Essential Requirements of that Directive and associated EFTA regulations.

**Table ZA.1 — Correspondence between this European Standard and Directive 97/23/EC**

Clause(s)/ subclause(s) of this EN	Essential Requirements (ER's) of Directive 97/23/EC		Qualifying remarks/ notes
			—
5.1.1 and F.1.1	Annex 1, Clause 4.1a)	Materials for pressurized parts to have appropriate properties for all operating and test conditions: <ul style="list-style-type: none"> <li>— to be sufficiently ductile and tough;</li> <li>— characteristics of material to comply with ESR's at 7.5</li> <li>— to be selected in order to prevent brittle-type fracture, or appropriate measures to be taken.</li> </ul>	—
			—
	Annex 1, Clause 2.1	To be designed to ensure safety throughout intended life <ul style="list-style-type: none"> <li>— to incorporate appropriate safety coefficients.</li> </ul>	—
	Annex 1, Clause 2.2	To be designed for adequate strength.	—
Annex E	Annex 1, Clause 2.2.1	To be designed for loadings appropriate to its intended use.	
	Annex 1, Clause 2.2.2	To be designed for appropriate strength based on a calculation method.	—
	Annex 1, Clause 2.2.3(a)	Requirements to be met by applying one of the following methods <ul style="list-style-type: none"> <li>— design by formula.</li> </ul>	—
	Annex 1, Clause 2.2.3(b)	Design calculations to establish the resistance of equipment, in particular <ul style="list-style-type: none"> <li>— account to be taken of combinations of temperature &amp; pressure;</li> <li>— maximum stresses &amp; peak stresses to be within safe limits.</li> </ul>	—



Table ZA (continued)

Clause(s)/ subclause(s) of this EN	Essential Requirements (ER's) of Directive 97/23/EC		Qualifying remarks/ notes
Annex E and Annex F, Table F.2.5-1			—
	Annex 1, Clause 7.1.2	Permissible general membrane stresses for internal pressure, for predominantly static loads and for temperatures outside the creep range not exceed the smaller of the following values, according to the material used;	—
5.13	Annex 1, Clause 3.1.5	Traceability Materials making up component parts to be identified by suitable means from receipt, through production, up to final test.	—

**WARNING:** Other requirements and other EU Directives may be applicable to the product(s) falling within the scope of this standard.

## Bibliography

- [1] EN 1514-1, *Flanges and their joints — Dimensions of gaskets for PN-designated flanges — Part 1: Non metallic flat gaskets with or without inserts*
- [2] EN 1514-2, *Flanges and their joints — Gaskets for PN-designated flanges — Part 2: Spiral wound gaskets for use with steel flanges*
- [3] EN 1514-3, *Flanges and their joints — Dimensions of gaskets for PN-designated flanges — Part 3: Non-metallic PTFE envelope gaskets*
- [4] EN 1514-4, *Flanges and their joints — Dimensions of gaskets for PN-designated flanges — Part 4: Corrugated, flat or grooved metallic and filled metallic gaskets for use with steel flanges*
- [5] EN 1514-6, *Flanges and their joints — Dimensions of gaskets for PN-designated flanges — Part 6: Covered serrated metal gaskets for use with steel flanges*
- [6] EN 1514-7, *Flanges and their joints — Gaskets for PN-designated flanges — Part 7: Covered metal jacketed gaskets for use with steel flanges*
- [7] EN 1514-8, *Flanges and their joints — Dimensions of gaskets for PN-designated flanges — Part 8: Polymeric O-Ring gaskets for grooved flanges*
- [8] EN 1515-1, *Flanges and their joints — Bolting — Part 1: Selection of bolting*
- [9] EN 1515-2:2001, *Flanges and their joints — Bolting — Part 2: Classification of bolt materials for steel flanges, PN designated*
- [10] EN 1591-2, *Flanges and their joints — Design rules for gasketed circular flange connections — Part 2: Gasket parameters*
- [11] CEN/TS 1591-3, *Flanges and their joints — Design rules for gasketed circular flange connections — Part 3: Calculation method for metal to metal contact type flanged joint*
- [12] EN 10021, *General technical delivery conditions for steel products*
- [13] EN 10025 (all parts), *Hot rolled products of structural steels*
- [14] EN 10216-1:2002, *Seamless steel tubes for pressure purposes — Technical delivery conditions — Part 1: Non-alloy steel tubes with specified room temperature properties*
- [15] EN 10253 (all parts), *Butt-welding pipe fittings*
- [16] EN 12516 (all parts), *Industrial valves — Shell design strength*
- [17] EN 13445 (all parts), *Unfired pressure vessels*
- [18] EN 13458 (all parts), *Cryogenic vessels — Static vacuum insulated vessels*
- [19] EN 13480 (all parts), *Metallic industrial piping*
- [20] EN ISO 3834-2:2005, *Quality requirements for fusion welding of metallic materials — Part 2: Comprehensive quality requirements (ISO 3834-2:2005)*
- [21] EN ISO 4287, *Geometrical product specifications (GPS) — Surface texture: Profile method — Terms, definitions and surface texture parameters (ISO 4287:1997)*
- [22] EN ISO 15607:2003, *Specification and qualification of welding procedures for metallic materials — General rules (ISO 15607:2003)*

- [23] CEN ISO/TR 15608:2005, *Welding — Guidelines for a metallic materials grouping system (ISO/TR 15608:2005)*
- [24] ISO 4200, *Plain end steel tubes, welded and seamless — General tables dimensions and masses per unit length*
- [25] DIN 1681<sup>2)</sup>, *Cast steels for general engineering purposes; technical delivery conditions*
- [26] DIN 17102<sup>2)</sup>, *Weldable normalized fine grain structural steels; technical delivery conditions for plate, strip, wide flats, sections and bars*
- [27] DIN 17103<sup>2)</sup>, *Weldable fine grain structural steel forgings; technical delivery conditions*
- [28] DIN 17245<sup>2)</sup>, *Ferritic steel castings with elevated temperature properties; technical delivery conditions*
- [29] VDTÜV — Data Sheets 350 and 399
- [30] AD Merkblatt W10:1987, *Materials for low temperature application — Ferritic materials*
- [31] AD Merkblatt W1:1995, *Hot rolled products in unalloyed and alloyed steels*
- [32] ISO 7005-1, *Metallic flanges — Part 1: Steel flanges*
- [33] EN ISO 9692-1:2004, *Welding and allied processes — Recommendations for joint preparation — Part 1: Manual metal-arc welding, gas-shielded metal-arc welding, gas welding, TIG welding and beam welding of steels (ISO 9692-1:2003)*
- [34] EN 1092-2, *Flanges and their joints — Circular flanges for pipes, valves, fittings and accessories, PN designated — Part 2: Cast iron flanges*
- [35] EN 1092-3, *Flanges and their joints — Circular flanges for pipes, valves, fittings and accessories, PN designated — Part 3: Copper alloy flanges*
- [36] EN 784-3, *Pressure equipment — Part 3: Definition of parties involved*
- [37] EN 10028-1, *Flat products made of steels for pressure purposes — Part 1: General requirements*

---

<sup>2)</sup> Withdrawn.

## National Annex NA (informative) to BS EN 1092-1:2007

## NA.1 Introduction

In BS EN 1092-1:2007, the materials and material groups used in the manufacture of flanges are given in Table 9 and the Pressure/Temperature ratings of those materials and material groups are given in Annex G (normative).

Additional materials that are widely used in Europe but not listed, either as individual materials or as material groups, in Table 9, or in other EN standards, are given in Annex D (informative). The Pressure/Temperature ratings in Annex G only cover the materials and material groups listed in Table 9. As a result, EN 1092-1:2007 does not include any Pressure/Temperature information for the additional materials given in Table D.1.

In the UK, the predominant materials used in the manufacture of flanges are S235JR/1.0038 (Group 1E1 in Table D.1) and ASME SA 105 (second entry for Group 3E0 in Table D.1). As a consequence, Pressure/Temperature rating information for these two materials is of particular importance for flange manufacturers in the UK.

In order to provide some guidance for UK manufacturers, some analysis has been performed for materials S235JR/1.0038 and ASME SA 105 and the results are given in Table NA.1.

## NA.2 Pressure/Temperature ratings for materials S235JR/1.0038 and ASME SA 105

The values in Table NA.1 have been calculated using the design stresses inferred from Table 19 (for ASME SA 105) and Table F.1 (for S235JR/1.0038) of BS EN 1092-1:2001.

Table NA.1 — Pressure/Temperature (p/T) Ratings<sup>b</sup> for Flanges made of ferritic steels

PN	Material	RT <sup>a</sup>	Maximum Allowable Temperature °C									
			100	150	200	250	300	350	375	400	425	450
			Maximum Allowable Pressure Bar									
2,5	S235JR/1.0038	2,5	2,1	2,0	1,8	1,6	1,3	—	—	—	—	—
	ASME SA 105	2,5	2,5	2,5	2,5	2,4	2,2	2,1	2,0	1,8	1,4	—
6	S235JR/1.0038	6	5,1	4,8	4,3	3,8	3,3	—	—	—	—	—
	ASME SA 105	6	6,0	6,0	6,0	5,7	5,3	5,1	5,0	4,3	3,5	—
10	S235JR/1.0038	10	8,5	8,0	7,3	6,4	5,5	—	—	—	—	—
	ASME SA 105	10	10,0	10,0	10,0	9,6	8,9	8,5	8,3	7,2	5,9	—
16	S235JR/1.0038	16	13,7	12,7	11,7	10,3	8,8	—	—	—	—	—
	ASME SA 105	16	16,0	16,0	16,0	15,4	14,3	13,6	13,3	11,5	9,5	—
25	S235JR/1.0038	25	21,4	20,0	18,4	16,1	13,9	—	—	—	—	—
	ASME SA 105	25	25,0	25,0	25,0	24,1	22,4	21,3	20,8	18,0	14,9	—
40	S235JR/1.0038	40	34,2	32,0	29,5	25,9	22,2	—	—	—	—	—
	ASME SA 105	40	40,0	40,0	40,0	38,6	35,8	34,2	33,3	28,9	23,9	—
63	S235JR/1.0038	63	54,0	50,3	46,5	40,8	35,1	—	—	—	—	—
	ASME SA 105	63	63,0	63,0	63,0	60,8	56,4	53,8	52,5	45,5	37,7	—
100	S235JR/1.0038	100	85,7	80,0	73,8	64,7	55,7	—	—	—	—	—
	ASME SA 105	100	100,0	100,0	100,0	96,5	89,6	85,5	83,3	72,3	59,9	—

<sup>a</sup> -10 °C to +50 °C

<sup>b</sup> The p/T ratings apply only to flange types 06,11,12,13 and 21 having nominal sizes up to and including DN 600.

## BSI — British Standards Institution

BSI is the independent national body responsible for preparing British Standards. It presents the UK view on standards in Europe and at the international level. It is incorporated by Royal Charter.

### Revisions

British Standards are updated by amendment or revision. Users of British Standards should make sure that they possess the latest amendments or editions.

It is the constant aim of BSI to improve the quality of our products and services. We would be grateful if anyone finding an inaccuracy or ambiguity while using this British Standard would inform the Secretary of the technical committee responsible, the identity of which can be found on the inside front cover. Tel: +44 (0)20 8996 9000. Fax: +44 (0)20 8996 7400.

BSI offers members an individual updating service called PLUS which ensures that subscribers automatically receive the latest editions of standards.

### Buying standards

Orders for all BSI, international and foreign standards publications should be addressed to Customer Services. Tel: +44 (0)20 8996 9001. Fax: +44 (0)20 8996 7001. Email: [orders@bsi-global.com](mailto:orders@bsi-global.com). Standards are also available from the BSI website at <http://www.bsi-global.com>.

In response to orders for international standards, it is BSI policy to supply the BSI implementation of those that have been published as British Standards, unless otherwise requested.

### Information on standards

BSI provides a wide range of information on national, European and international standards through its Library and its Technical Help to Exporters Service. Various BSI electronic information services are also available which give details on all its products and services. Contact the Information Centre. Tel: +44 (0)20 8996 7111. Fax: +44 (0)20 8996 7048. Email: [info@bsi-global.com](mailto:info@bsi-global.com).

Subscribing members of BSI are kept up to date with standards developments and receive substantial discounts on the purchase price of standards. For details of these and other benefits contact Membership Administration. Tel: +44 (0)20 8996 7002. Fax: +44 (0)20 8996 7001. Email: [membership@bsi-global.com](mailto:membership@bsi-global.com).

Information regarding online access to British Standards via British Standards Online can be found at <http://www.bsi-global.com/bsonline>.

Further information about BSI is available on the BSI website at <http://www.bsi-global.com>.

### Copyright

Copyright subsists in all BSI publications. BSI also holds the copyright, in the UK, of the publications of the international standardization bodies. Except as permitted under the Copyright, Designs and Patents Act 1988 no extract may be reproduced, stored in a retrieval system or transmitted in any form or by any means – electronic, photocopying, recording or otherwise – without prior written permission from BSI.

This does not preclude the free use, in the course of implementing the standard, of necessary details such as symbols, and size, type or grade designations. If these details are to be used for any other purpose than implementation then the prior written permission of BSI must be obtained.

Details and advice can be obtained from the Copyright & Licensing Manager. Tel: +44 (0)20 8996 7070. Fax: +44 (0)20 8996 7553. Email: [copyright@bsi-global.com](mailto:copyright@bsi-global.com).